

TP-103-13
June 26, 1996

**U.S. DEPARTMENT OF TRANSPORTATION
NATIONAL HIGHWAY TRAFFIC SAFETY ADMINISTRATION**

LABORATORY TEST PROCEDURE

FOR

FMVSS 103

Windshield Defrosting and Defogging Systems



**SAFETY ASSURANCE
Office of Vehicle Safety Compliance
Room 6115, NSA-30
400 Seventh Street, SW
Washington, DC 20590**

**OVSC LABORATORY TEST PROCEDURE NO. 103
TABLE OF CONTENTS**

	PAGE
1. PURPOSE AND APPLICATION	1
2. GENERAL REQUIREMENTS	2
3. SECURITY	3
4. GOOD HOUSEKEEPING	3
5. TEST SCHEDULING AND MONITORING.....	3
6. TEST DATA DISPOSITION	3
7. GOVERNMENT FURNISHED PROPERTY (GFP).....	4
8. CALIBRATION OF TEST INSTRUMENTATION.....	5
9. SUGGESTED TEST EQUIPMENT	6
10. PHOTOGRAPHIC COVERAGE.....	7
11. PRETEST REQUIREMENTS.....	8
12. COMPLIANCE TEST EXECUTION	9
13. POST TEST REQUIREMENTS	17
14. REPORTS.....	18
14.1 VEHICLE MONTHLY STATUS REPORTS	18
14.2 APPARENT NONCOMPLIANCE	18
14.3 FINAL TEST REPORTS.....	18
14.3.1 COPIES REQUIRED	18
14.3.2 REQUIREMENTS	19
14.3.3 FIRST THREE PAGES OF FINAL REPORT	19
14.3.4 TABLE OF CONTENTS	25
15. DATA SHEETS	26
16. FORMS	28

1. PURPOSE AND APPLICATION

The Office of Vehicle Safety Compliance (OVSC) provides contracted laboratories with Laboratory Test Procedures (TPs) which serve as guidelines for obtaining compliance test data. The data are used to determine if a specific vehicle or item of motor vehicle equipment meets the minimum performance requirements of the subject Federal Motor Vehicle Safety Standard (FMVSS). The purpose of the TP is to present a uniform testing and data recording format, and provide suggestions for the use of specific equipment and procedures. Any contractor interpreting any part of a TP to be in conflict with a FMVSS or observing any deficiencies in a TP is required to advise the Contracting Officer's Technical Representative (COTR) and resolve the discrepancy prior to the start of compliance testing.

The TPs are not intended to limit or restrain a contractor from developing or utilizing any testing techniques or equipment, which will assist in procuring the required compliance test data. Contractors must develop detailed in-house working procedures applicable to their specific use.

NOTE: The TPs, prepared for use by independent laboratories under contract to conduct compliance tests for the OVSC, are not intended to limit the requirements of the applicable FMVSS(s). In some cases, the TPs do not include all of the various FMVSS minimum performance requirements. Sometimes, recognizing applicable test tolerances, the TPs specify test conditions, which are less severe than the minimum requirements of the standards themselves. Therefore, compliance of a vehicle or item of motor vehicle equipment is not necessarily guaranteed if the manufacturer limits certification tests to those described in the TPs.

2. GENERAL REQUIREMENTS

FMVSS 103 specifies requirements for windshield defrosting and defogging systems, and the standard applies to passenger cars, multipurpose passenger vehicles, trucks, and buses. Each vehicle shall have a windshield defrosting and defogging system. However, the test procedure only applies to passenger cars.

Passenger car system requirements of FMVSS 103 refer to SAE Recommended Practice J902 dated August 1964, except that the designated windshield areas "A" and "C" are established in accordance with FMVSS 104.

The system shall be tested in accordance with applicable portions of SAE J902, dated August 1964, or SAE J902A, dated March 1967, except that —

- A. During the first 5 minutes of the test, the engine speed or speeds may be those, which the manufacturer recommends as the warm-up procedure for cold weather starting.
- B. During the last 35 minutes of the test period (or the entire test period if the 5 minute warm-up procedure is not used), either —
 - (1) The engine speed shall not exceed 1,500 rpm in neutral gear, or
 - (2) The engine speed and load shall not exceed the speed and load at 25 mph in the manufacturer's recommended gear with road load.
- C. A room air change of 90 times per hour is not required.
- D. The windshield wipers may be used during the test if they are operated without manual assist.
- E. One or two windows may be open a total of one inch.
- F. The defroster blower may be turned on at any time.
- G. The wind velocity is at any level from 0 to 2 mph.
- H. The test chamber temperature and the wind velocity shall be measured, after the engine has been started, at the forward most point of the vehicle or a point 36 inches from the base of the windshield, whichever is farther forward, at a level halfway between the top and bottom of the windshield on the vehicle centerline.

NOTE: Appropriate air temperatures will be substituted for engine coolant temperatures, if air-cooled engines are tested.

3. SECURITY

The contractor shall provide appropriate security measures to protect the OVSC test vehicles from unauthorized personnel during the entire compliance-testing program. The contractor is financially responsible for any acts of theft and/or vandalism, which occur during the storage of test vehicles. Any security problems, which arise, shall be reported by telephone to the Industrial Property Manager (IPM), Office of Contracts and Procurement, within two working days after the incident. A letter containing specific details of the security problem will be sent to the IPM (with copy to the COTR) within 48 hours after the telephone report. The contractor shall protect and segregate the data that evolves from compliance testing before and after each vehicle test. No information concerning the vehicle safety compliance-testing program shall be released to anyone except the COTR, unless specifically authorized by the COTR or the COTR's Branch or Division Chief. **NO INDIVIDUALS, OTHER THAN CONTRACTOR PERSONNEL DIRECTLY INVOLVED IN THE COMPLIANCE TESTING PROGRAM, SHALL BE ALLOWED TO WITNESS ANY VEHICLE COMPLIANCE TEST UNLESS SPECIFICALLY AUTHORIZED BY THE COTR.**

4. GOOD HOUSEKEEPING

Contractors shall maintain the entire vehicle compliance testing area, test fixtures and instrumentation in a neat, clean and painted condition with test instruments arranged in an orderly manner consistent with good test laboratory housekeeping practices.

5. TEST SCHEDULING AND MONITORING

The contractor shall submit a vehicle test schedule to the COTR prior to conducting the first compliance test. Tests shall be completed as required. Scheduling of vehicle tests shall be adjusted to permit vehicles to be tested to other FMVSSs as may be required by the OVSC. All vehicle compliance testing shall be coordinated with the COTR in order to allow monitoring by the COTR and/or other OVSC personnel if desired.

6. TEST DATA DISPOSITION

The contractor shall make all vehicle preliminary compliance test data available to the COTR at the test site within four hours after the test. Final test data, including digital printouts and computer generated plots (if applicable), shall be furnished to the COTR within five working days. Additionally, the contractor shall analyze the preliminary test results as directed by the COTR.

All backup data sheets, strip charts, recordings, plots, technician's notes, etc., shall be either retained, sent to the COTR or destroyed at the conclusion of each delivery order, purchase order, etc.

7. GOVERNMENT FURNISHED PROPERTY (GFP)

ACCEPTANCE OF VEHICLE

The Contractor has the responsibility of accepting the test vehicle from either a new car dealer or a vehicle transporter. In both instances, the contractor acts in the OVSC's behalf when signing an acceptance of the test vehicle. If the vehicle is delivered by a dealer, the contractor must check to verify the following:

- A. All options listed on the "window sticker" are present on the test vehicle.
- B. Tires and wheel rims are new and the same as listed.
- C. There are no dents or other interior or exterior flaws.
- D. The vehicle has been properly prepared and is in running condition.
- E. The glove box contains an owner's manual, warranty document, consumer information, and extra set of keys.
- F. Proper fuel filler cap is supplied on the test vehicle.

If the test vehicle is delivered by a government-contracted transporter, the contractor should check for damage, which may have occurred during transit.

A "Vehicle Condition" form will be supplied to the contractor by the COTR when the test vehicle is transferred from the new car dealer or between test contracts. The upper half of the form describes the vehicle in detail, and the lower half provides space for a detailed description of the post-test condition. Vehicle Condition forms must be returned to the COTR with the copies of the Final Test Report or the reports will NOT be accepted.

NOTIFICATION OF COTR

The COTR must be notified within 24 hours after a test vehicle has been delivered.

8. CALIBRATION OF TEST INSTRUMENTS

Before the contractor initiates the safety compliance test program, a test instrumentation calibration system will be implemented and maintained in accordance with established calibration practices. Guidelines for setting up and maintaining such calibration systems are described in MIL-C-45662A, "Calibration System Requirements". The calibration system shall be set up and maintained as follows:

- A. Standards for calibrating the measuring and test equipment will be stored and used under appropriate environmental conditions to assure their accuracy and stability.
- B. All measuring instruments and standards shall be calibrated by the contractor, or a commercial facility, against a higher order standard at periodic intervals NOT TO EXCEED TWELVE (12) MONTHS! Records, showing the calibration traceability to the National Institute of Standards and Technology (NIST), shall be maintained for all measuring and test equipment.
- C. All measuring and test equipment and measuring standards will be labeled with the following information:
 - (1) Date of calibration
 - (2) Date of next scheduled calibration
 - (3) Name of the technician who calibrated the equipment
- D. A written calibration procedure shall be provided by the contractor, which includes as a minimum the following information for all measurement and test equipment:
 - (1) Type of equipment, manufacturer, model number, etc.
 - (2) Measurement range
 - (3) Accuracy
 - (4) Calibration interval
 - (5) Type of standard used to calibrate the equipment (calibration traceability of the standard must be evident)
- E. Records of calibration for all test instrumentation shall be kept by the contractor in a manner, which assures the maintenance of established calibration schedules. All such records shall be readily available for inspection when requested by the COTR. The calibration procedure must be approved by the COTR before the test program commences.

9. SUGGESTED TEST EQUIPMENT

- A. Engine tachometer, 0 to 2,000 rpm \pm 15 rpm
- B. Thermocouples (or temperature measuring devices) to measure temperatures at 5 or more locations, - 10°F to + 250°F \pm 1°F
- C. Continuous recorder to make permanent supplemental record with the same accuracies as above.
- D. Anemometer, 0 to 20 mph \pm 0.1 mph
- E. Stop watch (or other timing device), \pm 2 seconds in 60 minutes
- F. Throttle control device
- G. Air pressure gage, 0 to 90 psi \pm 1 psi
- H. Spray gun (Binks model 62 with air nozzle 66 and fluid nozzles 66S, 66SF or equivalent)
- I. Distilled water and device for measuring quantity of water used, \pm 0.5 ounces
- J. Device for measuring designated areas of windshield vellum patterns

10. PHOTOGRAPHIC COVERAGE

Photographs shall be black and white, 8 x 10 inches, and properly focused for clear images. A tag, label or placard identifying the test vehicle model, NHTSA number and date shall appear in each photograph and must be legible. Each photograph shall be labeled as to the subject matter.

As a minimum the following photographs shall be included in each **vehicle** final test report:

- A. Left side view of vehicle
- B. Right side view of vehicle
- C. 3/4 frontal view from left side of vehicle
- D. 3/4 rear view from right side of vehicle
- E. Close-up view of vehicle's Certification Label
- F. Close-up view of vehicle's Tire Information Label
- G. Close-up view of defroster control setting on dash including position of inside/outside air control, if applicable
- H. Instrumentation setup
- I. View of windshield fully frosted
- J. Views of windshield at 20, 25 and 40-minute test intervals (or end of test run if sooner) for the longer of the 2 test runs
- K. Views of the windshield vellum patterns showing defrosted areas resulting from both test runs
- L. Any damage or apparent test failure condition that cannot be seen in the above photographs

11. PRETEST REQUIREMENTS

Prior to conducting any compliance tests, contractors are required to submit a detailed in-house compliance test procedure to the COTR, which includes a step-by-step description of the methodology to be used, and a detailed check off list.

The contractor's test procedure shall contain a complete listing of test equipment actually used. The list of test equipment shall include instrument accuracy and calibration due dates. The contractor shall conspicuously identify revisions to its in-house procedures and ensure that obsolete documents are not used.

There shall be no contradiction between the OVSC TP and the contractor's in-house TP. Written approval must be obtained from the COTR before initiating the compliance test program so that all parties are in agreement.

TEST DATA LOSS

A compliance test is not to be conducted unless all of the various test conditions specified in TP103-XX have been met. Failure of a contractor to obtain the required test data and to maintain acceptable limits on test parameters in the manner outlined in TP103-XX may require a retest at the expense of the contractor. The retest costs include all costs associated with conducting the FMVSS 103 retest, and may include the cost of a replacement vehicle (with the same equipment as the original vehicle). If a replacement vehicle is deemed necessary, the original test vehicle used for the invalid test shall remain the property of OVSC, and the retest vehicle shall remain the property of the contractor.

The NHTSA Contracting Officer is the only person authorized to notify the contractor that a retest is required. The retest shall be completed within 2 weeks after receipt of notification by the Contracting Officer that a retest is required. If a retest is conducted, no test report is required for the original test.

12. COMPLIANCE TEST EXECUTION

WINDSHIELD PATTERN PREPARATION

- A. Make 2 patterns of the entire glass area of the windshield from heavy vellum paper. In most cases, a master pattern containing Areas A, C and D will be provided by the COTR.
- B. Measure windshield glass exposed area (to nearest 1 square inch).
NOTE: AMA specification area may be used if it is so noted.

Unless instructed to do so by COTR, do NOT perform items C through G below.

- C. Determine seating H-Point travel.
- D. Determine Seating Reference Point (SRP).
- E. Select the proper Eyellipse pattern for the H-Point travel of this vehicle.
- F. Determine total AREA A and critical AREA C as shown in **Figure 1**.
 - (1) For upper and lower (horizontal) boundaries of desired area:
 - (A) Locate Glazing Surface Reference Line.

TYPICAL LOCATION OF AREAS 'A' AND 'C' AS VIEWED FROM INTERIOR OF VEHICLE

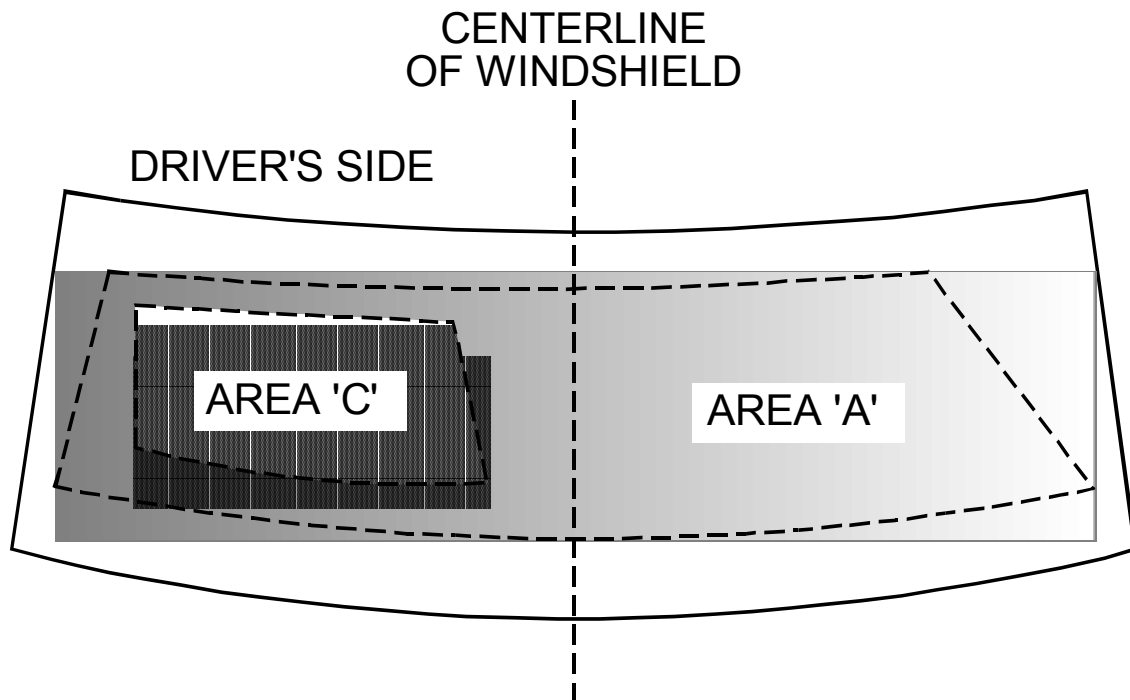

FIGURE 1

12. COMPLIANCE TEST EXECUTION....Continued

- (B) Locate Eyellipse pattern with its major axis along the horizontal Glazing Surface Reference Line and its minor axis along the vertical line from the SRP.
- (C) Determine upper and lower boundaries by constructing planes tangent to the Eyellipse and intersecting the horizontal Glazing Reference Line at the appropriate angles from **Tables 1, 2, 3, and 4**. Where these planes intersect the windshield, make a horizontal boundary on the windshield with wax marking pencil. See **Figure 2**.

SIDE VIEW OF AREA GENERATION

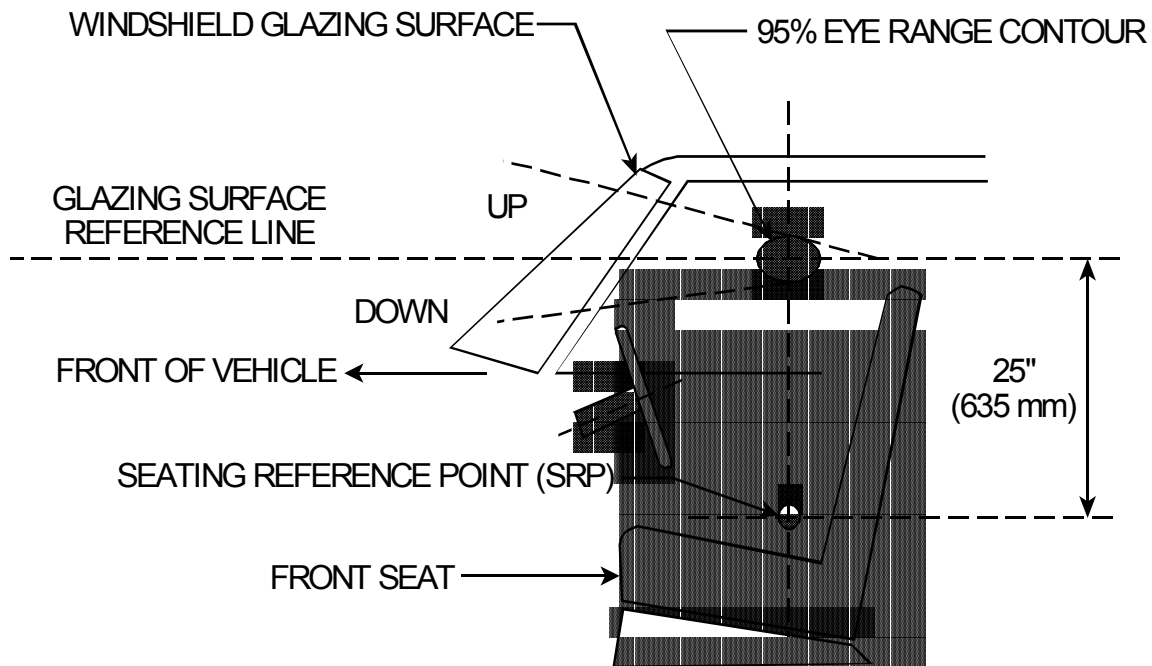

FIGURE 2

(2) For left and right (vertical) boundaries of desired area:

- (A) Locate plan view reference line parallel to the vehicle centerline and outboard of the steering wheel a distance equal to 15 percent of the dimension from steering wheel centerline to the door garnish molding $[0.15(A-B)]$ as shown in **Figures 3 and 4**. These dimensions may be obtained from manufacturers specifications by using SAE Dimensions W3 (shoulder room) and W7 (steering wheel centerline to vehicle centerline).

12. COMPLIANCE TEST EXECUTION...Continued

TABLE 1				
PASSENGER CARS OF LESS THAN 60" IN OVERALL WIDTH				
COLUMN 1	COLUMN 2	COLUMN 3	COLUMN 4	COLUMN 5
ANGLES (degrees)				
AREA	LEFT	RIGHT	UP	DOWN
A (Total)	16	49	7	5
C (Critical)	7	15	3	1

TABLE 2				
PASSENGER CARS OF 60" OR MORE BUT LESS THAN 64" IN OVERALL WIDTH				
COLUMN 1	COLUMN 2	COLUMN 3	COLUMN 4	COLUMN 5
ANGLES (degrees)				
AREA	LEFT	RIGHT	UP	DOWN
A (Total)	17	51	8	5
C (Critical)	7	15	3	1

TABLE 3				
PASSENGER CARS OF 64" OR MORE BUT LESS THAN 68" IN OVERALL WIDTH				
COLUMN 1	COLUMN 2	COLUMN 3	COLUMN 4	COLUMN 5
ANGLES (degrees)				
AREA	LEFT	RIGHT	UP	DOWN
A (Total)	17	53	9	5
C (Critical)	8	15	4	1

TABLE 4				
PASSENGER CARS OF 68" OR MORE IN OVERALL WIDTH				
COLUMN 1	COLUMN 2	COLUMN 3	COLUMN 4	COLUMN 5
ANGLES (degrees)				
AREA	LEFT	RIGHT	UP	DOWN
A (Total)	18	56	10	5
C (Critical)	10	15	5	1

12. COMPLIANCE TEST EXECUTION....Continued

PLAN VIEW OF AREA GENERATION

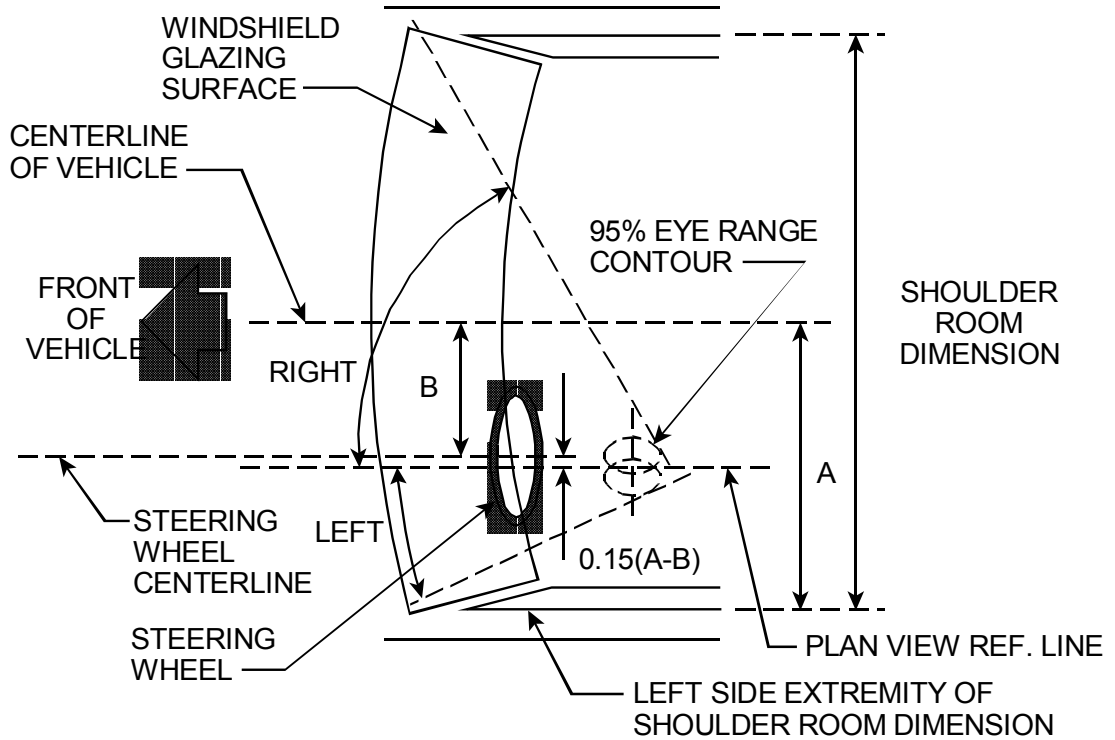

FIGURE 3

PLAN VIEW OF AREA GENERATION

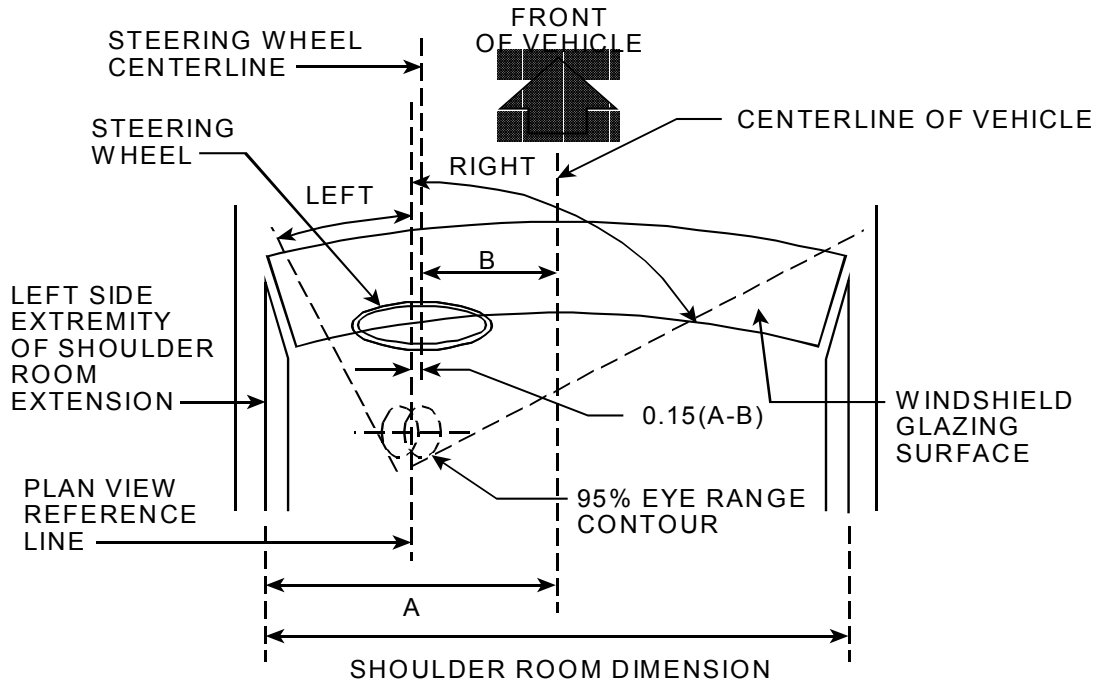

FIGURE 4

12. COMPLIANCE TEST EXECUTION....Continued

Dimensions A and B are shown in **Figures 3 and 4** will then equal $1/2 W3$ and $W7$ respectively.

- (B) Locate "Eyellipse" as shown in **Figures 3 and 4**.
- (C) Determine left and right boundaries by constructing planes tangent to the eyellipse pattern and intersecting the plan view reference line at the appropriate angles from **Tables 1, 2, 3, or 4**. Where these planes intersect the windshield, make a vertical boundary on the windshield with wax marking pencil. See **Figures 3 and 4**.
- G. Place the vellum patterns on the windshield and trace the areas onto each pattern.
- H. Cars for which the windshield pattern for the passenger side critical AREA D (see paragraph 3.2 of SAE Recommended Practice J902 of August 1964) is not furnished by the COTR, determine passenger side critical AREA D by measuring driver critical AREA C and constructing a comparable area on the passenger side.

VEHICLE PREPARATION

- A. Make sure windshield is clean and free of oil, grease, etc. Apply tape to the inside surface of the windshield outlining AREAS A, C and D for effective camera coverage.
- B. Take all precautionary measures that are normally used in northern states, such as immediate access to a battery charger, to ensure cold starting.
- C. Make sure vehicle has sufficient gasoline to complete test schedule that cold weather oil is installed, and proper antifreeze protection has been taken for 0°F operation. The owner's manual shall be consulted to determine if a vehicle change from summer to winter setting is required.
- D. Install thermocouples as follows:
 - (1) Engine coolant at radiator inlet
 - (2) Engine coolant at heater-defroster inlet
 - (3) Left and right defroster outlets at a point that is 1 inch below (upstream of) the plane of the defroster outlet opening.

12. COMPLIANCE TEST EXECUTION....Continued

- (4) Engine lubricant sump (oil pan), if contractor wants to qualify for a shorter cold soak time by this means.
- E. Run engine for at least 5 minutes, then check defroster controls and function of system. Leave controls in positions recommended by the manufacturer for optimum defroster performance. Marking of control positions is recommended for easy recognition of inadvertent movement during or between test runs.
- F. Check for leaks, proper engine coolant level and engine oil level. Correct as necessary.
- G. Position vehicle in cold room, connect instrumentation and check recorders.
- H. Calibrate all instrumentation as required and document for inclusion in the test report. Provide tolerance range indicators on the tracings, charts, data, paper and on instruments so it will be readily apparent that tests were conducted within the requirements of the test procedure.
NOTE: Contractor may connect auxiliary power supply to defroster blower motor or at the input of a motor dropping resistor when applicable, making certain to maintain correct polarity and correct direction of rotation of the blower motor, so as to operate only on the auxiliary power supply with the vehicle electrical input to the blower motor disconnected. The test voltage at the blower motor or the supply end of a motor dropping resistor shall be operated at 115 percent of normal vehicle system voltage (e.g., 13.8 volts on 12 volt system).

TESTING

- A. Prior to the first test run, and if there is a significant temperature deviation between test runs, the cold chamber (with test vehicle inside) shall be pre-conditioned at $0^{\circ}\text{F} \pm 5^{\circ}\text{F}$ for at least 14 hours. Afterward, the test vehicle shall stand inoperative at the specified test temperature with its engine compartment hood raised to soak for a period of not less than 10 hours before each test run. **NOTE:** If instrumentation is available to assure that engine coolant and lubricant are stabilized within the test temperature range for at least 2 hours, a shorter soak time may be used.
- B. During the cold soak period, the chamber air temperature and wind velocity of 0 to 2 mph, directed at the windshield parallel to the longitudinal centerline of the vehicle, shall be measured at a point that is located on the centerline, 1 to 3 feet ahead of the base of the windshield, at a level half way between the top and bottom of the windshield.

12. COMPLIANCE TEST EXECUTION....Continued

- C. At end of soak period, close the engine hood and while maintaining $0^{\circ}\text{F} \pm 5^{\circ}\text{F}$ and wind velocity from 0 mph to 2 mph, spray the entire windshield evenly with 0.010 ounces of water per square inch of glass area. Spraying will be accomplished using the required spray gun and nozzle with 50 psi air pressure at the gun. The nozzle shall be held perpendicular to and 8 to 10 inches away from the windshield surface, stroked back and forth evenly in horizontal overlapping layers, working from top to bottom of one side, the center, and then the opposite side of the windshield in order. This sequence is repeated until all the liquid is applied, taking great care to provide an evenly distributed coating. Wiper blades shall be off the windshield glazing surface during ice application.
- D. With the engine hood closed, continue the vehicle soak for an additional 30 minutes minimum but no more than 40 minutes.
- E. As close to start of test as possible, the observer(s) shall enter the car and check that:
- (1) Defroster controls are in position to divert maximum heated air to the windshield as recommended by the vehicle manufacturer.
 - (2) All windows are closed unless otherwise specified by the vehicle manufacturer (maximum 1 inch total open).
 - (3) Heater intake (if manually operated) is fully OPEN.
 - (4) Windshield wiper is OFF unless specified by the manufacturer.
NOTE: Close-up photographs shall be taken of the defroster control settings at the end of each test run.
- F. Start the engine and bring it as quickly as possible up to 1500 rpm + 100, - 0 rpm in neutral. Verify that electrical system is maintaining 15% over nominal performance (13.8v on a 12v system). **NOTE:** If road load was used by manufacturer and if a dynamometer is not readily available in the cold chamber, test the vehicle involved in neutral, at the engine speed used by the manufacturer during his road load test. If the test results, when tested under these conditions, appear to be a noncompliance to the requirements of FMVSS 103, submit a test report in the normal manner, stating that the test results are not conclusive, since road load could not be used because a dynamometer was not available.
- G. The test chamber temperature and the wind velocity shall be measured, after the engine has been started, at the forward most point of the vehicle or a point 36 inches from the base of the windshield, whichever is farther forward, at a level halfway between the top and bottom of the windshield on the vehicle centerline. **NOTE:** Test conditions are to be maintained constant throughout the duration of the test run. As the test proceeds, the temperature at the chamber air thermocouple location may increase due to the effect of engine heat. However, the temperature shall not exceed + 10°F.

12. COMPLIANCE TEST EXECUTION....Continued

- H. When engine has started and at each 5 minute interval, record instrument readings.
- I. Run the test for 40 minutes from engine start or until AREAS A, C and D are cleared, if sooner, marking defroster area boundaries at each 5-minute interval.
NOTE: Photographs shall be taken of the windshield at the pretest frosted, 20 and 25 minute intervals during the test, and at the end of the test run.

The actual area marked will be that of the DEFROSTED AREA, which is, the area of the windshield composed of dry surface and melted or partially melted (wet) frost, and excluding that area of the windshield covered with dry frost. In other words, the boundary marked will extend to the top of the wet frost line or bottom of the dry frost line. Identify each successive boundary line by its minute interval (i.e., the first will be 5, the second 10, and so on.)

- J. After the test run, the room may be warmed up or engine speed changed if desired to completely clear and dry the windshield.
- K. Place a vellum pattern on the windshield and trace onto it the 5-minute interval boundary lines. Identify vellum as either first or second test run.
- L. Clean the windshield and rerun test to obtain a second vellum pattern.

13. POST TEST REQUIREMENTS

- A. The contractor shall re-verify all instrumentation and checks data sheets and photographs.
- B. For each vellum pattern, make the necessary measurements of percent defrosted area and record with the other required data on the final test report data sheets. Percent area data shall be averaged.
- C. Make clearly readable photographs of the vellum patterns for inclusion in the test report.
- D. Copy applicable pages of the vehicle owner's manual for inclusion in the final test report.
- E. The contractor shall retain all original records in a secure and organized file unless otherwise directed by the COTR.

14. REPORTS

14.1 MONTHLY STATUS REPORTS

The contractor shall submit a monthly Test Status Report and a Vehicle Status Report to the COTR. The Vehicle Status Report shall be submitted until all vehicles or items of equipment are disposed of. Samples of the required Monthly Status Reports are contained in the Report Forms section.

14.2 APPARENT NONCOMPLIANCE

Any indication of a test failure shall be communicated by telephone to the COTR within 24 hours with written notification mailed within 48 hours (Saturdays and Sundays excluded). A Notice of Test Failure (see report forms section) with a copy of the particular compliance test data sheet(s) and preliminary data plot(s) shall be included.

In the event of a test failure, a post test calibration check of some critically sensitive test equipment and instrumentation may be required for verification of accuracy. The necessity for the calibration shall be at the COTR's discretion and shall be performed without additional costs to the OVSC.

14.3 FINAL TEST REPORTS

14.3.1 COPIES

In the case of a test failure, 7 copies of the final test report shall be submitted to the COTR for acceptance within 3 weeks of test completion.

Where there has been no indication of a test failure, 3 copies of each final test report shall be submitted to the COTR within 3 weeks of test completion. Payment of contractor's invoices for completed compliance tests may be withheld until the final test report is accepted by the COTR. Contractors are requested to NOT submit invoices before the COTR is provided copies of the final test report.

Contractors are required to submit the first final test report in draft form within two weeks after the compliance test is conducted. The contractor and the COTR will then be able to discuss the details of both test conduct and report content early in the compliance test program.

Contractors are required to **PROOF READ** all final test reports before submittal to the COTR. The OVSC will not act as a report quality control office for contractors. Reports containing a significant number of errors will be returned to the contractor for correction, and a "hold" will be placed on invoice payment for the particular test.

14. REPORTS....Continued

14.3.2 REQUIREMENTS

The Final Test Report, associated documentation (including photographs) is relied upon as the chronicle of the compliance test. The Final Test Report will be released to the public domain after review and acceptance by the COTR. For these reasons, each final report must be a complete document capable of standing by itself. The contractor should use **detailed** descriptions of all compliance test events. Any events that are not directly associated with the standard but are of technical interest should also be included. The contractor should include as much **detail** as possible in the report. Instructions for the preparation of the first three pages of the final test report are provided below for the purpose of standardization.

14.3.3 FIRST THREE PAGES

A. FRONT COVER

A heavy paperback cover (or transparency) shall be provided for the protection of the final report. The information required on the cover is as follows:

- (1) Final Report Number such as 103-ABC-9X-001 where
 103 is the FMVSS tested
 ABC are the initials for the laboratory
 9X is the Fiscal Year of the test program
 001 is the Group Number (001 for the 1st test)

- (2) Final Report Title And Subtitle such as

COMPLIANCE TESTING FOR FMVSS 103
 Windshield Defrosting and Defogging Systems

World Motors Corporation
 199X XYZ 4-door sedan
 NHTSA No. CX0401

- (3) Contractor's Name and Address such as

COMPLIANCE TESTING LABORATORIES, INC.
 4335 West Dearborn Street
 Detroit, Michigan 48090

NOTE: DOT SYMBOL WILL BE PLACED BETWEEN ITEMS (3) AND (4)

- (4) Date of Final Report completion
- (5) The words "FINAL REPORT"
- (6) The sponsoring agency's name and address as follows

U. S. DEPARTMENT OF TRANSPORTATION
National Highway Traffic Safety Administration
Safety Assurance
Office of Vehicle Safety Compliance
400 Seventh Street, SW
Room 6115 (NSA-30)
Washington, DC 20590

14. REPORTS....Continued

B. FIRST PAGE AFTER FRONT COVER

A disclaimer statement and an acceptance signature block for the COTR shall be provided as follows:

This publication is distributed by the U. S. Department of Transportation, National Highway Traffic Safety Administration, in the interest of information exchange. The opinions, findings and conclusions expressed in this publication are those of the author(s) and not necessarily those of the Department of Transportation or the National Highway Traffic Safety Administration. The United States Government assumes no liability for its contents or use thereof. If trade or manufacturers' names or products are mentioned, it is only because they are considered essential to the object of the publication and should not be construed as an endorsement. The United States Government does not endorse products or manufacturers.

Prepared By: _____

Approved By: _____

Approval Date: _____

FINAL REPORT ACCEPTANCE BY OVSC:

Accepted By: _____

Acceptance Date: _____

14. REPORTS....Continued**C. SECOND PAGE AFTER FRONT COVER**

A completed Technical Report Documentation Page (Form DOT F1700.7) shall be completed for those items that are applicable with the other spaces left blank. Sample data for the applicable block numbers of the title page follows:

Block 1 — REPORT NUMBER

103-ABC-9X-001

Block 2 — GOVERNMENT ACCESSION NUMBER

Leave blank

Block 3 — RECIPIENT'S CATALOG NUMBER

Leave blank

Block 4 — TITLE AND SUBTITLE

Final Report of FMVSS 103 Compliance Testing of 199X World XYZ 4-door sedan, NHTSA No. CX0401

Block 5 — REPORT DATE

March 1, 199X

Block 6 — PERFORMING ORGANIZATION CODE

ABC

Block 7 — AUTHOR(S)

John Smith, Project Manager
Bill Doe, Project Engineer

Block 8 — PERFORMING ORGANIZATION REPORT NUMBER

ABC-DOT-XXX-001

Block 9 — PERFORMING ORGANIZATION NAME AND ADDRESS

ABC Laboratories
405 Main Street
Detroit, MI 48070

Block 10 — WORK UNIT NUMBER

Leave blank

14. REPORTS...Continued**Block 11 — CONTRACT OR GRANT NUMBER**

DTNH22-XX-D-12345

Block 12 — SPONSORING AGENCY NAME AND ADDRESS

US Department of Transportation
National Highway Traffic Safety Administration
Office of Vehicle Safety Compliance
400 Seventh Street, SW, Room 6115
Washington, DC 20590

Block 13 — TYPE OF REPORT AND PERIOD COVERED

Final Test Report
Feb. 15 to Mar. 15, 199X

Block 14 — SPONSORING AGENCY CODE

NSA-30

Block 15 — SUPPLEMENTARY NOTES

Leave blank

Block 16 — ABSTRACT

Compliance tests were conducted on the subject 199X World XYZ 4-door sedan in accordance with the specifications of the Office of Vehicle Safety Compliance Test Procedure No. TP-103-XX for the determination of FMVSS 103 compliance. Test failures identified were as follows:
None

NOTE: Above wording must be shown with appropriate changes made for a particular compliance test. Any questions should be resolved with the COTR.

Block 17 — KEY WORDS

Compliance Testing
Safety Engineering
FMVSS 103

Block 18 — DISTRIBUTION STATEMENT

Copies of this report are available from the following:
NHTSA Technical Reference Division

14. REPORTS....Continued

Room 5108 (NAD-52)
400 Seventh St., SW
Washington, DC 20590
Telephone No.: 202-366-4946

Block 19 — SECURITY CLASSIFICATION OF REPORT

Unclassified

Block 20 — SECURITY CLASSIFICATION OF PAGE

Unclassified

Block 21 — NUMBER OF PAGES

Add appropriate number

Block 22 — PRICE

Leave blank

14.3.4 TABLE OF CONTENTS

Final test report Table of Contents shall include the following:

Section 1 — Purpose of Compliance Test

Section 2 — Test Procedure and Summary of Results

Section 3 — Compliance Test Data

Section 4 — Noncompliance Data (if applicable)

Section 5 — Photographs

Section 6 — Test Equipment List and Calibration Information

Section 7 — Owner's Manual Instructions for use of Defroster
(Applicable pages only)

15. DATA SHEETS

SUMMARY DATA SHEET

FMVSS 103, WINDSHIELD DEFROSTING AND DEFOGGING SYSTEMS

Car Mod Yr/Make/Model/Body Style: _____

Car NHTSA No.: _____ ; VIN: _____ ; Build Date: _____

Test Lab.: _____

Contract No.: DTNH22-_____ ; Delivery Order No.: _____

Windshield Area: _____ in.²; AREA C: _____ in.²; AREA D: _____ in.²; AREA A: _____ in.²

Manufacturer's windshield pattern used: Yes - ___ ; No - _____

Engine Thermostat Nominal Regulating Temperature = _____ °F

Heater-Defroster System Includes Air Conditioner: Yes - ___ ; No - _____

Describe Unusual Features of Defrosting System:

Describe Unusual Features of Test Car:

DESIGNATION	AREA PERCENT DEFROSTED					
	TEST 1	TEST 2	AVG.	REQD.	PASS	FAIL
CRITICAL AREA C AT 20 MINUTES	%	%	%	80% Minimum		
PASSENGER AREA D AT 25 MINUTES	%	%	%	80% Minimum		
TOTAL AREA A AT 40 MINUTES	%	%	%	95% Minimum		

REMARKS:

RECORDED BY: _____ ; DATE: _____

APPROVED BY: _____

15. DATA SHEETS...Continued

FMVSS 103 TEST DATA RECORD -- TEST RUN No. _____

Test Lab.: _____ ; Test Date: _____

Car Mod Yr/Make/Model/Body Style:

NHTSA#: _____; If 1st Test Run, chamber conditioned __ hrs @ 0°±5°F(14 hrs min)

Cold Soak Period: ____ hours at 0°F ± 5°F (10 hrs min. unless Alt. Method used)
 If Alt. Method used, time engine coolant and lubricant stabilized at 0°F: ____ hrs, ____ min

Water Spray Gun and Nozzle Type: _____

Spray Gun Pressure: _____ psi (50 psi ± 3 psi)

Water Used, _____ fluid oz. (0.010 ounces per square inch of windshield area)

Soak Period Between Ice Application and Test Start: _____ minutes (30 to 40 minutes)

Engine Speed: _____ rpm (1500 to 1600 rpm)

Wind at specified location in front of windshield: _____ mph (0 to 2 mph)

Number Of Vehicle Occupants: _____ (2 maximum)

Describe window openings, if any:

TIME FROM START (minutes)	MOTOR VOLTAGE (volts)	TEMPERATURE, °F					DEFROSTED AREA, %		
		TEST ROOM	ENGINE WATER	HEATER WATER IN	DEFROSTER AIR		A	C	D
					DRIVER	PASSENGER			
0		°F	°F	°F	°F	°F	%	%	%
5		°F	°F	°F	°F	°F	%	%	%
10		°F	°F	°F	°F	°F	%	%	%
15		°F	°F	°F	°F	°F	%	%	%
20		°F	°F	°F	°F	°F	%	%	%
25		°F	°F	°F	°F	°F	%	%	%
30		°F	°F	°F	°F	°F	%	%	%
35		°F	°F	°F	°F	°F	%	%	%
40		°F	°F	°F	°F	°F	%	%	%

RECORDED BY: _____ ; DATE: _____

16. FORMS

LABORATORY NOTICE OF TEST FAILURE TO OVSC

FMVSS NO.: 103 ; TEST DATE: _____

LABORATORY: _____

CONTRACT NO.: _____ DELV. ORDER NO.: _____

LABORATORY PROJECT ENGINEER'S NAME: _____

TEST SPECIMEN DESCRIPTION: _____

VEHICLE NHTSA NO.: _____ VIN: _____

MFR: _____

FAILURE DESCRIPTION: _____

FMVSS REQUIREMENT, PARAGRAPH § ____ : _____

NOTIFICATION TO NHTSA (COTR): _____

DATE: _____ BY: _____

REMARKS:

16. FORMS....Continued

MONTHLY TEST STATUS REPORT

FMVSS 103

DATE OF REPORT: _____

No.	VEHICLE NHTSA No., MAKE & MODEL	COMPLIANCE TEST DATE	PASS/ FAIL	DATE REPORT SUBMITTED	DATE INVOICE SUBMITTED	INVOICE PAYMENT DATE
1						
2						
3						
4						
5						
6						
7						
8						
9						
10						
11						
12						
13						
14						
15						
16						
17						
18						
19						
20						

16. REPORT FORMS....Continued

MONTHLY VEHICLE STATUS REPORT

FMVSS 103

DATE OF REPORT: _____

No.	VEHICLE NHTSA No., MAKE & MODEL	DATE OF DELIVERY	TEST COMPLETE DATE	VEHICLE SHIPMENT DATE	CONDITION OF VEHICLE
1					
2					
3					
4					
5					
6					
7					
8					
9					
10					
11					
12					
13					
14					
15					
16					
17					
18					
19					
20					