

TP-210-09
Feb 7, 1994

U.S. DEPARTMENT OF TRANSPORTATION
NATIONAL HIGHWAY TRAFFIC SAFETY ADMINISTRATION

LABORATORY TEST PROCEDURE

FOR

FMVSS 210

Seat Belt Assembly Anchorages



SAFETY ASSURANCE
Office of Vehicle Safety Compliance
Room 6115, NSA-30
400 Seventh Street, SW
Washington, DC 20590

OVSC LABORATORY TEST PROCEDURE NO. 210

TABLE OF CONTENTS

| | PAGE |
|--|-------------|
| 1. PURPOSE AND APPLICATION | 1 |
| 2. GENERAL REQUIREMENTS | 2 |
| 3. SECURITY | 3 |
| 4. GOOD HOUSEKEEPING..... | 3 |
| 5. TEST SCHEDULING AND MONITORING..... | 3 |
| 6. TEST DATA DISPOSITION | 3 |
| 7. GOVERNMENT FURNISHED PROPERTY (GFP)..... | 4 |
| 8. CALIBRATION OF TEST INSTRUMENTS | 7 |
| 9. PHOTOGRAPHIC DOCUMENTATION | 10 |
| 10. DEFINITIONS..... | 11 |
| 11. PRETEST REQUIREMENTS..... | 13 |
| 12. COMPLIANCE TEST EXECUTION | 14 |
| 13. POST TEST REQUIREMENTS | 22 |
| 14. REPORTS | 22 |
| 14.1. MONTHLY STATUS REPORTS | 22 |
| 14.2. APPARENT TEST FAILURE..... | 22 |
| 14.3. FINAL TEST REPORTS..... | 22 |
| 14.3.1. COPIES..... | 22 |
| 14.3.2. REQUIREMENTS | 23 |
| 14.3.3. FIRST THREE PAGES | 23 |
| 14.3.4. TABLE OF CONTENTS..... | 29 |
| 15. DATA SHEETS | 30 |
| 16. FORMS | 39 |
| APPENDIX A, FMVSS 210, Seat Belt Assembly Anchorages | 42 |
| APPENDIX B, SAE J383, Motor Vehicle Seat Belt Anchorages | 51 |

1. PURPOSE AND APPLICATION

The Office of Vehicle Safety Compliance (OVSC) provides contracted laboratories with Laboratory Test Procedures (TPs) which serve as guidelines for obtaining compliance test data. The data are used to determine if a specific vehicle or item of motor vehicle equipment meets the minimum performance requirements of the subject Federal Motor Vehicle Safety Standard (FMVSS). The purpose of the OVSC Laboratory Test Procedures is to present a uniform testing and data recording format, and provide suggestions for the use of specific equipment and procedures. Any contractor interpreting any part of an OVSC Laboratory Test Procedure to be in conflict with a Federal Motor Vehicle Safety Standard or observing any deficiencies in a Laboratory Test Procedure is required to advise the Contracting Officer's Technical Representative (COTR) and resolve the discrepancy prior to the start of compliance testing.

Contractors are required to submit a detailed test procedure to the COTR before initiating the compliance test program. The procedure must include a step-by-step description of the methodology to be used.

The OVSC Laboratory Test Procedures are not intended to limit or restrain a contractor from developing or utilizing any testing techniques or equipment, which will assist in procuring the required compliance test data.

NOTE:

The OVSC Laboratory Test Procedures, prepared for use by independent laboratories under contract to conduct compliance tests for the OVSC, are not intended to limit the requirements of the applicable FMVSS(s). In some cases, the OVSC Laboratory Test Procedures do not include all of the various FMVSS minimum performance requirements. Sometimes, recognizing applicable test tolerances, the Test Procedures specify test conditions, which are less severe than the minimum requirements of the standards themselves. Therefore, compliance of a vehicle or item of motor vehicle equipment is not necessarily guaranteed if the manufacturer limits certification tests to those described in the OVSC Laboratory Test Procedures.

2. GENERAL REQUIREMENTS

FMVSS 210 establishes requirements for seat belt assembly anchorages to insure their proper location for effective occupant restraint and to reduce the likelihood of their failure. The standard applies to passenger cars, multipurpose passenger vehicles (MPVs), trucks and buses.

Seat belt anchorages for a Type 2 seat belt assembly (combination lap and shoulder belts) shall be installed for each forward-facing outboard designated seating position (DSP) in passenger cars and for each DSP for which a Type 2 seat belt assembly is required by FMVSS 208 in vehicles other than passenger cars.

Seat belt anchorages for a Type 1 (lap belt) or a Type 2 seat belt assembly shall be installed for each DSP, except a passenger seat in a bus.

Each vehicle that is equipped with an automatic restraint at the front right outboard DSP that cannot be used for securing a child restraint system or cannot be adjusted by the vehicle owner to secure a child restraint system solely through the use of attachment hardware installed as an item of original equipment by the vehicle manufacturer shall have, at the manufacturer's option, either anchorages for a Type 1 or lap belt assembly at that position or a Type 1 or Type 2 seat belt assembly at that position.

Except for side-facing seats, the anchorage, attachment hardware, and attachment bolts for a Type 1 seat belt assembly or the pelvic portion of a Type 2 seat belt assembly, if voluntarily installed, or the pelvic portion of a Type 2 seat belt assembly or automatic seat belt assembly, if equipped with a detachable upper torso belt, shall withstand a 5,000 pound force. The anchorage, attachment hardware, and attachment bolts for a Type 2 or automatic seat belt assembly, installed to comply with FMVSS 208, shall withstand 3,000-pound forces. The attachment hardware of a seat belt assembly subjected to S5.1 or FMVSS 208 other than due to FMVSS 208, S4.1.2.1(c)(2) does not have to meet these requirements. Permanent deformation or rupture of a seat belt anchorage or its surrounding area is not considered to be a failure, if the required force is sustained for the specified time. Designated seating positions (DSPs) common to the same occupant seat and that face in the same direction or for laterally adjacent seating positions not common to the same occupant seat that face in the same direction, if the vertical centerline of the bolt hole for at least one of those DSPs is within 12 inches of the vertical centerline of assemblies attached to those anchorages of another DSP shall be tested by simultaneously loading the seat belt.

3. SECURITY

The contractor shall provide appropriate security measures to protect the OVSC test vehicles from unauthorized personnel during the entire compliance-testing program. The contractor is financially responsible for any acts of theft and/or vandalism, which occur during the storage of test vehicles. Any security problems, which arise, shall be reported by telephone to the Industrial Property Manager (IPM), Office of Contracts and Procurement, within two working days after the incident. A letter containing specific details of the security problem will be sent to the IPM (with copy to the COTR) within 48 hours.

The contractor shall protect and segregate the data that evolves from compliance testing before and after each vehicle test. No information concerning the vehicle safety compliance-testing program shall be released to anyone except the COTR, unless specifically authorized by the COTR or the COTR's Branch Chief or Division Chief.

NO INDIVIDUALS, OTHER THAN CONTRACTOR PERSONNEL DIRECTLY INVOLVED IN THE COMPLIANCE TESTING PROGRAM, SHALL BE ALLOWED TO WITNESS ANY VEHICLE COMPLIANCE TEST UNLESS SPECIFICALLY AUTHORIZED BY THE COTR.

4. GOOD HOUSEKEEPING

Contractors shall maintain the entire vehicle compliance testing area, test fixtures and instrumentation in a neat, clean and painted condition with test instruments arranged in an orderly manner consistent with good test laboratory housekeeping practices.

5. TEST SCHEDULING AND MONITORING

The contractor shall submit a vehicle test schedule to the COTR prior to conducting the first compliance test. Tests shall be completed as required in the contract. Scheduling shall be adjusted to permit vehicles to be tested to other FMVSSs as may be required by the OVSC. All compliance testing shall be coordinated with the COTR in order to allow monitoring by the COTR or other OVSC personnel.

6. TEST DATA DISPOSITION

The contractor shall make all preliminary compliance test data available to OVSC within four hours after the test, if requested. Final test data, including digital printouts and computer generated plots (if applicable), shall be furnished to the COTR within 5 working days. Additionally, the contractor shall analyze the preliminary test results as directed by the COTR.

All backup data sheets, strip charts, recordings, plots, technician's notes etc., shall be either sent to the COTR or destroyed at the conclusion of each delivery order, purchase order, etc. Calibration information shall not be destroyed.

7. GOVERNMENT FURNISHED PROPERTY (GFP)

ACCEPTANCE OF VEHICLE

The Contractor has the responsibility of accepting the test vehicle from either a new car dealer or a vehicle transporter. In both instances, the contractor acts in the OVSC's behalf when signing an acceptance of the test vehicle. If the vehicle is delivered by a dealer, the engineer must check to verify the following:

- A. All options listed on the "window sticker" are present on the test vehicle.
- B. Tires and wheel rims are new and the same as listed.
- C. There are no dents or other interior or exterior flaws.
- D. The vehicle has been properly prepared and is in running condition.
- E. The glove box contains an owner's manual, warranty document, consumer information, and extra set of keys.
- F. Proper fuel filler cap is supplied on the test vehicle.

If the test vehicle is delivered by a government-contracted transporter, the contractor's test engineer shall check for damage, which may have occurred during transit.

A "Report Of Vehicle Condition At The Completion Of Testing" form (shown on the next page) will be supplied to the contractor by the COTR when the test vehicle is transferred from the new car dealer or between test contracts. The upper half of the form describes the vehicle in detail, and the lower half provides space for a detailed description of the posttest condition. This form must be returned to the COTR with the copies of the Final Test Report or the reports will NOT be accepted.

NOTIFICATION OF COTR

The COTR must be notified within 24 hours after a test vehicle has been delivered.

REPORT OF VEHICLE CONDITION AT THE COMPLETION OF TESTING

CONTRACT NO.: DTNH22-_____ DATE: _____

FROM: _____

TO: _____

The following vehicle has been subjected to compliance testing for FMVSS No. _____

The vehicle was inspected upon arrival at the laboratory for the test and found to contain all of the equipment listed below. All variances have been reported within 2 working days of vehicle arrival, by letter, to the NHTSA Industrial Property Manager (NAD-30), with a copy to the OVSC COTR. The vehicle is again inspected, after the above test has been conducted, and all changes are noted below. The final condition of the vehicle is also noted in detail.

MODEL YEAR/MAKE/MODEL/BODY STYLE: _____

NHTSA NO.: _____ BODY COLOR: _____ VIN: _____

ODOMETER READINGS: ARRIVAL - _____ miles DATE - _____

COMPLETION - _____ miles DATE - _____

PURCHASE PRICE: \$ _____ DEALER'S NAME: _____

ENGINE DATA: _____ Cylinders _____ Liters _____ Cubic Inches

TRANSMISSION DATA: _____ Automatic _____ Manual _____ No. of Speeds

FINAL DRIVE DATA: _____ Rear Drive _____ Front Drive _____ 4 Wheel Drive

TIRE DATA: Size - _____ Mfr. - _____

CHECK APPROPRIATE BOXES FOR VEHICLE EQUIPMENT:

| | | | | | |
|--------------------------|-----------------------|--------------------------|-----------------------|--------------------------|-------------------|
| <input type="checkbox"/> | Air Conditioning | <input type="checkbox"/> | Traction Control | <input type="checkbox"/> | Clock |
| <input type="checkbox"/> | Tinted Glass | <input type="checkbox"/> | All Wheel Drive | <input type="checkbox"/> | Roof Rack |
| <input type="checkbox"/> | Power Steering | <input type="checkbox"/> | Speed Control | <input type="checkbox"/> | Console |
| <input type="checkbox"/> | Power Windows | <input type="checkbox"/> | Rear Window Defroster | <input type="checkbox"/> | Driver Air Bag |
| <input type="checkbox"/> | Power Door Locks | <input type="checkbox"/> | Sun Roof or T-Top | <input type="checkbox"/> | Passenger Air Bag |
| <input type="checkbox"/> | Power Seat(s) | <input type="checkbox"/> | Tachometer | <input type="checkbox"/> | Front Disc Brakes |
| <input type="checkbox"/> | Power Brakes | <input type="checkbox"/> | Tilt Steering Wheel | <input type="checkbox"/> | Rear Disc Brakes |
| <input type="checkbox"/> | Antilock Brake System | <input type="checkbox"/> | AM/FM/Cassette Radio | <input type="checkbox"/> | Other- |

LIST OTHER PERTINENT OPTIONAL EQUIPMENT ON NEXT PAGE (REMARKS SECTION)

REPORT OF VEHICLE CONDITION AT THE COMPLETION OF TESTING....Continued

REMARKS:

Equipment that is no longer on the test vehicle as noted on previous page:

Explanation for equipment removal:

Test Vehicle Condition:

RECORDED BY: _____

DATE: _____

APPROVED BY: _____

8. CALIBRATION OF TEST INSTRUMENTS

Before the contractor initiates the safety compliance test program, a test instrumentation calibration system shall be implemented and maintained in accordance with established calibration practices. Guidelines for setting up and maintaining such calibration systems are described in MIL-C-45662A, "Calibration System Requirements". The calibration system shall be set up and maintained as follows:

- A. Standards for calibrating the measuring and test equipment will be stored and used under appropriate environmental conditions to assure their accuracy and stability.
- B. All measuring instruments and standards shall be calibrated by the contractor, or a commercial facility, against a higher order standard at periodic intervals NOT TO EXCEED SIX (6) MONTHS! Records, showing the calibration trace ability to the National Institute of Standards and Technology (NIST), shall be maintained for all measuring and test equipment.
- C. All measuring and test equipment and measuring standards will be labeled with the following information:
 - (1) Date of calibration
 - (2) Date of next scheduled calibration
 - (3) Name of company performing calibration service (if different than contractor)
 - (4) Name and employer of the technician who calibrated the equipment
- D. A written calibration procedure shall be provided by the contractor, which includes as a minimum the following information for all measurement and test equipment:
 - (1) Type of equipment, manufacturer, model number, etc.
 - (2) Measurement range — see next page
 - (3) Accuracy — see next page
 - (4) Calibration interval
 - (5) Type of standard used to calibrate the equipment (calibration trace ability of the standard must be evident)

8. CALIBRATION OF TEST INSTRUMENTS....Continued

TEST EQUIPMENT ACCURACY

| EQUIPMENT | RANGE | ACCURACY |
|---|--|--|
| Hydraulic Rams (5 Reqd) | 0-120% of Specified Load | N/A |
| Load Cells (5 Reqd) | 0-120% of Readout Capability | $\pm 0.5\%$ |
| Strip Chart Recorder | Readout Capability of 3% of Maximum Load | $\pm 1.0\%$ |
| Hydraulic Pump | Approx. 3.8 gpm | N/A |
| DC Power Supply | Adequate for Load Cells Used | Line Reg. of 0.05% (105 to 125 v) Load Reg. of 0.05% (0 to Full) Ripple: 5 mv P/P Stability: 0.1% |
| Digital Voltmeter or Equivalent Used to Monitor Load Cell Outputs | 4 Digit Readout | $\pm 0.1\%$ |
| Signal Conditioning and Calibration Units | Adequate for Load Cells Used | $\pm 0.5\%$ |
| H-Point Machine | N/A | N/A |
| Steel Scale | 36" Minimum | $\pm 0.1"$ |

8. CALIBRATION OF TEST INSTRUMENTS....Continued

- E. Records of calibration for all test instrumentation shall be kept by the contractor in a manner, which assures the maintenance of established calibration schedules. All such records shall be readily available for inspection when requested by the COTR. The calibration system shall need the acceptance of the COTR before the test program commences.
- F. Test equipment will receive a calibration check immediately prior to and after the test. This check will be recorded by the test technician(s) and included in the final report.

NOTE: In the event of a failure to the standard's minimum performance requirements, a posttest calibration check of some critically sensitive test equipment and instrumentation may be required for verification of accuracy. The necessity for the calibration will be at the COTR's discretion and will be performed without additional cost.

9. PHOTOGRAPHIC DOCUMENTATION

Photographs, if required, shall be glossy black and white, 8-1/2 x 11 inches, and properly focused for clear images. A tag, label or placard identifying the test vehicle model, NHTSA number and date or item of equipment part number and date shall appear in each photograph and must be legible. Each photograph shall be labeled as to the subject matter.

As a minimum the following photographs shall be included in each vehicle final test report:

- A. 3/4 frontal right side view
- B. 3/4 rearward left side view
- C. Test vehicle's certification label
- D. Test vehicle's tire information placard or label
- E. 3/4 frontal left side view of test vehicle with test apparatus in place
- F. 3/4 frontal right side view of test vehicle with test apparatus in place
- G. Vehicle tie down at each tie down location
- H. Pretest full front and side views of each seat belt system installed in the vehicle
- I. Pretest equipment set up at each designated seating position
- J. Post test condition of each seat belt assembly anchorage
- K. Load system control and data recording device in test position
- L. Loading device with load cell and body block in test position
NOTE: Not necessary if covered by other photographs
- M. Pretest condition of each seat belt anchorage
- N. Post test condition of each seat belt anchorage
- O. Any condition, which requires special detail

10. DEFINITIONS

ATTACHMENT HARDWARE

Any or all hardware designed for securing the webbing of a seat belt assembly to a motor vehicle.

CURB WEIGHT

Weight of the vehicle as delivered with full capacity of vehicle fluids.

DESIGNATED SEATING POSITION (DSP)

Any plan view location capable of accommodating a person at least as large as a 5th percentile adult female, if the overall seat configuration and design and vehicle design is such that the position is likely to be used as a seating position while the vehicle is in motion, except for auxiliary seating accommodations such as temporary or folding jump seats. The number of DSP's in a vehicle is printed on the tire placard as required by FMVSS 110.

H-POINT

Mechanically hinged hip point of a manikin, which simulates the actual pivot center of the human torso and thigh, described in SAE J826.

H-POINT TEMPLATE

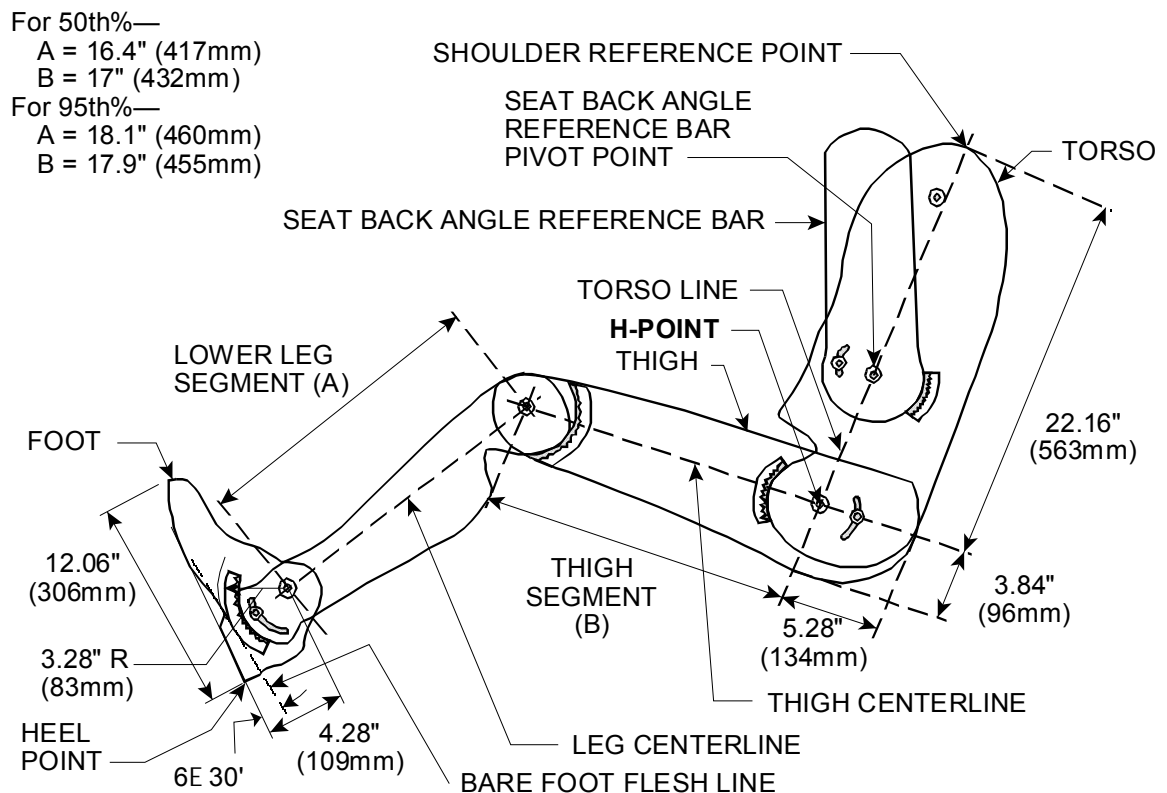

10. DEFINITIONS....Continued

SEAT BELT ASSEMBLY

Any strap, webbing or similar device designed to secure a person in a motor vehicle in order to mitigate the results of any accident, including all necessary buckles and other fasteners, and all hardware designed for installing such seat belt assembly in a motor vehicle.

SEAT BELT ASSEMBLY ANCHORAGE

Any component, other than the webbing or straps involved in transferring seat belt assembly loads to the vehicle structure, including, but not limited to, the attachment hardware, seat frames, seat pedestals, and the vehicle structure itself.

SEATING REFERENCE POINT (SRP)

Manufacturer's Design Reference Point which —

- A. Establishes the rearmost normal design driving or riding position of each DSP in a vehicle
- B. Has coordinates established relative to the designed vehicle structure
- C. Simulates the position of the center pivot of the human torso and thigh
- D. Is the reference point employed to position the two-dimensional templates described in SAE Recommended Practice J826, Manikins for use In Defining Vehicle Seating Accommodation.

SHOULDER REFERENCE POINT (SHRP)

A point 22.16" above the H-Point along the torso centerline of the two-dimensional drafting template described in SAE J383 — IT DOES NOT DESCRIBE A SHOULDER JOINT

TORSO LINE

Line connecting the H-Point and the SHRP as defined in SAE Recommended Practice J383, Motor Vehicle Seat Belt Anchorage.

TYPE 1 SEAT BELT ASSEMBLY

Lap belt assembly for occupants pelvic or lower body restraint.

TYPE 2 SEAT BELT ASSEMBLY

A combination of pelvic (lap belt) and upper torso (shoulder belt) restraints.

11. PRETEST REQUIREMENTS

Prior to conducting any compliance tests, contractors are required to submit a detailed in-house compliance test procedure to the COTR, which includes:

- A. A step-by-step description of the methodology to be used. The in-house test procedure will be written in a check-off sheet format and will describe each significant task the test technician must perform to accomplish the testing. The check-off list test procedure is intended to provide the test technician with a foolproof cookbook plan to conduct the test and produce the necessary data. The test procedure shall be of sufficient detail to guarantee successful testing.
- B. A written quality control (QC) procedure which shall include calibrations, the data review process, report review, and the people assigned to perform QC on each task.
- C. A complete listing of test equipment, which shall include instrument accuracy and calibration, dates.
- D. Detailed check-off lists to be used during the test and during data review.

There shall be no contradiction between the OVSC Laboratory Test Procedure and the contractor's in-house test procedure. The procedures shall cover all aspects of testing from vehicle receipt to submission of the Final Report. Written approval must be obtained from the COTR before initiating the compliance test program so that all parties are in agreement. A compliance test is not to be conducted unless all of the various test conditions specified in the applicable OVSC Laboratory Test Procedure have been met. Failure of a contractor to obtain the required test data and to maintain acceptable limits on test parameters in the manner outlined in the applicable OVSC Laboratory Test Procedure shall require a retest at the expense of the contractor. The retest costs will include the cost of the replacement vehicle and the service costs for conducting the retest.

RECEIVING INSPECTION OF TEST VEHICLES

- A. A clean and secure test vehicle storage area shall be maintained by the contractor. The test vehicle shall be protected from theft of equipment.
- B. Upon receipt of the test vehicle, it shall be identified by the contractor with a NHTSA number previously furnished by the COTR.
- C. The test vehicle's seats and restraint systems shall be subjected to a visual inspection to ascertain that the seat belt assembly anchorage systems are complete and the seats and seat belt assemblies are functional. Any damage that could influence the test results shall be recorded on the Vehicle Condition sheet, and any unusual condition shall be reported to the COTR before initiation of testing. The COTR must approve the testing of any unusual test specimen.

11. PRETEST REQUIREMENTS....Continued

- D. The operation of all adjustable seating systems will be checked to ascertain that the systems operate correctly. The results of this inspection shall be recorded on the Receiving-Inspection sheet.

12. COMPLIANCE TEST EXECUTION

GENERAL STATEMENT OF S210 REQUIREMENTS

FMVSS 210 establishes requirements for Seat Belt Assembly Anchorages. Those requirements are detailed in Title 49 Code of Federal Regulations Part 571.210.

S210 TEST EQUIPMENT DESCRIPTION — The test laboratory is responsible for supplying all of the following equipment.

- A. A test loading, monitoring, and control system which shall consist of a maximum of 7 load cells, with 1 load cell mounted on each body block and where applicable one on each seat (where the seat belt assembly is attached to the seat) measuring the force applied. Force control shall be derived from a closed loop programmable force generator and shall be capable of simultaneously supplying loads to a maximum of 5 separate body blocks and two seats at a constant rate. In addition, if any seat belts or cables (used in lieu of seat belts) fail during the test, the effect on the loading of the remaining anchorages shall not cause those anchorages to exceed the load time, load rate or force requirements of the standard, as the test is completed for those anchorages that did not fail.

Recorded data shall include preload, loading, and unloading of the anchorages at the end of the holding period. The measured force at each body block shall be applied and controlled at a rate less than the maximum rate specified (50,000 pounds per second for Type 1 and 30,000 pounds per second for Type 2) in FMVSS 210. If all loading devices are not connected to the same load source, the application rate difference shall not exceed five percent. The maximum force, maintained for the time interval specified, shall be within -10, -50 pounds of the standard's specified maximum value. The loading apparatus shall be mounted so that it is sturdy enough to adequately withstand the loads applied and so that it will load the anchorages at the required angles.

IT IS IMPORTANT TO NOTE THAT A MAXIMUM OF 7 SEPARATE LOADING DEVICES CAN BE REQUIRED DEPENDENT UPON THE TEST VEHICLE ANCHORAGE CONFIGURATION AND A PLOT OF LOAD VERSUS TIME MUST BE GENERATED DURING THE TEST OR FROM REAL TIME CONTINUOUS MEASUREMENTS RECORDED AND STORED DURING THE TEST.

- B. Three (3) Type A lap belt blocks (or 2 Type A lap belt blocks and 1 Type B lap belt block) and 2 shoulder belt blocks shown in Figures 1, 2 and 3.
- C. Appropriate angle, length, width, height, etc. measuring devices.

12. COMPLIANCE TEST EXECUTION...Continued

- D. Restraining device or fixture to completely tie-down and immobilize the S210 test vehicle when applying the required anchorage loads.
- E. System to raise and hold the test vehicle at least 1" above the floor level.

NOTE: LAP BELT BODY BLOCK WILL BE COVERED BY 1" MEDIUM DENSITY CANVAS COVERED FOAM RUBBER WHERE LAP BELT CONTACTS BODY BLOCK.

TYPE A LAP BELT BODY BLOCK

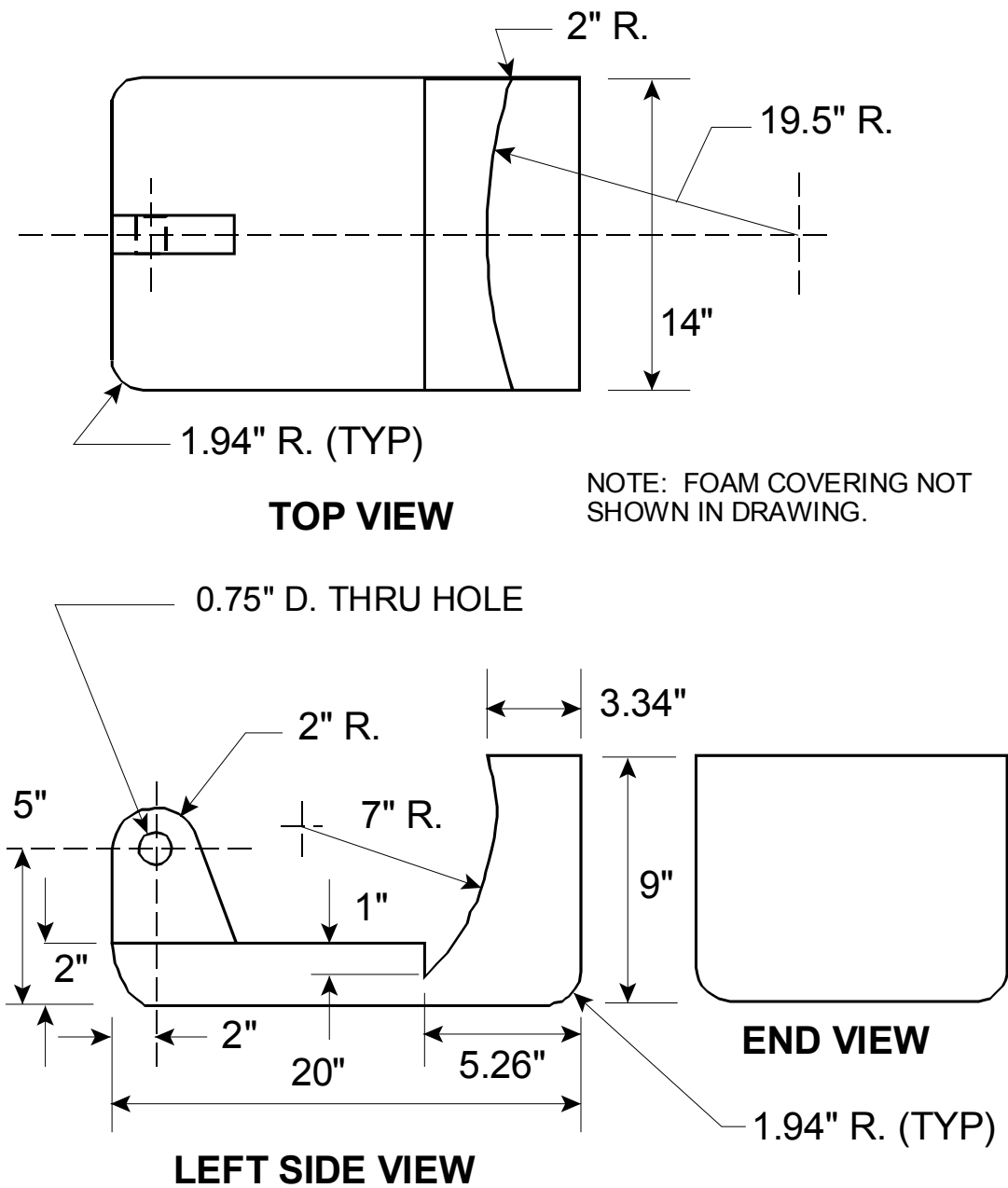

FIGURE 1

12. COMPLIANCE TEST EXECUTION....Continued

NOTE: At the manufacturer's option, the Type B pelvic body block may be substituted for the Type A pelvic body block to apply the specified force to the center set(s) of anchorages for any group of 3 or more sets of anchorages that are simultaneously loaded.

TYPE B LAP BELT BODY BLOCK

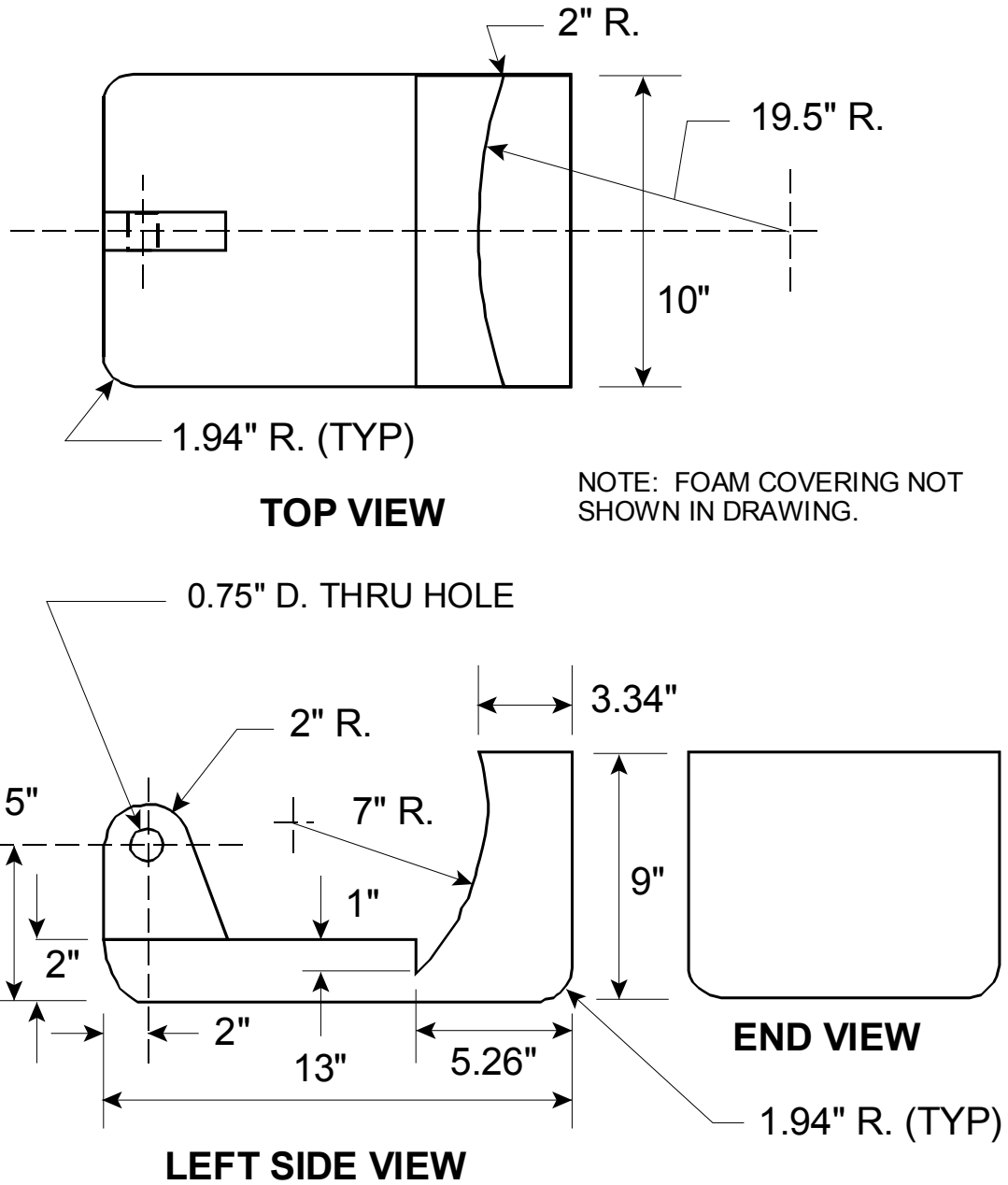

FIGURE 2

12. COMPLIANCE TEST EXECUTION....Continued

SHOULDER BELT BODY BLOCK

FIGURE 3

- F. A SAE two-dimensional manikin or equivalent device to determine the shoulder belt reference point — SHRP (see SAE J826).
- G. A camera to provide pertinent still photographs, which as a minimum, should include the photographs listed in this procedure.

SEQUENCE FOR SEAT BELT ASSEMBLY ANCHORAGE TESTS

The test vehicles shall be subjected to the tests in the order shown below:

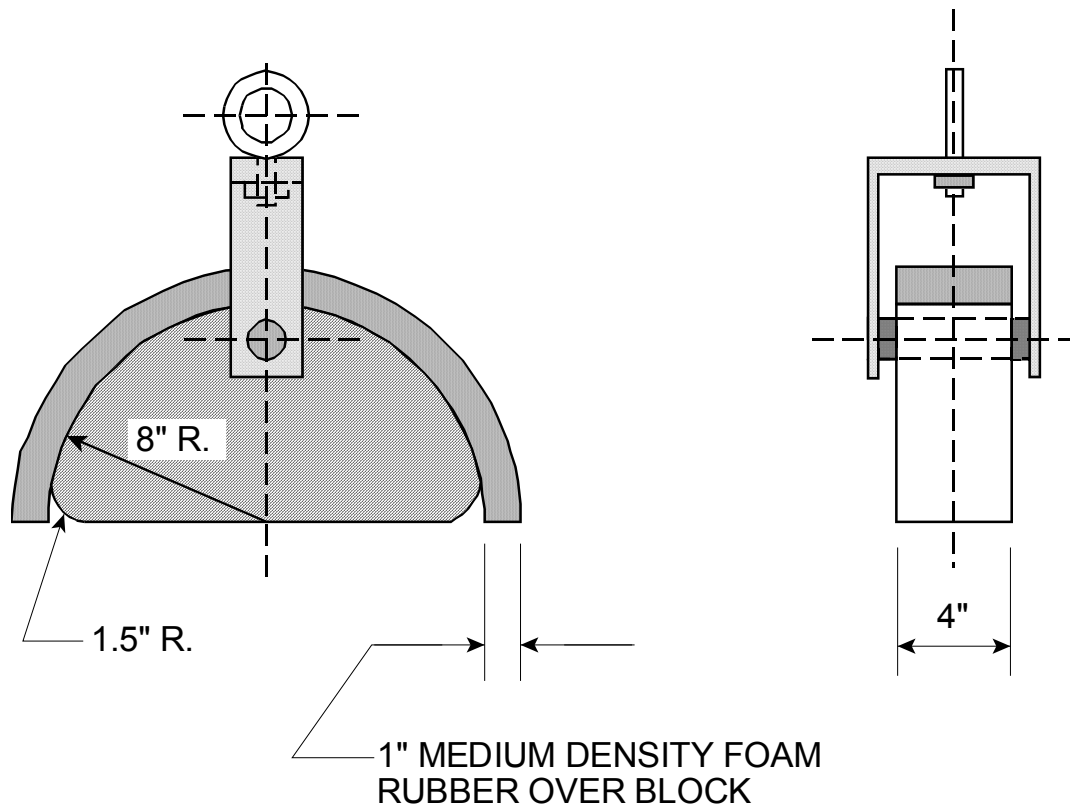
- A. Dimensional measurements
- B. Static load testing of seat belt assembly anchorages

NOTE: All seat belt anchorages will be tested starting at the front of the vehicle and progressing to the rear of the vehicle.

12. COMPLIANCE TEST EXECUTION....Continued

DIMENSIONAL MEASUREMENTS

The number of Designated Seating Positions (DSPs) specified on the test vehicle's tire information label or placard shall be recorded on Data Sheet 1, and the number of seat belt systems in the vehicle compared with this figure (DSPs stipulated for the maximum loading capacity). The type of seat belt system installed at each DSP shall also be recorded on Data Sheet 1; there should be a Type 2 seat belt anchorage system installed for each forward facing outboard DSP and Type 1 anchorages installed for center DSPs.

Measurements shall be made of the lateral spacing of the anchorages for individual seat belt assemblies and recorded on Data Sheet 2. The anchorages for an individual seat belt assembly must be at least 6.5" apart.

Next, the angle from the SRP to the belt attachment hardware shall be measured using the sketch shown in Figure 4 as a guide for the inboard and outboard anchorages at each DSP. Seat back angle and SRP data for each test vehicle will be obtained by the COTR from each manufacturer. Record the information on data Sheet 3.

For each outboard DSP, the shoulder belt anchorages should be located with respect to the shoulder reference point. With the front seat(s) placed in the full rearward and downward position and the seat back(s) in the most upright position the angle from the horizontal of a line projected from the SHRP to the shoulder belt anchorages shall be measured and recorded on Data Sheet 3.

For the lap portion of each seat belt assembly, visually inspect the belt to determine if the belt remains on the pelvis of a 5th percentile female dummy and a 95th percentile male dummy when the seat is adjusted to its rearward and forward most positions. Note the results on Data Sheet 3.

STATIC LOAD TESTING OF SEAT BELT ASSEMBLY ANCHORAGES

A. Preparation of Test Vehicle

- (1) MODIFICATIONS MADE TO THE VEHICLE IN ORDER TO PERFORM THE TEST SHALL BE KEPT TO A MINIMUM. The test laboratory shall notify and obtain approval from the COTR for any required structural cutting or structural removal required on test vehicles prior to the conduct of such actions by the test laboratory.
- (2) If it appears that the seat belt buckle or webbing may incur loading that may cause it to fail, replace the seat belt webbing and or buckles in the area of the body blocks with wire rope.
 - (A) Position the seat as required by the standard

12. COMPLIANCE TEST EXECUTION....Continued

ANCHORAGE & SRP LOCATIONS

BELT OUTSIDE SEAT OR THROUGH SEAT

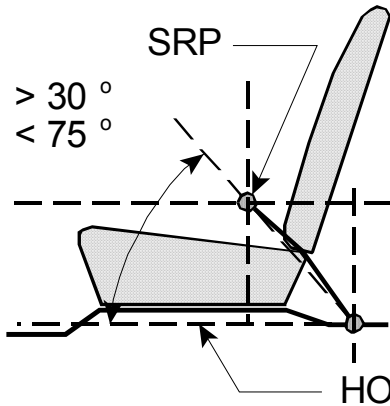

SEAT BELT OVER SEAT CROSSBAR

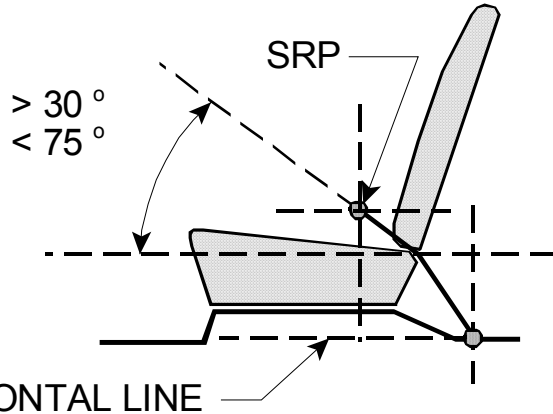

REAR SEAT

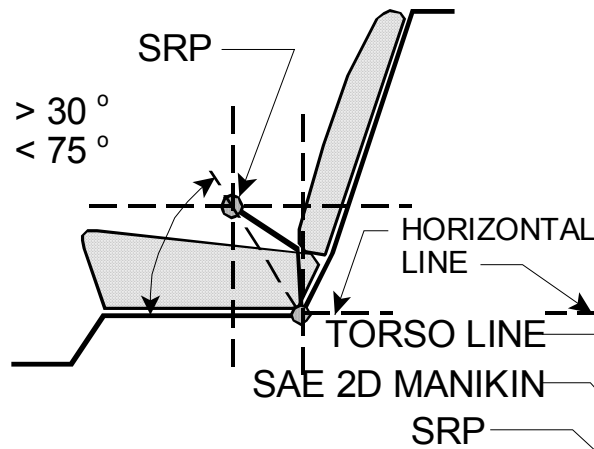

SHOULDER BELTS

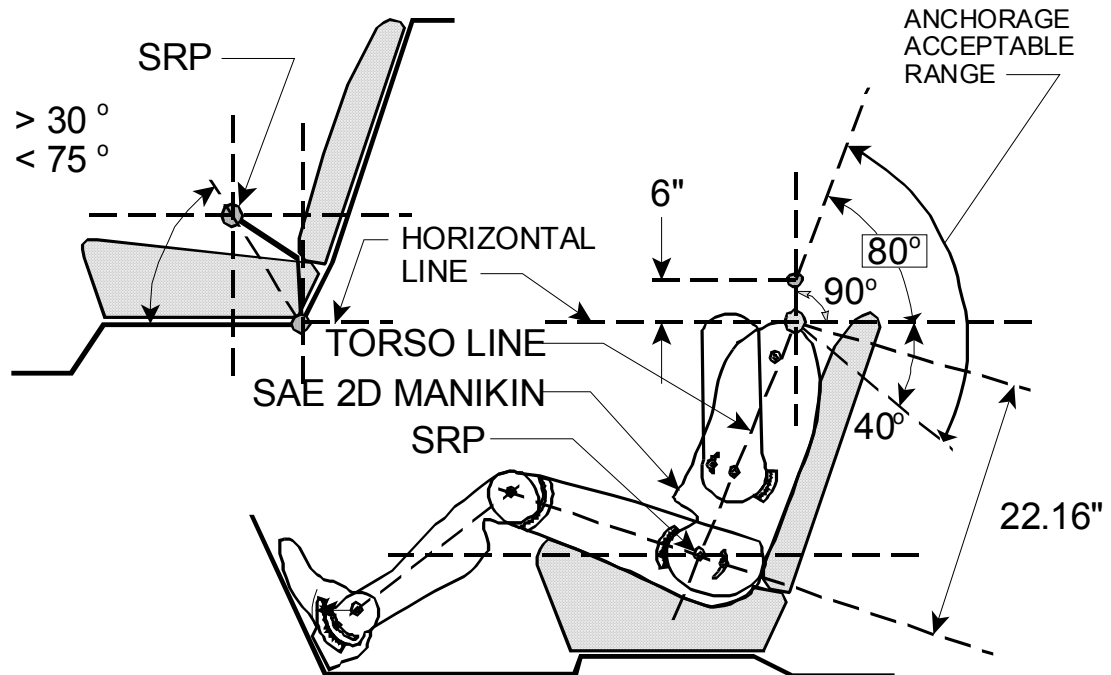

NOTE: Seat is in FULL REARWARD and DOWNWARD position with the seat back in its MOST UPRIGHT position. SAE manikin's H-Point is at the SRP, and the Torso Line is at the same angle from vertical as the seat back.

FIGURE 4

12. COMPLIANCE TEST EXECUTION....Continued

- (B) Position the seat belts around the body blocks
 - (C) Mark the seat belts at the length necessary to position the body blocks
 - (D) Replace the safety belt webbing in the areas that will come into contact with the body block. Remove the buckles that will incur side loading from the body blocks. Retain all hardware, which attaches the safety belt webbing to the anchorages. Attach wire rope securely to the remaining webbing and buckle hardware. The COTR will make the final decision on what will be removed and replaced with wire rope.
- (3) Raise the test vehicle until all 4 wheels are approximately 1" off the test surface and at its curb weight attitude. Secure the test vehicle to prevent lateral and longitudinal movement during belt anchorage load application. Test vehicles must not be restrained by the front or rear bumper systems. Position the test vehicle so that load application angles will be correct (See item A.(5)).
 - (4) Move the front seat(s) to their rearmost position.
 - (5) Attach the load cells to the body block load application cables, and connect the load application device to the load cells. The load application devices shall be positioned such that the angle of pull is $10^{\circ} \pm 4^{\circ}$ above the horizontal. The plane of load application in the plan view shall be adjusted parallel to the test vehicle centerline, $\pm 3^{\circ}$.
 - (6) Perform pretest calibration checks on instrumentation prior to testing, and document for inclusion in the final report. Provide tolerance range indicators on the tracings, chart, or data paper, and provide tolerance range indicators on instruments so that if the test is video taped it shall be apparent that the test was conducted within the test procedure requirements. Identify each recording with date, time, vehicle, test technicians, NHTSA number, chart speed, if applicable, FMVSS number, X and Y axes names, units of measure and instrument settings. Record the serial numbers of equipment used for each specific load application location.

B. Test Performance

- (1) The torso portion of each seat belt assembly and the pelvic portion of a type two seat belt assembly shall be loaded to 3,000 pounds. The pelvic portion of type one seat belt assemblies shall be loaded to 5,000 pounds. The load tolerance for each shall be -10 to -50 pounds. For rearward facing seats that do not have common

12. COMPLIANCE TEST EXECUTION....Continued

anchorages with forward facing seats, the loads will be applied in the rearward direction. For the case where the anchorages are common the COTR will decide which direction the anchorages shall be loaded. All seats on the transverse plane will be loaded simultaneous (i.e., a seat with three DSP's shall have **all three belt systems loaded simultaneously**). The test results shall be recorded on Data Sheet 4.

- (2) Seat Belt Assemblies That Attach to the Seats — Simultaneously apply the appropriate load from item B.(1) plus the seat load required by paragraph 4.2(a) or (b) of FMVSS 207 (See OVSC TP-207)
- (3) All seats shall have the seat belt assembly anchorages load tested. Remove the front seat(s), if necessary to allow access to the rear seat area. Apply loads to the rear seat belt anchorages in the manner of the front belt load applications with the same load tolerance. If there are more than two rows of seats, each row shall be tested in turn by going from the front of the vehicle to the back.
- (4) In a case where there are adjustable seat belt shoulder anchorage points, use the center position for the compliance test. If there is no center position, the COTR will make the final decision as to which position will be tested.
- (5) For each belt load application, all forces shall be adjusted to 10% of target load. While at this load level, photographs and measurements of the load application angles shall be taken. The load application angles shall be recorded on Data Sheet 5. The load shall then be increased to 100% of the target load. After holding the load for a minimum of 10 seconds (load application time from 10% of load can not exceed 30 seconds), the test loads shall be released, anchorages inspected, and all post test photographs taken.
- (6) Descriptions of test vehicle damage resulting from the anchorage loadings shall be recorded on the "Report of Vehicle Condition at the Completion of Testing" form and included in the final report. Permanent deformation, including rupture or breakage, of any anchorage or surrounding area may not constitute a failure. Any anomalies shall be reported immediately to the COTR prior to the next step in testing the vehicle.
- (7) If the seat belt webbing at a particular DSP breaks during the test, the anchorage test for that DSP is terminated at that point and so noted on the data sheet. This would also apply to failed webbing hardware such as buckles and latch plates. Testing of unbroken belts at the other DSPs shall continue to completion.

12. COMPLIANCE TEST EXECUTION....Continued

- (8) If the seat belt webbing breaks or a loading cylinder runs out of stroke, the contractor will reload these anchorages and continue to test after completing the anchorage test on the unbroken belts and anchorages.

13. POST TEST REQUIREMENTS

Contractor shall re-verify all instrumentation and check data sheets.

14. REPORTS

14.1. Monthly Status Reports

The contractor shall submit a monthly Test Status Report and a Vehicle or Equipment Status Report to the COTR. The Vehicle or Equipment Status Report shall be submitted until all vehicles or items of equipment are disposed of. See Figures 12 and 13 for samples of the required Monthly Status Reports.

14.2. Apparent Test Failure

Any indication of a test failure shall be communicated by telephone to the COTR within 24 hours with written notification mailed within 48 hours (Saturday and Sunday hours excluded). A Notice of Test Failure (see Figure 14) with a copy of the particular compliance test data sheet(s) and preliminary data plot(s) shall be included.

In the event of a test failure, a posttest calibration check of some critically sensitive test equipment and instrumentation may be required for verification of accuracy. The necessity for the calibration shall be at the COTR's discretion and shall be performed without additional costs to the OVSC.

14.3. Final Test Reports

14.3.1 Copies

In the case of a test failure, **seven** copies of the Final Test Report shall be submitted to the COTR for acceptance within three weeks of test completion. The Final Test Report format to be used by all contractors can be found in this section.

Where there has been no indication of a test failure, **three** copies of each Final Test Report shall be submitted to the COTR for acceptance within three weeks of test completion. Payment of contractor's invoices for completed compliance tests may be withheld until Final Test Report acceptance by the COTR. Contractors are requested to NOT submit invoices before the COTR is provided with copies of the Final Test Report.

Contractors are required to submit the first Final Test Report in draft form within two weeks after the compliance test is conducted. The contractor and the COTR will then be able to discuss the details of both test conduct and report content early in the compliance test program.

14. REPORTS....Continued

Contractors are required to PROOF READ all Final Test Reports before submittal to the COTR. The OVSC will not act as a report quality control office for contractors. Reports containing a significant number of errors will be returned to the contractor for correction, and a "hold" will be placed on invoice payment for the particular test.

14.3.2 Requirements

The Final Test Report, associated documentation (including photographs) is relied upon as the chronicle of the compliance test. The Final Test Report will be released to the public domain after review and acceptance by the COTR. For these reasons, each final report must be a complete document capable of standing by itself and containing all data sheets.

The contractor should use detailed descriptions of all compliance test events. Any events that are not directly associated with the standard but are of technical interest should also be included. The contractor should include as much detail as possible in the report.

Instructions for the preparation of the first three pages of the final test report are provided for standardization.

14.3.3 First Three Pages

A. FRONT COVER

A heavy paperback cover (or transparency) shall be provided for the protection of the final report. The information required on the cover is as follows:

Final Report Number such as 210-ABC-9X-001, where —

210 is the FMVSS tested
 ABC are the initials for the laboratory
 9X is the Fiscal Year of the test program
 001 is the Group Number (001 for the 1st test, 002 for the 2nd test, etc.)

Final Report Title And Subtitle such as

SAFETY COMPLIANCE TESTING FOR FMVSS 210
 Seat Belt Assembly Anchorages
 * * * * *

Name of Vehicle Manufacturer
 Model Year, Make/Model, Body Style
 NHTSA Number Test Vehicle

Contractor's Name and Address such as

COMPLIANCE TESTING LABORATORIES, INC.
 4335 West Dearborn Street
 Detroit, Michigan 48090

14. REPORTS....Continued

NOTE: DOT SYMBOL WILL BE PLACED BETWEEN ITEMS (3) AND (4)

Date of Final Report Completion such as "March 15, 199X"

The words "FINAL REPORT"

The sponsoring agency's name and address as follows —

U. S. DEPARTMENT OF TRANSPORTATION
National Highway Traffic Safety Administration
Safety Assurance
Office of Vehicle Safety Compliance
400 Seventh Street, SW
Room 6115 (NSA-30)
Washington, DC 20590

14. REPORTS....Continued**B. FIRST PAGE AFTER FRONT COVER**

A disclaimer statement and an acceptance signature block for the COTR shall be provided as follows

This publication is distributed by the U. S. Department of Transportation, National Highway Traffic Safety Administration, in the interest of information exchange. The opinions, findings and conclusions expressed in this publication are those of the author(s) and not necessarily those of the Department of Transportation or the National Highway Traffic Safety Administration. The United States Government assumes no liability for its contents or use thereof. If trade or manufacturers' names or products are mentioned, it is only because they are considered essential to the object of the publication and should not be construed as an endorsement. The United States Government does not endorse products or manufacturers.

Prepared By: _____

Approved By: _____

Approval Date: _____

FINAL REPORT ACCEPTANCE BY OVSC:

Accepted By: _____

Acceptance Date: _____

14. REPORTS....Continued**C. SECOND PAGE AFTER FRONT COVER**

A completed Technical Report Documentation Page (Form DOT F1700.7) shall be completed for those items that are applicable with the other spaces left blank. Sample data for the applicable block numbers of the title page follows.

Block 1 — REPORT NUMBER

210-ABC-9X-001

Block 2 — GOVERNMENT ACCESSION NUMBER

Leave blank

Block 3 — RECIPIENT'S CATALOG NUMBER

Leave blank

Block 4 — TITLE AND SUBTITLE

Final Report of FMVSS 210 Compliance Testing of 199X Ace Super 2-door Coupe, NHTSA No. CX0401

Block 5 — REPORT DATE

March 15, 199X

Block 6 — PERFORMING ORGANIZATION CODE

ABC

Block 7 — AUTHOR(S)

John Smith, Project Manager / Bill Doe, Project Engineer

Block 8 — PERFORMING ORGANIZATION REPORT NUMBER

ABC-DOT-XXX-001

Block 9 — PERFORMING ORGANIZATION NAME AND ADDRESS

ABC Laboratories
405 Main Street
Detroit, MI 48070

14. REPORTS....Continued**Block 10 — WORK UNIT NUMBER**

Leave blank

Block 11 — CONTRACT OR GRANT NUMBER

DTNH22-9X-D-12345

Block 12 — SPONSORING AGENCY NAME AND ADDRESS

US Department of Transportation
National Highway Traffic Safety Administration
Safety Assurance
Office of Vehicle Safety Compliance (NSA-30)
400 Seventh Street, SW, Room 6115
Washington, DC 20590

Block 13 — TYPE OF REPORT AND PERIOD COVERED

Final Test Report
Feb. 15 to Mar. 15, 199X

Block 14 — SPONSORING AGENCY CODE

NEF-30

Block 15 — SUPPLEMENTARY NOTES

Leave blank

Block 16 — ABSTRACT

Compliance tests were conducted on the subject 199X Ace Super 2-door coupe in accordance with the specifications of the Office of Vehicle Safety Compliance Test Procedure No. TP-210-0X for the determination of FMVSS 210 compliance. Test failures identified were as follows:

None

NOTE: Above wording must be shown with appropriate changes made for a particular compliance test. Any questions should be resolved with the COTR.

14. REPORTS....Continued**Block 17 — KEY WORDS**

Compliance Testing
Safety Engineering
FMVSS 210

Block 18 — DISTRIBUTION STATEMENT

Copies of this report are available from —

NHTSA Technical Reference Division
Room 5108 (NAD-52)
400 Seventh St., SW
Washington, DC 20590
Telephone No.: 202-366-4946

Block 19 — SECURITY CLASSIFICATION OF REPORT

Unclassified

Block 20 — SECURITY CLASSIFICATION OF PAGE

Unclassified

Block 21 — NUMBER OF PAGES

Add appropriate number

Block 22 — PRICE

Leave blank

14. REPORTS....Continued

14.3.4 Table of Contents

Final test report Table of Contents shall include the following:

Section 1 -- Purpose of Compliance Test

Section 2 -- Compliance Test Data Summary

Section 3 -- Compliance Test Data

Section 4 -- Noncompliance Data (if applicable)

Section 5 -- Photographs

15. DATA SHEETS

DATA SHEET 1

SEAT BELT ASSEMBLY ANCHORAGE INSTALLATION TYPES

VEH. MOD YR/MAKE/MODEL/BODY: _____

VEH. NHTSA NO.: _____ ; VIN: _____

VEH. BUILD DATE: _____ ; TEST DATE: _____

TEST LABORATORY: _____

OBSERVERS: _____

Number of DSPs in Test Vehicle As Stated On Tire Label using Figures For Maximum Vehicle Loading

Front Seat = _____

Rear Seat = _____

Third Seat = _____

TOTAL = _____

| SEAT | SEATING POSITION | SEAT FACING | REQUIRED ANCHORAGE | OBSERVED ANCHORAGE |
|-------------|------------------|-------------|--------------------|--------------------|
| FRONT | Outboard-Left | Forward | Type 2 | |
| | Center | Forward | Type 1 | |
| | Outboard-Right | Forward | Type 2 | |
| REAR | Outboard-Left | Forward | Type 2* | |
| | Center | Forward | Type 1 | |
| | Outboard-Right | Forward | Type 2* | |
| THIRD | Outboard-Left | Rearward | Type 1 | |
| | Center | Rearward | Type 1 | |
| | Outboard-Right | Rearward | Type 1 | |
| SIDE FACING | Left | Side | Type 1 | |
| | Right | Side | Type 1 | |

* SEE NEXT PAGE

15. DATA SHEETS....Continued

* It may be necessary to cut the test vehicle's headlining material or cut/remove trim panels in order to verify the existence of shoulder belt anchorage provisions. Care should be taken to cause no more damage than necessary.

For vehicles without manufacturer installed rear outboard Type 2 seat belts, does the owner's manual have a diagram of the location of the shoulder belt anchorages?

_____ Yes _____ No

If yes, attach a copy of the diagram.

REMARKS:

RECORDED BY: _____

DATE: _____

APPROVED BY: _____

15. DATA SHEETS....Continued

DATA SHEET 2

LATERAL SPACING OF SEAT BELT ASSEMBLY ANCHORAGES

VEH. MOD YR/MAKE/MODEL/BODY: _____

VEH. NHTSA NO.: _____; VIN: _____

VEH. BUILD DATE: _____; TEST DATE: _____

TEST LABORATORY: _____

OBSERVERS: _____

| SEAT | ANCHORAGE LOCATION | MEASURED SPACING |
|-------------|----------------------------|------------------|
| FRONT | Left Outer - Left Inner | |
| | Center Left - Center Right | |
| | Right Inner - Right Outer | |
| REAR | Left Outer - Left Inner | |
| | Center Left - Center Right | |
| | Right Inner - Right Outer | |
| THIRD | Left Outer - Left Inner | |
| | Left Inner - Right Inner | |
| | Right Inner - Right Outer | |
| SIDE FACING | | |

NOTE: The spacing for an individual seat belt assembly anchorage shall be at least 6.5" apart as measured between the vertical centerlines of the boltholes.

REMARKS:

RECORDED BY: _____

DATE: _____

APPROVED BY: _____

15. DATA SHEETS....Continued

DATA SHEET 3

SEAT BELT ANGLES

VEH. MOD YR/MAKE/MODEL/BODY: _____

VEH. NHTSA NO.: _____; VIN: _____

VEH. BUILD DATE: _____; TEST DATE: _____

TEST LABORATORY: _____

OBSERVERS: _____

LAP BELT ANCHORAGES:

| SEAT | SEATING POSITION | SPECIFIED ANGLE RANGE ABOVE HORIZONTAL | MEASURED ANGLE | | DOES BELT SECURELY FIT ON PELVIS? |
|-------------|------------------|--|----------------|-----|-----------------------------------|
| | | | I/B | O/B | |
| FRONT | Left | 30 to 75 degrees | | | |
| | Center | 30 to 75 degrees | | | |
| | Right | 30 to 75 degrees | | | |
| REAR | Left | 30 to 75 degrees | | | |
| | Center | 30 to 75 degrees | | | |
| | Right | 30 to 75 degrees | | | |
| THIRD | Left | 30 to 75 degrees | | | |
| | Center | 30 to 75 degrees | | | |
| | Right | 30 to 75 degrees | | | |
| SIDE FACING | Left Side | 30 to 75 degrees | | | |
| | Right Side | 30 to 75 degrees | | | |

REMARKS:

15. DATA SHEETS....Continued

SHOULDER BELT ANCHORAGES:

| SEAT | SEATING POSITION | SPECIFIED ANGLE RANGE ABOVE OR BELOW HORIZONTAL | MEASURED ANGLE |
|-------|------------------|---|----------------|
| FRONT | Left | 0 - 80 degrees above | |
| | | 0 - 40 degrees below | |
| | Right | 0 - 80 degrees above | |
| | | 0 - 40 degrees below | |
| REAR | Left | 0 - 80 degrees above | |
| | | 0 - 40 degrees below | |
| | Right | 0 - 80 degrees above | |
| | | 0 - 40 degrees below | |

REMARKS:

SHOULDER BELTS

ANCHORAGE ACCEPTABLE RANGE

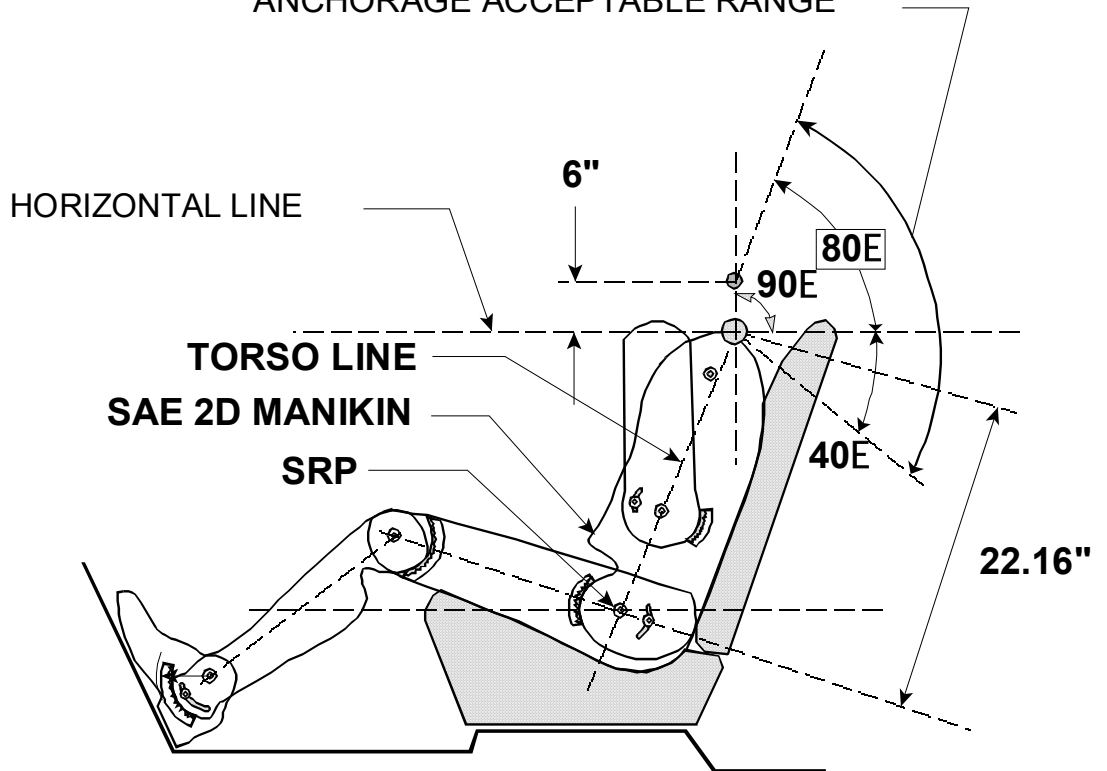

RECORDED BY: _____

DATE: _____

APPROVED BY: _____

15. DATA SHEETS...Continued

DATA SHEET 4

LAP AND SHOULDER BELT ASSEMBLY ANCHORAGE LOADINGS

VEH. MOD YR/MAKE/MODEL/BODY: _____

VEH. NHTSA NO.: _____ ; VIN: _____

VEH. BUILD DATE: _____ ; TEST DATE: _____

TEST LABORATORY: _____

OBSERVERS: _____

| SEAT | BELT ASSEMBLY TESTED | MAXIMUM LOAD REQUIREMENT | APPLIED LOAD |
|-------|----------------------|--------------------------|--------------|
| FRONT | Left Lap | 5,000 lbs, -10, -50 | |
| | Left Shoulder | 3,000 lbs, -10, -50 | |
| | Right Lap | 5,000 lbs, -10, -50 | |
| | Right Shoulder | 3,000 lbs, -10, -50 | |
| | Center Lap | 5,000 lbs, -10, -50 | |
| REAR | Left Lap | 5,000 lbs, -10, -50 | |
| | Left Shoulder | 3,000 lbs, -10, -50 | |
| | Right Lap | 5,000 lbs, -10, -50 | |
| | Right Shoulder | 3,000 lbs, -10, -50 | |
| | Center Lap | 5,000 lbs, -10, -50 | |
| THIRD | Left Lap | 5,000 lbs, -10, -50 | |
| | Left Shoulder | 3,000 lbs, -10, -50 | |
| | Right Lap | 5,000 lbs, -10, -50 | |
| | Right Shoulder | 3,000 lbs, -10, -50 | |
| | Center Lap | 5,000 lbs, -10, -50 | |

REMARKS:

15. DATA SHEETS....Continued

DATA SHEET 5

SEAT BELT ASSEMBLY LOAD ANGLE MEASUREMENT

VEH. MOD YR/MAKE/MODEL/BODY: _____

VEH. NHTSA NO.: _____; VIN: _____

VEH. BUILD DATE: _____; TEST DATE: _____

TEST LABORATORY: _____

OBSERVERS: _____

| TYPE | ANGLE MEASURED | ANGLE REFERENCE | ANGLE AT 10% LOAD (degrees) | | | | | | |
|---------------|----------------------------------|--|-----------------------------|----|----------|----|-----------|----|--|
| | | | LEFT DSP | | CNTR DSP | | RIGHT DSP | | |
| | | | FRT | RR | FRT | RR | FRT | RR | |
| LAP BELT | Load Application Angle (degrees) | From Side View Horizontal 10 ± 4 | | | | | | | |
| | | From Plan View Vehicle Centerline 0 ± 3 | | | | | | | |
| SHOULDER BELT | Load Application Angle (degrees) | From Side View Horizontal 10 ± 4 | | | | | | | |
| | | From Plan View Vehicle Centerline 0 ± 3 | | | | | | | |

REMARKS:

RECORDED BY: _____

DATE: _____

APPROVED BY: _____

15. DATA SHEETS....Continued

DATA SHEET 6

TEST VEHICLE RECEIVING-INSPECTION

VEH. MOD YR/MAKE/MODEL/BODY: _____

VEH. NHTSA NO.: _____; VIN: _____

VEH. BUILD DATE: _____; TEST DATE: _____

TEST LABORATORY: _____

OBSERVERS: _____

1. First compliance test by laboratory for this vehicle is S210 test.

 Yes No (Go to item 2) 1.1 Label test vehicle with NHTSA Number 1.2 Verify all options on the "window sticker" are present on the vehicle 1.3 Verify tires and wheel rims are new and the same as listed 1.4 Verify there are no dents or other interior or exterior flaws 1.5 Verify the glove box contains an owner's manual, warranty document, consumer information, and extra keys 1.6 Verify the vehicle is equipped with the proper fuel filler cap 1.7 If the vehicle has been delivered from the dealer, verify the vehicle has been properly prepared and is in running condition

2. Verify seat adjusters are working

 Yes No

3. Verify there is a seat belt at each seating position

 Yes No

4. Without disturbing the integrity of each seat belt and anchorage, verify that each seat belt is attached to the anchorage. For seat belts that are attached to the seat, also verify the seats are attached to the seat anchors and the seat anchors are attached to the vehicle.

 Yes No

15. DATA SHEETS...Continued

5. REMARKS: (Explain any problems here)

RECORDED BY: _____ DATE: _____

APPROVED BY: _____

16. FORMS

LABORATORY NOTICE OF TEST FAILURE TO OVSC

FMVSS NO.: 210 TEST DATE: _____

LABORATORY: _____

CONTRACT NO.: DTNH22-_____; DELV. ORDER NO.: _____

LABORATORY PROJECT ENGINEER'S NAME: _____

TEST VEHICLE MAKE/MODEL/BODY STYLE: _____

VEHICLE NHTSA NO.: _____; VIN: _____

VEHICLE MODEL YEAR: _____; BUILD DATE: _____

TEST FAILURE DESCRIPTION: _____

S210 REQUIREMENT, PARAGRAPH ____ : _____

NOTIFICATION TO NHTSA (COTR) : _____

DATE: _____ BY: _____

REMARKS: _____

16. FORMS....Continued

MONTHLY TEST STATUS REPORT

FMVSS 210

DATE OF REPORT: _____

| No. | VEHICLE NHTSA No., MAKE & MODEL | COMPLIANCE TEST DATE | PASS/ FAIL | DATE REPORT SUBMITTED | DATE INVOICE SUBMITTED | INVOICE PAYMENT DATE |
|-----|------------------------------------|-------------------------|---------------|-----------------------------|------------------------------|----------------------------|
| 1 | | | | | | |
| 2 | | | | | | |
| 3 | | | | | | |
| 4 | | | | | | |
| 5 | | | | | | |
| 6 | | | | | | |
| 7 | | | | | | |
| 8 | | | | | | |
| 9 | | | | | | |
| 10 | | | | | | |
| 11 | | | | | | |
| 12 | | | | | | |
| 13 | | | | | | |
| 14 | | | | | | |
| 15 | | | | | | |
| 16 | | | | | | |
| 17 | | | | | | |
| 18 | | | | | | |
| 19 | | | | | | |
| 20 | | | | | | |

16. REPORT FORMS....Continued

MONTHLY VEHICLE STATUS REPORT

FMVSS 210

DATE OF REPORT: _____

| No. | VEHICLE NHTSA No., MAKE & MODEL | DATE OF DELIVERY | TEST COMPLETE DATE | VEHICLE SHIPMENT DATE | CONDITION OF VEHICLE |
|-----|------------------------------------|---------------------|--------------------------|-----------------------------|-------------------------|
| 1 | | | | | |
| 2 | | | | | |
| 3 | | | | | |
| 4 | | | | | |
| 5 | | | | | |
| 6 | | | | | |
| 7 | | | | | |
| 8 | | | | | |
| 9 | | | | | |
| 10 | | | | | |
| 11 | | | | | |
| 12 | | | | | |
| 13 | | | | | |
| 14 | | | | | |
| 15 | | | | | |
| 16 | | | | | |
| 17 | | | | | |
| 18 | | | | | |
| 19 | | | | | |
| 20 | | | | | |

APPENDIX A

MOTOR VEHICLE SAFETY STANDARD NO. 210 Seat Belt Assembly Anchorages — Passenger Cars, Multipurpose Passenger Vehicles, Trucks, and Buses (Docket No. 2-14; Notice No. 4)

S1. PURPOSE AND SCOPE

This standard establishes requirements for seat belt assembly anchorages to insure their proper location for effective occupant restraint and to reduce the likelihood of their failure.

S2. APPLICATION

This standard applies to passenger cars, multipurpose passenger vehicles, trucks, and buses.

S3. DEFINITION

Seat belt anchorage means any component, other than the webbing or straps, involved in transferring seat belt loads to the vehicle structure, including, but not limited to, the attachment hardware, seat frames, seat pedestals, the vehicle structure itself, and any part of the vehicle whose failure causes separation of the belt from the vehicle structure.

S4. REQUIREMENTS

S4.1 Type

- S4.1.1 Seat belt anchorages for a Type 2 seat belt assembly shall be installed for each forward-facing outboard designated seating position in passenger cars, other than convertibles, and for each designated seating position for which a Type 2 seat belt assembly is required by Standard No. 208 (49 CFR 571.208) in vehicles other than passenger cars. Seat belt anchorages for a Type 2 seat belt assembly shall be installed for each rear forward facing outboard-designated seating position in convertible passenger cars manufactured on or after September 1, 1991.
- S4.1.2 Seat belt anchorages for a Type 1 or a Type 2 seat belt assembly shall be installed for each designated seating position, except a passenger seat in a bus or a designated seating position for which seat belt anchorages for a Type 2 seat belt assembly are required by S4.1.1.
- S4.1.3 (a) Notwithstanding the requirement of S4.1.1, each vehicle manufactured on or after September 1, 1987, that is equipped with an automatic restraint at the front right outboard-designated seating

APPENDIX A...Continued

position, which automatic restraint cannot be used for securing a child restraint system solely through the use of attachment hardware installed as an item of original equipment by the vehicle manufacturer shall have, at the manufacturer's option, either anchorages for a Type 1 seat belt assembly installed at that position or a Type 1 or Type 2 seat belt assembly installed at the position. If a manufacturer elects to install anchorages for a Type 1 seat belt assembly to comply with this requirement, those anchorages shall consist of, at a minimum, holes threaded to accept bolts complying with S4.1(f) of Standard No. 209 (49 CFR 571.209).

- (b) The requirement in S4.1.1 and S4.1.2 of this standard that seat belt anchorages for a Type 1 or a Type 2 seat belt assembly shall be installed for certain designated seating positions does not apply to any such seating positions that are equipped with a seat belt assembly that meets the frontal crash protection requirements of S5.1 of Standard No. 208 (49 CFR 571.208).

S4.2 Strength

- S4.2.1 Except as provided in S4.2.5, and except for side-facing seats, the anchorages, attachment hardware, and attachment bolts for any of the following seat belt assemblies shall withstand a 5,000-pound force when tested in accordance with S5.1 of this standard
 - (a) Type 1 seat belt assembly;
 - (b) Lap belt portion of either a Type 2 or automatic seat belt assembly, if such seat belt assembly is voluntarily installed at a seating position; and
 - (c) Lap belt portion of either a Type 2 or automatic seat belt assembly, if such seat belt assembly is equipped with a detachable upper torso belt.
- S4.2.2 Except as provided in S4.2.5, the anchorages, attachment hardware, and attachment bolts for all Type 2 and automatic seat belt assemblies that are installed to comply with Standard No. 208 (49 CFR 571.208) shall withstand 3,000 pound forces when tested in accordance with S5.2.
- S4.2.3 Permanent deformation or rupture of a seat belt anchorage or its surrounding area is not considered to be a failure, if the required force is sustained for the specified time.
- S4.2.4 Anchorages, attachment hardware, and attachment bolts shall be tested by simultaneously loading them in accordance with the applicable procedures set forth in S5 of this standard if the anchorages are either

APPENDIX A...Continued

- (a) For designated seating positions that are common to the same occupant seat and that face in the same direction; or
- (b) For laterally adjacent designated seating positions that are not common to the same occupant seat, but that face in the same direction, if the vertical centerline of the bolt hole for at least one of the anchorages for one of those designated seating positions is within 12 inches of the vertical centerline of the bolt hole for an anchorage for one of the adjacent seating positions.

S4.2.5 The attachment hardware of a seat belt assembly, which is subject to the requirements of S5.1 of Standard No. 208 (49 CFR 571.208) by virtue of any provision of Standard No. 208 (49 CFR 571.208) by virtue of any provision of Standard No. 208 other than S4.1.2.1(c)(2) of that standard, does not have to meet the requirements of S4.2.1 and S4.2.2 of this standard.

S4.3 Location

As used in this section, "forward" means in the direction in which the seat faces, and other directional references are to be interpreted accordingly. Anchorages for seat belt assemblies that meet the frontal crash protection requirements of S5.1 of Standard No. 208 (49 CFR Part 571.208) are exempt from the location requirements of this section.

S4.3.1 Seat belt anchorages for Type 1 seat belt assemblies and the pelvic portion of Type 2 seat belt assemblies.

S4.3.1.1 In an installation in which the seat belt does not bear upon the seat frame —

- (a) If the seat is a nonadjustable seat, then a line from the seating reference point to the nearest contact point of the belt with the anchorage shall extend forward from the anchorage at an angle with the horizontal of not less than 30 degrees and not more than 75 degrees.
- (b) If the seat is an adjustable seat, then a line from a point 2.50 inches forward of and 0.375 inch above the seating reference point to the nearest contact point of the belt with the anchorage shall extend forward from the anchorage at an angle with the horizontal of not less than 30 degrees and not more than 75 degrees.

S4.3.1.2 In an installation in which the belt bears upon the seat frame, the seat belt anchorage, if not on the seat structure, shall be aft of the rearmost belt contact point on the seat frame with the seat in the rearmost position. The line from the seating reference point to the nearest belt contact point on the seat frame, with the seat positioned at the seating reference point, shall extend forward from that contact point at an angle with the horizontal of not less than 30 degrees and not more than 75 degrees.

APPENDIX A....Continued

- S4.3.1.3 In an installation in which the seat belt attaches to the seat structure, the line from the seating reference point to the nearest contact point of the belt with the hardware attaching it to the seat structure shall extend forward from that contact point at an angle with the horizontal of not less than 30 degrees and not more than 75 degrees.
- S4.3.1.4 Anchorages for an individual seat belt assembly shall be located at least 6.50 inches apart laterally, measured between the vertical centerline of the bolt holes [or, for designs using another means of attachment to the vehicle structure, between the centroid of such means. (57 F.R. 32902 July 24, 1992. Effective: September 1, 1993.)
- S4.3.1.5 Notwithstanding the provisions of S4.3.1.1 through S4.3.1.4, the lap belt angle for seats behind the front row of seats shall be between 20 degrees and 75 degrees for vehicles manufactured between September 1, 1992 and September 1, 1993.
- S4.3.2 Seat belt anchorages for the upper torso portion of Type 2 seat belt assemblies. Adjust the seat to its full rearward and downward position and adjust the seat back to its most upright position. With the seat and seat back so positioned, as specified by subsection (a) or (b) of this section, the upper end of the upper torso restraint shall be located within the acceptable range shown in Figure 1, with reference to a two-dimensional drafting template described in SAE Recommended Practice J826 (May 1987). The template's "H" point shall be at the design "H" point of the seat for its full rearward and full downward position, as defined in SAE Recommended Practice J1100 (June 1984), and the template's torso line shall be at the same angle from the vertical as the seat back.
- (a) For fixed anchorages, compliance with this section shall be determined at the vertical centerline of the boltholes or, for designs using another means of attachment to the vehicle structure, at the centroid of such means.
 - (b) For adjustable anchorages, compliance with this section shall be determined at the midpoint of the range of all adjustment positions. (57 F.R. 32902 July 24, 1992. Effective: September 1, 1993.)

S5. TEST PROCEDURES

Each vehicle shall meet the requirements of S4.2 of this standard when tested according to the following procedures. Where a range of values is specified, the vehicle shall be able to meet the requirements at all points within the range.

APPENDIX A...Continued

For the testing specified in these procedures, the anchorage shall be connected to material whose breaking strength is equal to or greater than the breaking strength of the webbing for the seat belt assembly installed as original equipment at that seating position. The geometry of the attachment duplicates the geometry, at the initiation of the test, of the attachment of the originally installed seat belt assembly.

LOCATION OF ANCHORAGE FOR UPPER TORSO RESTRAINT

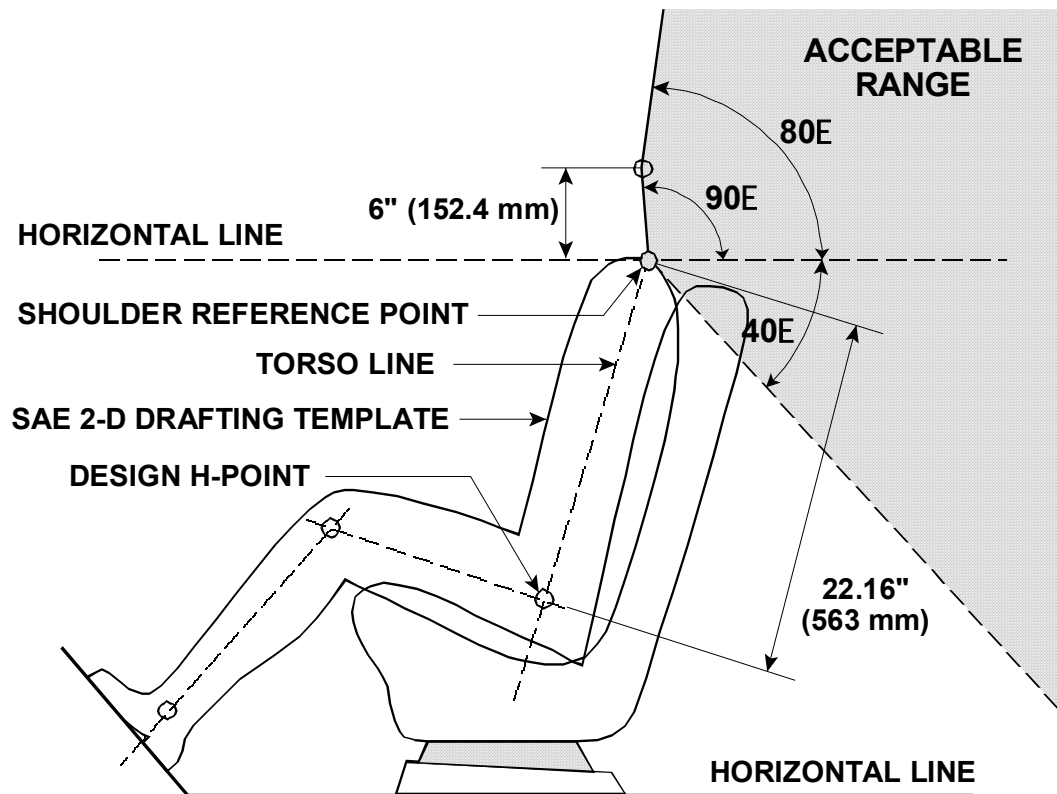

FIGURE 1

S5.1 Seats with Type 1 or Type 2 Seat Belt Anchorages

With the seat in its rearmost position, apply a force of 5,000 pounds in the direction in which the seat faces to a pelvic body block as described in Figure 2A, in a plane parallel to the longitudinal centerline of the vehicle, with an initial force application angle of not less than 5 degrees nor more than 15 degrees above the horizontal. Apply the force at the onset rate of not more than 50,000 pounds per second. Attain the 5,000-pound force in not more than 30 seconds and maintain it for 10 seconds. At the manufacturer's option, the pelvic body block described in Figure 2B may be substituted for the pelvic body block described in Figure 2A to apply the specified force to the center set(s) of anchorages for any group of three or more sets of anchorages that are simultaneously loaded in accordance with S4.2.4 of this standard.

APPENDIX A...Continued

S5.2 Seats with Type 2 Seat Belt Anchorages

With the seat in its rearmost position, apply forces of 3,000 pounds in the direction in which the seat faces simultaneously to a pelvic body block, as

BODY BLOCK FOR LAP BELT ANCHORAGE

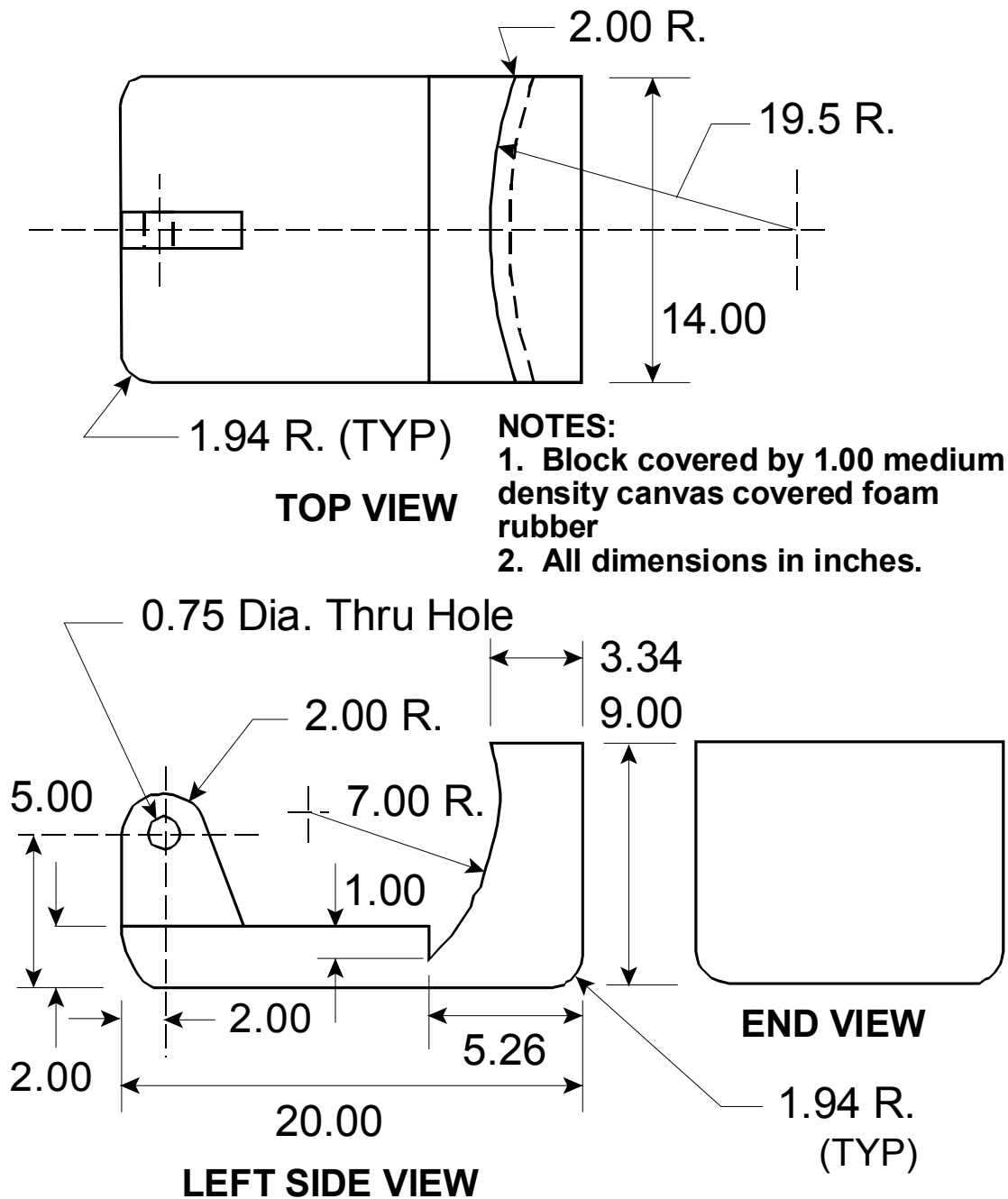

FIGURE 2A

OPTIONAL BODY BLOCK FOR CENTER SEATING POSITIONS

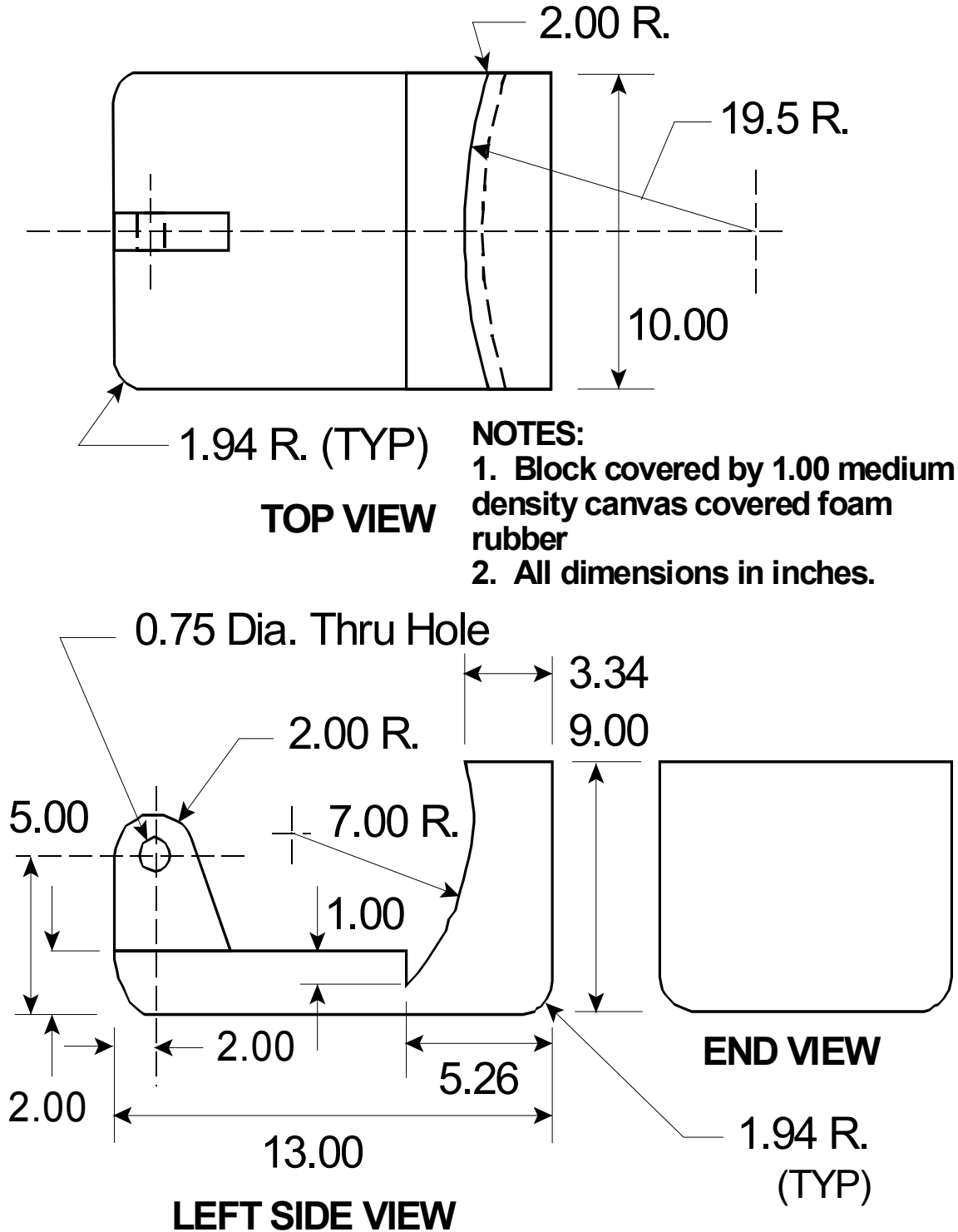

FIGURE 2B

APPENDIX A....Continued

described in Figures 2A, and an upper torso body block, as described in Figure 3, in a plane parallel to the longitudinal centerline of the vehicle, with an initial force application angle of not less than 5 degrees nor more than 15 degrees above the horizontal. Apply the forces at the onset rate of not more than 30,000 pounds per second. Attain the 3,000-pound forces in not more than 30 seconds and maintain it for 10 seconds. At the manufacturer's option, the pelvic body block described in Figure 2B may be substituted for the pelvic body block described in Figure 2A to apply the specified force to the center set(s) of anchorages for any group of three or more sets of anchorages that are simultaneously loaded in accordance with S4.2.4 of this standard.

S6. OWNER'S MANUAL INFORMATION

The owner's manual in each vehicle with GVWR of 10,000 pounds or less, manufactured after September 1, 1987, shall include —

- (a) A section explaining that all child restraint systems are designed to be secured in vehicle seats by lap belts or the lap belt portion of a lap-shoulder belt. The section shall also explain that children could be endangered in a crash if their child restraints are not properly secured in the vehicle.
- (b) In a vehicle with rear designated seating positions, a statement alerting vehicle owners that, according to accident statistics, children are safer when properly restrained in the rear seating positions than in the front seating positions.
- (c) In each passenger car, a diagram or diagrams showing the location of the shoulder belt anchorages required by this standard for the rear outboard designated seating positions, if shoulder belts are not installed as items of original equipment by the vehicle manufacturer at those positions.

S7. INSTALLATION INSTRUCTIONS

The owner's manual in each vehicle manufactured on or after September 1, 1987, with an automatic restraint at the front right outboard designated seating position that cannot be used to secure a child restraint system when the automatic restraint is adjusted to meet the performance requirements of S5.1 of Standard No. 208 shall have —

- (a) A statement that the automatic restraint at the front right outboard designated seating position cannot be used to secure a child restraint and as appropriate, one of the following three statements —
 - (1) A statement that the automatic restraint at the front right outboard

APPENDIX A....Continued

designated seating position can be adjusted to secure a child restraint system using attachment hardware installed as original equipment by the vehicle manufacturer;

- (2) A statement that anchorages for installation of a lap belt to secure a child restraint system have been provided at the front right outboard designated seating position; or
 - (3) A statement that a lap or manual lap or lap/shoulder belt has been installed by the vehicle manufacturer at the front right outboard designated seating position to secure a child restraint.
- (b) In each vehicle in which a lap or lap/shoulder belt is not installed at the front right outboard designated seating position as an item of original equipment, but the automatic restraint at that position can be adjusted by the vehicle owner to secure a child restraint system using an item or items of original equipment installed in the vehicle by the vehicle manufacturer, the owner's manual shall also have
- (1) A diagram or diagrams showing the location of the attachment hardware provided by the vehicle manufacturer.
 - (2) A step-by-step procedure with a diagram or diagrams showing how to modify the automatic restraint system to secure a child restraint system. The instructions shall explain the proper routing of the attachment hardware.
- (c) In each vehicle in which the automatic restraint at the front right outboard designated seating position cannot be modified to secure a child restraint system using attachment hardware installed as an original equipment by the vehicle manufacturer and a manual lap or lap/shoulder belt is not installed as an item of original equipment by the vehicle manufacturer, the owner's manual shall also have —
- (1) A diagram or diagrams showing the locations of the lap belt anchorages for the front right outboard designated seating position.
 - (2) A step-by-step procedure and a diagram or diagrams for installing the proper lap belt anchorage hardware and a Type 1 lap belt at the front right outboard designated seating position. The instructions shall explain the proper routing of the seat belt assembly and the seat belt attachment of the assembly to the lap belt anchorages. H

APPENDIX B
MOTOR VEHICLE SEAT BELT ANCHORAGES — DESIGN RECOMMENDATIONS
SAE J383 APR86
SAE Recommended Practice

1. SCOPE

This SAE Recommended Practice specifies design recommendations for location of seat belt assembly anchorages. It applies to seat belt anchorages attached to vehicle structure or installed to seat assemblies in the vehicle (this SAE Recommended Practice supersedes the Design Section of SAE J787b). Test Procedures and Performance Requirements are specified in SAE J384, Motor Vehicle Seat Belt Anchorages — Test Procedure, and SAE J385, Motor Vehicle Seat Belt Anchorages — Performance Requirements, respectively.

2. DEFINITIONS

2.1 ANCHORAGE

The final point of attachment for transferring seat belt assembly loads to the vehicle structure.

2.2 SEATING REFERENCE POINT (SRP)

The Design H-Point with the seat in the rearmost, lowest normal design position. (The "Design H-Point" has coordinates relative to the design vehicle structure. It is located at the H-Point of the two-dimensional drafting template placed in any designated seating position (DSP).)

2.3 SHOULDER REFERENCE POINT (SRP)

A point 22.16 inches (563 mm) above the "H" Point along the torso centerline of the two-dimensional drafting template described in SAE J826. This dimension added to the dimension of 3.84 inches (97.5 mm) from the "H" Point to the buttocks flesh line and an angular relationship of 90 degrees between the torso and thigh segment of the two-dimensional drafting template has been indicated to represent 99 percent of the male driver population.

2.4 ATTACHMENT HARDWARE

Any or all hardware designed for securing a seat belt assembly to the anchorage(s) in a motor vehicle.

2.5 SEAT BELT ASSEMBLY

Any strap, webbing, or similar device designed to secure a person in a motor vehicle with the intention of minimizing the risk of bodily harm in an accident,

APPENDIX B...Continued

including all buckles, adjusting mechanism, fasteners, and related hardware. This SAE Recommended Practice covers anchorages for the following types of assemblies:

Type 1 — Pelvic restrain belt (lap belt).

Type 2 — Combination of pelvic (lap) and upper torso (shoulder) restraints belts.

Type 2a — Upper torso (shoulder) restraint for use only in conjunction with a pelvic restraint (lap) belt as a Type 2 seat belt assembly.

2.6 BELT CONTACT POINT

The point where the seat belt webbing's longitudinal centerline would make contact with the load bearing member of the seat structure, body structure, retractor hardware (or webbing wound on the spool of a retractor), or attachment hardware such as a swivel plate which may be bolted to the seat belt anchorage. The components on which belt contact point is located must be capable of sustaining a load that might be imposed by the webbing of a seat belt assembly.

2.7 BELT ANGLE REFERENCE POINT

The point 2.50 inches (63.5 mm) forward of and 0.375 inches (9.5 mm) above the seating reference point (SRP).

3. GENERAL

3.1 INSTALLATION AND REPLACEMENT

Anchorage shall permit seat belt assemblies to be readily installed or replaced, and shall comply with the strength requirements of SAE J385.

3.2 COMMON ANCHORAGE(S)

A common anchorage point may be used for more than one belt end, provided it meets the pertinent requirements of paragraph 4.4 and SAE J385. The location of the lower anchorage(s) of the upper torso restraint may be common with the pelvic restraint anchorage(s).

4. LOCATION OF PELVIC RESTRAINT ANCHORAGES

4.1 PELVIC RESTRAINT ANGLE GUIDELINES

Many factors affect the preferred more vertical pelvic restraint belt angle, which is

APPENDIX B...Continued

basically intended to prevent the lap belt from sliding over the iliac crest during the forward and downward movement of the restrained individual.

Ideally, component tests, sled tests or vehicle crash tests should be run, utilizing a test device containing a humanlike ilium with appropriate "soft tissue" damping in relation to the spine and femur along with humanlike abdominal contents, to determine the preferred pelvic restraint belt angle which is influenced by any or all of the following factors:

- (a) Seat cushion compression and/or seat deflection
- (b) Seat cushion angle and seat back angle
- (c) Proximity of "hard" vehicle structures in front of the restrained occupant
- (d) Initial length and elongation characteristics of belt webbing
- (e) Type of restraint system
- (f) Presence or absence of upper torso restraint belt
- (g) Placement of upper torso restraint anchorage
- (h) Stiffness of components or structures on which are found the belt contact points

In the absence of component tests, sled tests or vehicle crash tests, a more vertical pelvic restraint belt angle is preferred and should be selected within the range of 20 to 75 degrees from the horizontal.

4.2 ANCHORAGES ON VEHICLE STRUCTURE FOR PELVIC RESTRAINT BELTS

4.2.1 MOVABLE SEATS

The location of anchorages for occupants of seats, which are adjustable or movable in the fore and aft direction and in which the belt passes outside of the seat or through, the seat cushions shall be as follows:

A line from the belt contact point to the belt angle reference point 2.50 inches (63.5 mm) forward of and 0.375 inches (9.5 mm) above the seating reference point (SRP) will form an angle as determined from the guidelines in paragraph 4.1 and as shown in Figure 1.

4.2.2 FIXED SEATS

The location of anchorages for occupants of fixed seats in which the belt passes outside the seat or through the seat springs shall be as follows:

A line from the belt contact point to the seating reference point (SRP) will form an angle as determined from the guidelines in paragraph 4.1 and as shown in Figure 2.

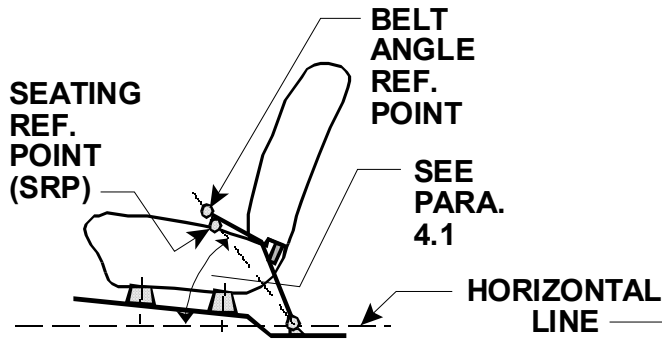

FIG. 1 - BELT OUTSIDE SEAT OR THROUGH SEAT SPRINGS SEAT CROSS BAR

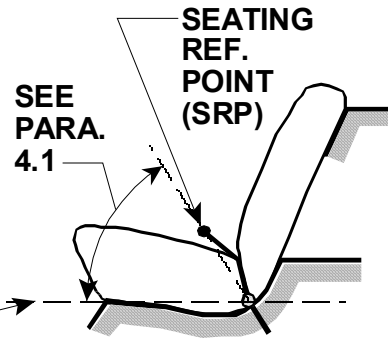

FIG. 2 - REAR SEAT BELT INSTALLATION

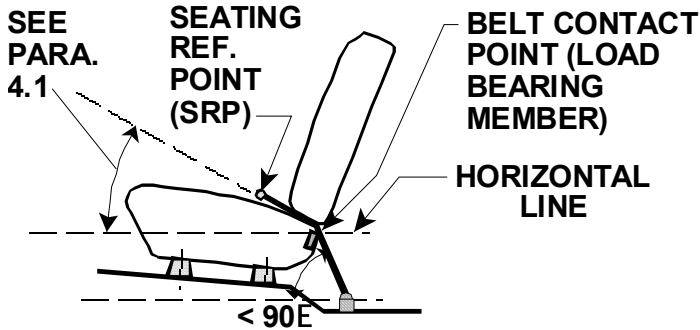

FIG. 3 - BELT OVER SEAT CROSS BAR

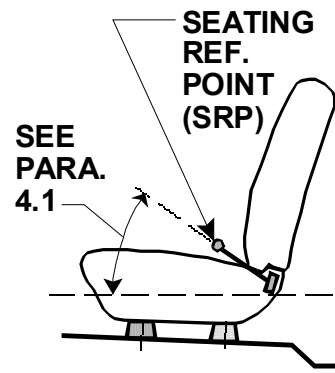

FIG. 4 - BELT ATTACHED TO SEAT FRAME

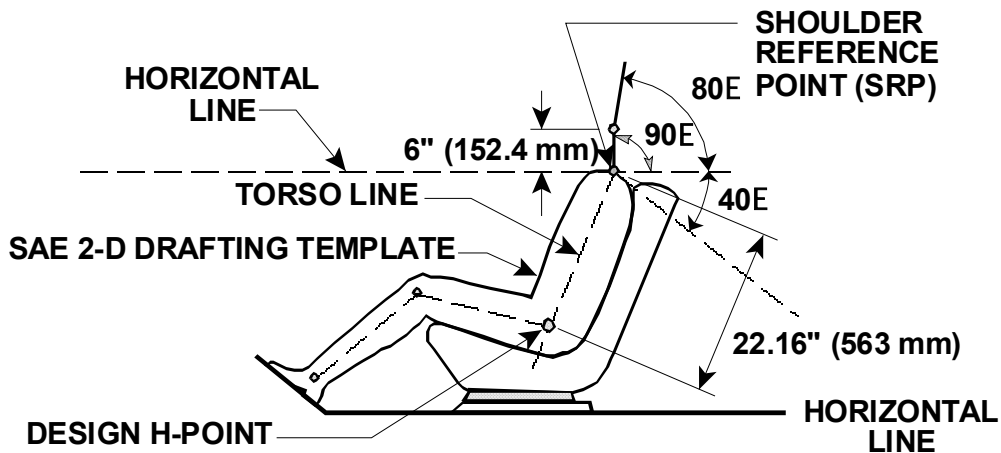

FIG. 5 - UPPER TORSO RESTRAINT

APPENDIX B...Continued

4.2.3 SEAT BELT ROUTING TO ANCHORAGE

In the side view where a direct belt routing is interrupted by intervening load bearing member (refer to Belt Contact Point definition in paragraph 2.6) the anchorage shall not be located forward of the rearmost point at which the webbing passes over that intervening member. Movable seats should be measured in the rearmost normal position. See Figure 3.

4.3 ANCHORAGES ON SEAT STRUCTURE FOR PELVIC RESTRAINT BELTS

The location of anchorages for occupants of seats in which the belts are anchored to seat structure shall be as follows:

A line from the belt contact point to the seating reference point (SRP) will form an angle as determined from the guidelines in paragraph 4.1 and as shown in Figure 4.

4.4 LATERAL LOCATION FOR ALL PELVIC RESTRAINT BELTS

Anchorage for any individual pelvic restraint belt assembly shall be located at least 6.5 inches (165.1 mm) apart and preferably shall be placed equidistant from the longitudinal centerline of the designated seating position (DSP) unless intervening load bearing members provide the spacing desired.

5. LOCATION OF UPPER TORSO RESTRAINT ANCHORAGES

5.1 SIDE VIEW LOCATION

With the seat in its full rearward and downward position and the seatback in its most upright design position, the upper anchorage(s) shall be longitudinally in line with, or rearward of, a line extending 6 inches (152.4 mm) vertically above the shoulder reference point (SRP) and then extending rearward at an angle of 80 degrees above the horizontal (see Figure 5). If there is a downward angle of the belt, passing from the shoulder reference point (SRP) to an anchorage or over suitable structure to an anchorage, this anchorage shall be (on or) above a line extending rearward and 40 degrees below the horizontal.

5.2 FRONT VIEW LOCATION

The upper torso restraint anchorage shall be positioned to minimize contact of the seat belt assembly with the neck and avoid it sliding off the shoulder of the occupant in a reasonably erect position.

APPENDIX B....Continued**6. CORROSION PROTECTION**

Design consideration shall be given to providing protection from corrosion for the seat belt anchorage(s) and the adjacent body structure. Special consideration shall be given to that portion or portions of the structure, which must sustain the anchorage test loads. The degree or type of protection required will be determined by the location of the anchorage(s) in the vehicle structure, the amount of exposure to corrosive elements, the configuration of the structure (if configuration may tend to induce corrosion). and the thickness of the supportive structure.