

[NHTSA notes: The Deputy Administrator has signed the following document and the Agency is submitting it for publication in the Federal Register. While NHTSA has taken steps to ensure the accuracy of this version of the document, it is not the official version. Please refer to the official version in a forthcoming Federal Register publication or on GPO's Web Site. You can access the Federal Register at <http://www.archives.gov/federal-register/index.html>]

DEPARTMENT OF TRANSPORTATION

National Highway Traffic Safety Administration

49 CFR Part 572

Docket No. NHTSA-2020-0088

RIN 2127-AL04

Anthropomorphic Test Devices;

Q3s 3-Year-Old Child Side Impact Test Dummy;

Incorporation by Reference

AGENCY: National Highway Traffic Safety Administration (NHTSA), Department of Transportation (DOT).

ACTION: Final rule.

SUMMARY: This final rule amends NHTSA's regulation on anthropomorphic test devices (ATD) (49 CFR Part 572) to add design and performance specifications for a test dummy representing a 3-year-old child, called the "Q3s" test dummy. The Q3s is an instrumented dummy that can assess the performance of child restraint systems in protecting small children in side impacts. Adding the Q3s to Part 572 provides NHTSA a new test device that can be used to improve side impact protection for children.

DATES: The effective date of this final rule is: **[INSERT DATE 60 DAYS AFTER DATE OF PUBLICATION IN THE FEDERAL REGISTER]**. The incorporation by reference of the

publications listed in the rule has been approved by the Director of the Federal Register as of **[INSERT DATE 60 DAYS AFTER DATE OF PUBLICATION IN THE FEDERAL REGISTER]**.

Petitions for reconsideration: Petitions for reconsideration of this final rule must be received not later than **[INSERT DATE 45 DAYS AFTER DATE OF PUBLICATION IN THE FEDERAL REGISTER]**. The petition will be placed in the docket. Anyone is able to search the electronic form of all documents received into any of the agency's dockets by the name of the individual submitting the comment (or signing the comment, if submitted on behalf of an association, business, labor union, etc.).

Privacy Act: In accordance with 5 U.S.C. 553(c), DOT solicits comments from the public to better inform its rulemaking process. DOT posts these comments, without edit, to www.regulations.gov, as described in the system of records notice, DOT/ALL-14 FDMS, accessible through www.dot.gov/privacy. In order to facilitate comment tracking and response, the agency encourages commenters to provide their name, or the name of their organization; however, submission of names is completely optional. Whether or not commenters identify themselves, all timely comments will be fully considered. If you wish to provide comments containing proprietary or confidential information, please see below.

Confidential Business Information: If you wish to submit any information under a claim of confidentiality, you should submit three copies of your complete submission, including the information you claim to be confidential business information, to the Chief Counsel, NHTSA, at the address given under FOR FURTHER INFORMATION CONTACT. In addition, you should submit a copy, from which you have deleted the claimed confidential business information, to Docket Management at the address given above. When you send a comment containing

information claimed to be confidential business information, you should include a cover letter setting forth the information specified in NHTSA's confidential business information regulation (49 CFR Part 512).

ADDRESSES: Petitions for reconsideration of this final rule must refer to the docket and regulatory information number (RIN) set forth above and be submitted to the Administrator, National Highway Traffic Safety Administration, 1200 New Jersey Avenue, S.E., Washington, D.C. 20590. Note that all petitions received will be posted without change to <http://www.regulations.gov>, including any personal information provided.

FOR FURTHER INFORMATION CONTACT:

For technical issues: Peter Martin, NHTSA Office of Crashworthiness Standards (telephone 202-366-5668) (fax 202-493-2990). *For legal issues:* Deirdre Fujita, NHTSA Office of Chief Counsel (telephone 202-366-2992) (fax 202-366-3820). Mailing address: National Highway Traffic Safety Administration, U.S. Department of Transportation, 1200 New Jersey Avenue, S.E., West Building, Washington, D.C. 20590.

SUPPLEMENTARY INFORMATION:

Table of Contents

I. Executive Summary

II. Background

- a. 2013 Part 572 NPRM and 2014 FMVSS No. 213 NPRM
- b. Comments on the 2013 Part 572 NPRM

III. Summary of Differences Between the NPRM and this Final Rule

- a. Acceptance Criteria for the Qualification Tests
- b. Qualification Test Procedures
- c. Engineering Drawings and the Procedures for Assembly, Disassembly, and Inspection (PADI)

IV. Response to Comments (Part I) on Developing the Regulation

- a. Copyright and Patent Issues
- b. Dummy Availability and Associated Data

- c. Developmental Stage of the Dummy
- d. Biofidelity
- e. Repeatability and Reproducibility (R&R)

V. Post-NPRM Test Program Overview

- a. Test Locations
- b. Other Data
- c. Component Tests in the Post-NPRM Test Program
- d. Controlling Variability

VI. Results of the Post-NPRM Test Program and the Final Acceptance Criteria for the Qualification Tests

- a. Background
- b. Process for Setting the Final Qualification Criteria
- c. Head
- d. Neck
- e. Lumbar Column
- f. Shoulder
- g. Thorax
- h. Pelvis

VII. Response to Comments (Part II) on the Dummy Qualifications and Test Procedures

- a. Head Qualification
- b. Neck Qualification
- c. Arm Position

VIII. Post-NPRM Data from Humanetics

- a. Qualification Tests
- b. Mass and Anthropometry Measurements

IX. Drawing Package and PADI

X. Other Issues

- a. Durability
- b. Consideration of Alternatives

XI. Rulemaking Analyses and Notices

I. Executive Summary

This final rule amends NHTSA's regulation on anthropomorphic test devices (49 CFR Part 572) by adding a new Subpart W that sets forth design and performance specifications and qualification tests for a test dummy representing a 3-year-old child, called the Q3s test dummy.

The Q3s is an instrumented dummy that can assess the performance of child restraint systems in protecting small children in side impacts. The Q3s weighs 14.5 kilograms (kg) (32.0 pounds) and has a seated height of 556 millimeters (mm), and is representative of a 50th percentile 3-year-old child. The Q3s dummy's main parts (head, thorax, neck, shoulder, spine, abdomen, pelvis, and relevant instrumentation) and biofidelity are described in detail in a November 21, 2013 notice of proposed rulemaking (NPRM) preceding this final rule (78 FR 69944, 69946). NHTSA plans to use the Q3s test dummy in a proposed side impact test for child restraints.¹

This final rule incorporating the Q3s into 49 CFR Part 572 standardizes NHTSA's specifications on the dummy for testing and research purposes. Subpart W specifies a set of qualification tests and acceptance criteria for the Q3s's head, neck, shoulder, thorax, lumbar, and pelvis, assessing 35 response mechanisms for the dummy.² Additionally, Subpart W incorporates by reference a technical data package (TDP) for the Q3s consisting of a set of engineering drawings, a parts list, and a user's manual that has procedures for assembly, disassembly, and inspection (PADI) of the dummy.³ Q3s dummies manufactured to meet the acceptance criteria for the qualification tests and the TDP will be uniform in their design, construction, and response to impact forces.

¹ NPRM to amend Federal Motor Vehicle Safety Standard (FMVSS) No. 213, "Child restraint systems," January 28, 2014, 79 FR 4570.

² Test dummies specified in 49 CFR Part 572 are subjected to a series of tests, called "qualification tests," to ensure that their components are functioning properly. Conformity to the acceptance criteria for the qualification tests qualify the dummy as an objective and suitable test device for the assessment of occupant safety in compliance tests specified in the FMVSSs. Conformity assures that the dummy can respond properly in the compliance test, while non-conformance indicates the need for adjustment, repair or replacement. Qualification tests also monitor the response of components that may tend to deteriorate over time. For each test, certain dummy sensors and signal characteristics (such as the magnitude and timing) have been specified as qualification targets. By monitoring these sensors, the qualification tests assure that the dummy is functioning properly. Loose or damaged dummy hardware is often manifested in a signal that does not conform to the qualification targets, thus indicating that dummy maintenance may be needed. Conformity also assures that the sensors themselves are working properly.

³ The parts list, engineering drawings, and the PADI for the Q3s are available for examination in the docket for this final rule.

As discussed in the November 21, 2013 NPRM, the Q3s was found to exhibit repeatable performance in CRS side impact sled testing and in component-level qualification testing. However, NHTSA acknowledged in the NPRM that the agency's findings in the proposed rule were based on only a few Q3s dummies then in existence. At the time of publication of the NPRM, the Q3s was a proprietary product owned by Humanetics Innovative Solutions Inc. (HIS), and HIS was the only source from which to obtain the dummy. NHTSA developed the Q3s NPRM based on NHTSA's testing experiences with four units that the agency had purchased from HIS. In the NPRM, the agency expressed a desire to examine more data on more dummies from multiple test labs and an expectation that it will "continue to collect qualification data" and "will examine all qualification data provided to us by commenters." 78 FR at 69959.

NHTSA received comments on the Q3s NPRM from the Juvenile Products Manufacturers Association (JPMA), Graco Children's Products, Inc. (Graco), Dorel Juvenile Group (Dorel), and HIS. Several commenters said they could not obtain the Q3s dummies from the dummy manufacturer HIS and so had little or no information about the ATD. Some expressed concern that the dummy's repeatability and reproducibility of performance were not assessed across various test facilities. Some asked for more data from tests with more dummies to round out the qualification corridors. In addition, the commenters made several technical comments relating to the ATD .

Subsequently, in mid-2014, HIS began delivery of new Q3s dummies to end-users that included NHTSA, CRS manufacturers, and testing laboratories. In 2014 and 2015, to obtain more data on the Q3s, NHTSA undertook systematic testing of the new units from HIS, contracting with laboratories to carry out a full series of qualification tests with six Q3s

dummies. The units included three of the agency's original four dummies together with new dummies manufactured in 2014.

The agency set up a series of experiments designed to evaluate the performance of the Q3s in several different labs, examining the repeatability and reproducibility of the Q3s's performance. NHTSA designed the test program to assess all sources of variability, to quantify the degree of variability, determine its acceptability, and assess whether the underlying cause was a non-uniform test procedure at a lab (and among the labs), an aspect of dummy design, or the dummy manufacturer's production of Q3s units. Data from the tests were used to finalize the acceptance criteria for the qualification tests and ensure that a high level of repeatability and reproducibility (R&R) will be maintained henceforth.⁴

For this final rule, HIS has removed all proprietary rights to the Q3s. Single-source restrictions were in place during the NPRM stage (HIS retained rights to manufacture the dummy). However, the dummy drawings and designs are now free of any restrictions. This includes restrictions on their use in fabrication and in building computer simulation models of the dummy.

Benefits and Costs

The benefits associated with this rulemaking cannot be quantified. The incorporation of the test dummy into 49 CFR Part 572, the first-ever child test dummy incorporated by NHTSA for use in side impacts, has the potential to significantly improve child passenger safety in motor vehicles. Adopting the Q3s gives NHTSA a tool to assess the performance of dynamic side impact protection requirements for child restraints using an ATD representative of children for

⁴ The additional data also led to NHTSA's making some technical modifications to the proposed Part 572 specifications, i.e., NHTSA removed the requirement for the pubic load in the pelvis impact test, revised aspects of the neck and lumbar tests, and corrected some of the drawings for the dummy. The agency discusses and lists the technical changes from the NPRM to this final rule below in this preamble.

whom the CRS is designed, and quantitatively evaluate the effectiveness of CRSs in preventing or attenuating head and chest impacts in side impacts. In addition, the availability of this dummy in a regulated format will provide a test tool that can potentially be used with other products designed to benefit children in side impacts.

This final rule does not impose any requirements on anyone. NHTSA has proposed to use the Q3s in its compliance testing of the FMVSS No. 213 test under development, but even following adoption of the test, manufacturers would not be required to use the Q3s or assess the performance of their products in the manner specified in the standard. Child restraint manufacturers would be affected by this final rule only if they choose to use the Q3s to test their products.

For entities choosing to own the Q3s, NHTSA estimates that the estimated cost of an uninstrumented Q3s dummy is approximately \$50,000. Instrumentation installed within the dummy needed to perform the qualification in accordance with Part 572 Subpart W adds approximately \$20,000, for a total cost of about \$70,000.

Summary of Decision

The data presented in the 2013 NPRM and obtained in NHTSA's post-NPRM test program demonstrate that the Q3s is a valuable tool for use in side impact testing. Adopting the Q3s into 49 CFR Part 572 enhances NHTSA's efforts to reduce unreasonable risks posed by side crashes to children.

II. Background

a. 2013 Part 572 NPRM and 2014 FMVSS No. 213 NPRM

On November 21, 2013, NHTSA published an NPRM proposing design and performance specifications and qualification tests for the Q3s, a new test dummy representative

of a 3-year-old child for use in side impact testing (78 FR 69944). On January 28, 2014, NHTSA published an NPRM proposing to amend FMVSS No. 213 to add a new side impact test in which the Q3s would be used. The proposed side impact test applies to CRSs designed for children weighing up to 18 kg (40 pounds) (79 FR 4570). The proposal responds to a statutory mandate in the “Moving Ahead for Progress in the 21st Century Act” (MAP-21),⁵ that NHTSA “issue a final rule amending Federal Motor Vehicle Safety Standard Number 213 to improve the protection of children seated in child restraint systems during side impact crashes.” These two NPRMs are referred to herein as the Part 572 NPRM and the FMVSS No. 213 NPRM, respectively.

b. Comments on the 2013 Part 572 NPRM

NHTSA received comments on the Part 572 NPRM from HIS, Graco Children’s Products, Inc. (Graco), Dorel Juvenile Group, Inc. (Dorel), and the Juvenile Products Manufacturers Association (JPMA). Some of the comments on the FMVSS No. 213 NPRM discussed subjects pertaining to the Part 572 NPRM, which NHTSA discusses in this document as appropriate. The commenters on the FMVSS No. 213 NPRM include Evenflo Company, Inc. (Evenflo), Britax Child Safety, Inc. (Britax), Consumers Union, Advocates for Highway and Auto Safety (Advocates), and Transport Research Laboratory, U.K. (TRL).

Commenters on the Part 572 NPRM discussed issues related to the following main areas: single source and patents; dummy and qualification data availability, biofidelity; repeatability and reproducibility of results (R&R); qualification test corridors, drawing errors; and test procedure protocols. These issues and NHTSA’s responses to the comments are discussed below in this preamble.

⁵ Section 31501(a) of Subtitle E, “Child Safety Standards,” of MAP-21 (July 6, 2012) (P.L. 112-141).

III. Summary of Differences Between the NPRM and this Final Rule

a. Acceptance Criteria for the Qualification Tests

A comparison of the acceptance criteria for the qualification tests (or “qualification limits”) in the NPRM versus the final rule is summarized in Table 1. All changes from the NPRM are discussed below in this preamble. The velocities and acceleration pulses of the impacting pendulums, which ensure that qualification test conditions are uniform, are unchanged from the NPRM.

Table 1. Q3s Qualification Limits (NPRM vs. Final Rule)

Test	Measurement	units	NPRM	Final Rule
Head – Frontal	Resultant acceleration	G	250 – 297	255 - 300
	Off-axis acceleration (Ay)	G	- 20 to +20	- 15 to +15
Head – Lateral	Resultant acceleration	G	113 – 140	114 – 140
	Off-axis acceleration (Ax)	G	- 20 to +20	- 15 to +15
Neck – Flexion	Maximum rotation	deg	70 – 82	69.5 – 81.0
	Time of max rotation	msec	55 – 63	no req.
	Peak moment (My)	N-m	41 – 51	41.5 – 50.7
	Time of peak My	msec	49 – 62	note 1
	Decay time to 0 from peak angle	msec	50 – 54	45 – 55
Neck – Lateral	Maximum rotation	deg	77 – 88	76.5 – 87.5
	Time of max rotation	msec	65 – 72	no req.
	Peak moment (Mx)	N-m	25 – 32	25.3 – 32.0
	Time of peak Mx	msec	66 – 73	note 1
	Decay time to 0 from peak angle	msec	63 – 69	61 – 71
Neck – Torsion	Maximum rotation	deg	75 – 93	74.5 – 91.0
	Time of max rotation	msec	91 – 113	no req.
	Peak moment (Mz)	N-m	8 – 10	8.0 – 10.0
	Time of peak Mz	msec	85 – 105	note 1
	Decay time to 0 from peak angle	msec	84 – 103	85 – 102
Shoulder	Lateral displacement	mm	16 – 21	17.0 – 22.0
	Peak probe force	N	1240 - 1350	1123 - 1437
Thorax with Arm	Lateral displacement	mm	23 – 28	22.5 – 27.5
	Peak probe force	N	1380 – 1690	1360 – 1695
	Lateral displacement	mm	24 – 31	24.5 – 30.5

Thorax without Arm	Peak probe force	N	620 – 770	610 – 754
Lumbar – Flexion	Maximum rotation	deg	48 – 57	47.0 – 58.5
	Time of max rotation	msec	52 – 59	no req.
	Peak moment (My)	N-m	78 – 94	78.2 – 96.2
	Time of peak My	msec	46 – 57	note 1
	Decay time to 0 from peak angle	msec	50 – 56	49 – 59
Lumbar – Lateral	Maximum rotation	deg	47 – 59	46.1 – 58.2
	Time of max rotation	msec	50 – 59	no req.
	Peak moment (Mx)	N-m	78 – 97	79.4 – 98.1
	Time of peak Mx	msec	46 – 57	note 1
	Decay time to 0 from peak angle	msec	47 – 59	48 – 59
Pelvis	Peak pubic load	N	700 – 870	no req.
	Peak probe force	N	1570 – 1810	1587 – 1901

¹Maximum moment occurs during the time interval while the rotation is within the specified interval.

b. Qualification Test Procedures

The agency made a few adjustments to the proposed qualification test procedures, which are summarized in Table 2 below. (Noteworthy changes are discussed in this preamble.) For simplicity, the English units that were shown in parentheses in the regulatory text of the NPRM are omitted. The qualification tests themselves are essentially unchanged from the NPRM.⁶

Table 2. Summary of revisions to procedures

Reg. text affected section	Description of change
§572.212(c)(1) Head drop test	Ambient temp. now 20.6-22.2 deg C
§572.213(c)(1)(i) Neck flexion test §572.213(c)(2)(i) Neck lateral flexion test §572.213(c)(3)(i) Neck torsion test §572.217(c)(1)(i) Lumbar flexion test §572.217(c)(2)(i) Lumbar lateral flexion test	Maximum moment now occurs when rotation is within the specified range.
§572.213(b)(3)(ii) Neck torsion test	Correction on time = 0 definition.

⁶ The qualification tests have proven reliable and sound in qualifying the Q3s throughout the dummy's developmental stages and in qualifying virtually all other test dummies specified in Part 572.

§572.213(c)(2)(ii) Neck lateral flexion test §572.217(c)(2)(ii) Lumbar lateral flexion test	Correction on specifying left vs. right mirroring in test setup figures.
§572.214(c)(4) Shoulder test §572.215(c)(4) Thorax with arm tests	New steps to position arm against thorax.
§572.218(a) Pelvis assembly and test procedure §572.219 Test conditions and instrumentation	Pubic load cell now optional since pubic criterion has been omitted.
§572.212(c)(4) Head drop test, Figures W1, W2	Surface finish: 0.2-2.0 microns RMS.
§572.212(c)(2)(ii) Lumbar lateral flexion test	Headform sagittal plane perpendicular (not parallel) to the motion of the pendulum.
Figures W6, W7, W8, W11	Correction on probe mass: now 3.81 kg.
Throughout regulatory text	English units omitted.

This final rule also corrects the following errors. The surface finish of the steel plate used in the head qualification test was not specified correctly in the NPRM. The correct specification is 0.2-2.0 microns root mean square (RMS). In the lateral lumbar qualification test, the proposed regulatory text was unclear in how it described the orientation of the headform, so it has been clarified. In Figures W6, W7, W8, and W11 of the proposed regulatory text, the probe mass was labeled incorrectly as 3.85 kg. The correct value is 3.81 kg.

c. Engineering Drawings and the Procedures for Assembly, Disassembly, and Inspection (PADI)

For this final rule, NHTSA has revised some of the engineering drawings to address discrepancies between the PADI and the engineering drawings, and some inconsistencies HIS noticed between the drawings it provided NHTSA for development of the NPRM and the dummies HIS produced. The changes are all valued-added revisions that either correct errors or provide missing information. They are not alterations that would change the dummy in any meaningful way or alter the dummy's response in either pre-test qualification testing or dynamic

sled testing with CRSs. The changes to the drawings and the PADI are discussed in detail in Section IX below. A comprehensive listing of changes is described in the document, “Q3s Engineering Drawing Changes, Rev. J, May 2016.”⁷ The design of the Q3s is essentially unchanged.

IV. Response to Comments (Part I) on Developing the Regulation

a. Copyright and Patent Issues

HIS had certain property rights in the Q3s engineering drawings during the notice and comment period of this rulemaking. As discussed in the NPRM (78 FR at 69965-69966), during the notice and comment period, the Q3s engineering drawings used to fabricate the dummy were available in the docket for public review and comment, but most displayed the HIS name in the title block with a note restricting copying of or using the drawings other than for commenting purposes. NHTSA stated in the NPRM that the name, note, and all restrictions associated with the drawings will be removed at the final rule stage. Separately, in the NPRM, NHTSA noted its awareness that a patent application filed by HIS may cover certain parts of the Q3s dummy.

Comments Received

NHTSA received several comments expressing concern about the intellectual property restrictions on the dummy. JPMA and Dorel expressed concern that manufacturers will be bound to purchase a single-sourced dummy that is subject to patents and unregulated price points.

NHTSA Response

The Q3s specified in this final rule is free of any known copyright or patent restrictions.

⁷ This document can be found in the docket for this final rule.

Although copyright restrictions were in place during the NPRM stage for the Q3s engineering drawings, all restrictions are removed for this final rule. The HIS name and the copyright note have been removed from all of the drawings. The dummy drawings are free of any restrictions and can be used in dummy fabrication and in building computer simulation models of the dummy. Moreover, there are no patents associated with the Q3s adopted by this final rule.⁸

b. Dummy Availability and Associated Data

The difficulty in obtaining the Q3s was brought up in comments to both the Part 572 and the FMVSS No. 213 NPRMs by several commenters. JPMA indicated it was not possible to learn of the strengths and limitations of the Q3s, particularly regarding its repeatability, reproducibility, and reliability. Graco, Britax and Evenflo indicated that the lack of availability of the dummy to the CRS industry and outside test facilities has prevented a more complete evaluation of the dummy across various test facilities and multiple CRS manufacturers. Dorel and HIS commented that more data from more dummies are needed to round out the qualification corridors.

NHTSA Response

It is true that the Q3s was generally unavailable from HIS during the original comment period which ended April 28, 2014. Because of that unavailability, on June 4, 2014, NHTSA reopened the comment period for the FMVSS No. 213 NPRM, granting a petition from JPMA (79 FR 32211). NHTSA agreed at that time to reopen the comment period until October 2, 2014, because the Q3s was slated to become widely available from HIS to CRS manufacturers around

⁸ The patent issue was discussed in the NPRM (78 FR at 69965). Around the time of the NPRM, NHTSA became aware that HIS had filed a patent application with the United States Patent and Trademark Office potentially covering certain parts of the Q3s dummy. However, the patent eventually issued – for a rib cage incorporating a polyurethane material with a type of metal insert – is not used in the current design. (See U.S. Patent No. 8,840,404 B2, “Rib cage for assembly for crash test dummy,” September 23, 2014.) Accordingly, the patent does not apply to the version of the Q3s specified in this final rule.

mid-2014.⁹ Since mid-2014, the dummy has been available, as HIS has filled many orders for the Q3s since then.

Regarding the qualification corridors, NHTSA concurs that development of qualification corridors is benefitted when more data are available on the ATD's performance in the qualification tests. In the NPRM for this final rule (78 FR 69959), the agency acknowledged that there was a limited amount of qualification data available to NHTSA for use in setting the proposed qualification limits.¹⁰ NHTSA stated in the NPRM that the agency expected to receive qualification data from end-user commenters on the dummies tested at their own laboratories, and that, with those data, the agency would adjust the qualification limits to account for a greater population of dummies, and modify the test procedures as needed.¹¹

When data from users were not forthcoming because of the unavailability of the Q3s, NHTSA designed a test program to obtain the desired data once the dummy became available. In mid-2014, NHTSA borrowed three new Q3s units from existing owners (manufactured by HIS and delivered to end-users in mid-2014) to collect comparative qualification data with their new units. The agency systematically tested the three new units, as well as three of the agency's older units (manufactured in 2012 or before and used to develop the 2013 Part 572 NPRM). NHTSA hired test labs to carry out a full series of qualification tests with the six Q3s dummies.

⁹ Graco apparently was able to obtain and assess a new Q3s unit during the reopened comment period. In a comment on the FMVSS No. 213 NPRM, Graco states that it "supports the use of the Q3s ATD for side impact testing based on NHTSA's data and confirmed structural performance during the developmental testing period. Graco has been using the Q3s in our internal lab for about 6 months and we are satisfied with the overall performance of the ATD." "Feedback Document for FMVSS 213 Side Impact [NPRM], Oct. 1, 2014, p.10.

¹⁰ For the NPRM, NHTSA established qualification requirements based on replicate trials conducted sequentially on the four NHTSA-owned Q3s units at VRTC. These tests were used to set the upper and lower limits of the qualification corridors. They were initially set as follows: either ± 3 standard deviations from the mean or ten percent from the mean, whichever was narrower. Upper and lower bounds were then rounded to the next whole number away from the mean using three significant digits such that the final bounds were slightly wider than the initial bounds. NHTSA expected to refine and narrow the corridors when additional data was received on other Q3s units.

¹¹ The adjustments made to the limits and procedures are listed Tables 1 and 2, *supra*.

The agency's design of experiments allowed NHTSA to assess the reproducibility and repeatability of the dummy and sort out sources of variability. NHTSA examined variability due to any non-uniform test procedure at each lab (and among the labs), variability in the dummy design, and variability in HIS's production of multiple Q3s units. Using this systematic process, NHTSA compiled the additional test data, and those submitted by other end-users, to set the acceptance criteria for the qualification tests for the Q3s. The post-NPRM test program is discussed at length in this preamble in Sections V and VI.

c. Developmental Stage of the Dummy

Comment Received

The NPRM referred to the Q3s as the "build level D" iteration of the dummy (Build D). "Build level" is a term used by HIS to describe a specific revision level of the dummy relative to previous versions it sold. The Q3s drawings that HIS provided NHTSA prior to the publication of the NPRM were marked as revision level D.¹²

In its comment, HIS states that it considers the build level D dummy to be out of date, and that the dummy specified in a final rule should be referred to as "Build E." HIS states that not using the "Build E" designation could cause hardship to its customers who might not know which version of the dummy they own, or who might erroneously assume that their build level D dummy is up to date when in fact the ATD "may be missing key updates."

NHTSA Response

For the reasons set forth below, NHTSA declines to make the change. NHTSA does not believe that using the HIS naming conventions for this final rule is necessary or warranted. For

¹² In the TDP drawings placed in the NPRM docket, the HIS build level that HIS identified for the ATD is reflected in the top level assembly drawing of the Q3s, 020-0100 (sheet 1). This drawing shows that HIS marked revision level D in the title block.

the final rule, the agency has adopted a drawing package that has been periodically fine-tuned since publication of the NPRM in 2013 (discussed in sections below), so the revision level of the Technical Data Package had been updated from Revision (Rev.) D to Rev. J. We do not believe that NHTSA has to name the Q3s “Build E” to enable HIS to notify customers who bought Build D units built between December 2010 and November 2013 that their units may be missing key updates. HIS can use its sales records and customer outreach to determine which Q3s units its customers bought and which need updating. With those records and outreach, HIS can determine the type of conversion needed to bring the units up to date and facilitate their customers’ updates of the previously-purchased ATDs.

Comment Received

Dorel believed that many aspects of the Q3s, such as the fixture used to run the neck torsion qualification tests, were not fully engineered, and are thus not finalized and ready for sale. Dorel also cited unavailability of specialized Q3s signal processing software as a hold-up to its dummy evaluation.

NHTSA Response

Dorel is mistaken in believing that the Q3s and its complementary fixtures used in qualification testing were not fully engineered. The NPRM for the Q3s provided all the information needed to assess the dummy in qualification tests, including complete engineering drawings of the neck torsion fixture. The neck torsion fixtures were not rights-protected in the NPRM for the Q3s. The agency knows of at least two other labs in addition to the agency’s Vehicle Research and Test Center (VRTC) that have built them on their own (MGA Research Corporation (MGA)) and Calspan).

With regard to Dorel's software concern, NHTSA has not developed specific software for the express purpose of processing qualification data for the Q3s or any other dummy. NHTSA does not provide software that would fully automate the processing of raw signals to determine the PASS/FAIL outcomes in each of the eleven Q3s qualification tests. Such software is a third-party product. As with all Part 572 regulations, NHTSA specifies the test procedures, the test equipment, the instrumentation, and the filter frequencies of the test signals. The means to process the signals (in accordance with the Part 572 specifications) is left to the discretion of each test lab.

NHTSA does maintain a library of software tools that aid in the processing of raw signal data.¹³ This includes a collection of Microsoft Windows graphical applications for analysis and processing of signal data. Core algorithms in this package include minimum/maximum applications, signal scaling, numerical integration, and digital filtering as specified by many FMVSS and Part 572 standards (including Subpart W for the Q3s.) These tools may be used to process data generated in Q3s qualification tests.

d. Biofidelity

The Part 572 NPRM discussed NHTSA's findings that the Q3s is suitably biofidelic overall and especially in the head, thorax and neck which are the body segments most critical for the intended use of the dummy in side impact testing. (78 FR at 69947-69950.)

Comment Received

In its comment, JPMA stated its belief that the Q3s's biofidelity is not representative of a 3-year-old, living child. JPMA stated¹⁴—

¹³ <http://www.nhtsa.gov/Research/Databases+and+Software>.

¹⁴ See Docket NHTSA-2013-0118-0008, page 2.

As the agency is aware, its assessment of the Q3s focused on (1) a scaled-down version of post mortem adult human subject data, and (2) cadaver testing under dynamic loading. Unfortunately, the scaled-down adult data presumes incorrectly that adults and children are the same internally, which is simply not the case. For example, children's bones and bodies in general are much more flexible than their adult counterparts. Merely scaling adult data on the basis of mass, geometric and stiffness ratios will not represent accurate child-centered data. Therefore, while appropriate in size and weight to a live 3-year-old, the Q3s is not representative of live, reactive 3-year-old children. Due to the known differences between the Q3s and the children the ATD is supposed to represent, the developing side impact test standard carries with it a certain level of inherent risk — that child restraints built to comply with the new standard will be moving away from real-world effectiveness.

NHTSA Response

NHTSA's biofidelity assessment of the Q3s (provided in a report in the docket for the NPRM¹⁵) compared the responses of the dummy to targets previously established for a three-year-old child. The targets themselves were published in a Stapp Journal article by the SAE Hybrid III Dummy Family Task Group.¹⁶

For ethical reasons, biomechanical response data on children under impact loading are very limited. Therefore, scaling techniques are necessary to derive the child impact response targets from laboratory tests on adult post-mortem human subjects (PMHS).¹⁷

The SAE scaling procedure followed an impulse-momentum approach to derive response targets for a three-year-old from targets established previously for adults. The procedure made use of adult-to-child ratios of mass, anthropometry, and bone stiffness. In its comments, JPMA implied that this procedure does not account for differences in bone flexibility between adults and children. This is not the case. Differences in bone flexibility are integral to the scaling

¹⁵ See Docket NHTSA-2013-0118, "Biofidelity Assessment of the Q3s Three Year-Old Child Side Impact Dummy," July 2012.

¹⁶ Irwin AL, Mertz HJ, Elhagediab AM, Moss S (2002). Guidelines for Assessing Biofidelity of Side Impact Dummies of Various Sizes and Ages. Stapp Car Crash Journal V46: 297-319, SAE International, Warrendale, PA.

¹⁷ Aside from its response to impact, the size and shape of the Q3s is based on child anthropometry. The size and shape of the ATD is not scaled from an adult model or other dummy size.

process, which employs adult-to-child bone stiffness ratios. For three-year-old vs. adult scaling, a bone stiffness ratio of 0.475 was applied. This ratio was derived using measurements of the elastic modulus of human bone samples from actual children as explained in the Stapp article. The scaling ratios were all applied to a lumped mass and spring model to arrive at biomechanical corridors for a three-year-old. Stated differently, the scaling theory used to establish the impact response of a human three-year-old does account for differences in flexibility and stiffness between adults and children.

Details on the derivation of the scaling model and its application may be found in Mertz (1984)¹⁸ and Mertz, et al. (1989).¹⁹ NHTSA notes that the impulse-momentum approach was used for other Part 572 child dummies, including the CRABI infant dummy²⁰ and the Hybrid III family of child dummies.^{21, 22} Thus, the biomechanical targets used to assess the Q3s were derived the same way as the targets for all other child dummies. Given the limitations on pediatric data, NHTSA believes the scaling process represents an appropriate, best available method of estimating the living, human child's response characteristics.

To summarize, NHTSA believes that the scaling process used to derive biomechanical response targets for the Q3s is well-founded and reasonable. The scaling process does not presume that adults and children are the same internally. The process assumes that the response

¹⁸ Mertz HJ (1984), "A procedure for normalizing impact response data," Paper No. SAE 840884, Biomechanics of Impact Injury and Injury Tolerances of the Thorax-Shoulder Complex - PT-45, SAE International, Warrendale, PA.

¹⁹ Mertz HJ, Irwin AL, Melvin JW, Stalnaker RL, Beebe MS (1989), "Size, weight, and biomechanical impact response requirements for adult size small female and large dummies," Paper No. SAE 890756, Automotive Frontal Impacts, SP-782, pp 133-144, SAE International, Warrendale PA.

²⁰ Melvin JW (1995), "Injury assessment reference values for the CRABI 6-month infant dummy in a rear-facing infant restraint with airbag deployment," Paper No. SAE 950872, SAE Congress and Exposition, Detroit, pp 1-12, SAE International, Warrendale PA.

²¹ Kleinberger M, Yoganandan N, Kumaresan S (1998), "Biomechanical considerations for child occupant protection," 42nd Annual Proceedings for the Association for the Advancement of Automotive Medicine, pp 115-136, Charlottesville, VA.

²² Mertz HJ, Jarrett K, Moss S, Salloum M, Zhao Y (2001), "The Hybrid III 10-year-old dummy," Paper No. 2001-22-0014, Stapp Car Crash Journal, V45, SAE International, Warrendale, PA.

of the targeted subject depends on its internal stiffness, and that internal stiffness varies by the age of the subject. The agency is satisfied with the overall biofidelity of the Q3s and is convinced that CRSs built to comply with the new side impact standard using the Q3s will be effective in the real world.

Q3s Shoulder

NHTSA evaluated the biofidelity of the Q3s shoulder in component testing under the loading of a pendulum. In the NPRM, NHTSA described an “unpadded” test conducted involving an SAE International protocol (Irwin, 2002) that uses a rigid pendulum in a pure lateral direction. In the test, the Q3s shoulder showed high stiffness with respect to lateral shoulder displacement and probe force under this test protocol. NHTSA later reexamined shoulder biofidelity under “padded” conditions that the agency believed corresponded more closely to the planned use of the Q3s in the proposed FMVSS No. 213 test than the unpadded condition. In the latter test, NHTSA used the Ohio State protocol (Bolte et al., 2003), which utilizes the same impactor mass and speed as the SAE International test but with foam padding attached to the impactor face. NHTSA determined that the latter condition was particularly relevant because the Q3s would most likely be exposed to a padded side structure (“wing”) of the child restraint in the test.²³ The striking surface, like the probe in the Ohio State test, would be padded.

Under the Ohio State protocol, the shoulder of the Q3s was also stiff when assessed for biofidelity as measured by its deflection (about 10 mm below the nominal biofidelity target). However, NHTSA found that the magnitude of the force applied by the padded probe (about 400 N) was well within the upper and lower limits of biofidelity. Therefore, NHTSA believed that the Q3s’s shoulder loading of the child restraint, which could affect the overall motion of the

²³ CRSs subject to a side impact test would likely use padded side wings as one of the main countermeasures to meet side impact protection requirements.

dummy's upper torso and head (relevant for the measurement of injury criteria under consideration), was representative of an actual human. (78 FR at 69949-69950.)

Comment Received

JPMA commented that it believed the shoulder of the Q3s is too stiff relative to a human child. The commenter stated that, because the shoulder is too stiff, the trajectory of the head during a compliance test will be unrealistic such that it could register artificially high HIC values. JPMA asserted that child restraint designs will thus need to be ultra-conservative in their ability to keep HIC low, and that this, in turn, could necessitate a seat design that is uncomfortable for children. JPMA was concerned that, to get comfortable, children may take on seating postures that could ultimately put the child at higher risk than when seated in a current CRS (i.e., one that is not designed to meet a new side impact requirement). The commenter did not provide any data or analysis supporting these views.

NHTSA Response

It is important to highlight the point made in the NPRM that, under conditions that correspond closest to the intended use of the Q3s in the proposed FMVSS No. 213 side impact test (i.e., using a foam-covered probe that is more akin to the shoulder interaction with a CRS “wing”), the force response of the padded probe (external biofidelity²⁴) nearly matches the target.²⁵ With the magnitude of the force generated by the padded probe well within the envelope for a biofidelic response, these data show that the Q3s shoulder is biofidelic in the

²⁴ For pendulum impacts, biofidelity is generally assessed as “external” or “internal.” External biofidelity is related to the force generated on the face of a pendulum impact probe upon striking a subject. In other words, probe forces generated by dummies are compared against probe forces generated by PMHS. Internal biofidelity is related to a measurement on or within the subject itself, such as shoulder deflection or spine acceleration, for which corresponding measurements are made on both the PMHS and the test dummy.

²⁵ 78 FR at 69949. “Biofidelity Assessment of the Q3s Three-Year-Old Child Side Impact Dummy,” July 2012, Docket No. NHTSA-2013-0118.

manner in which it will exert force on the CRS. Thus, this loading of the child restraint, which would affect the overall motion of the dummy's upper torso and head (through which the FMVSS No. 213 injury criteria under consideration would be measured), is representative of an actual human. JPMA did not provide any analysis or rationale supporting its conclusions that the Q3s shoulder will cause artificially high HIC values and that uncomfortable seat designs will result. Given all available data and information about the test dummy, NHTSA is satisfied with the biofidelity of the Q3s shoulder and how the ATD's shoulder, head and torso will interact when the dummy is restrained in a child restraint in the side impact test.

e. Repeatability and Reproducibility (R&R)

A test dummy's R&R may be assessed in sled tests and component tests.

“Repeatability” is defined here as the similarity of responses from a single dummy when subjected to multiple repeats of a given test condition. “Reproducibility” is defined as the similarity of test responses from multiple dummies when subjected to multiple repeats of a given test condition. Sled tests establish the consistency of the dummy's kinematics, its impact response as an assembly, and the integrity of the dummy's structure and instrumentation under controlled and representative crash test conditions. In component tests, the test conditions as well as the test equipment are carefully controlled to assure the dummy is subjected to a tightly controlled impulse and to minimize external effects on the dummy's responses.

Assessment of R&R

NHTSA's assessment of R&R was based on a statistical analysis of variance. The percent coefficient of variation (CV) is a measure of variability expressed as a percentage of the mean. The CV is calculated as follows:

$$CV = \frac{\sigma}{X} \times 10\%$$

where σ = standard deviation of responses²⁶
 \bar{X} = mean of responses

NHTSA has used CVs to assess the repeatability and reproducibility of ATDs throughout the history of Part 572, starting in 1975.²⁷ Separate CVs for repeatability and reproducibility, by labs and by dummies, were computed. The CVs were used to assess the degree to which the current population of Q3s dummies were able to attain targeted responses. In the NPRM, we described how provisional upper and lower limits for all qualification requirements were set at a maximum of 10% (before rounding) from a nominal response target. For any particular requirement, the 10% condition was always met in our post-NPRM testing when the CVs were all below 5% for repeatability and 6% for reproducibility. Under these circumstances, there is a high degree of uniformity in the construction of the dummy components being tested and in the procedures followed by the labs for that test requirement.

For example, in the post-NPRM test series for neck flexion, neck moments from 81 trials were recorded. In all 81 trials, the neck moment was well within 10% of the nominal target and the CVs were all below 5% for repeatability and below 6% for reproducibility. Thus, in our post-NPRM assessments, when the CVs for a particular test condition were below 5% and 6% for repeatability and reproducibility, respectively, no further examination of the data or test condition was carried out.

On the other hand, when a test condition produced a CV above 5% for repeatability or 6% for reproducibility, a response in at least one trial was usually beyond 10% of the nominal target. When a CV exceeded 10%, several trials were beyond 10% of the target. In these

²⁶ Standard deviations are based on a sample and calculated using the “n-1” method.

²⁷ See NPRM for the original subpart B Hybrid II 50th percentile male ATD (40 FR 33466; August 8, 1975).

instances, a close examination of the data, dummies, and procedure was performed to pinpoint the source of the variability. Corrective actions were taken in most cases.

Our investigative criteria for repeatability uses a slightly lower CV than for reproducibility (5% vs. 6%) as shown in Table 3. Since repeatability is an assessment of the same dummy by the same test laboratory, whereas reproducibility is an assessment of multiple dummies at more than one lab, reproducibility assessments include many more sources of variability. Hence, repeatability CVs are generally lower than reproducibility CVs.

Table 3. CV Score Categorization for Repeatability and Reproducibility²⁸

Repeatability CV Score	Reproducibility CV Score	Assessment
< 5%	< 6%	No further investigation; all trials within $\pm 10\%$ of the target response.
5% - 10%	6% - 10%	Sources of variability investigated. One or more trials beyond $\pm 10\%$ of target response.
$\geq 10\%$	$\geq 10\%$	Corrective actions considered for revisions to test procedure or dummy design. Several trials beyond $\pm 10\%$ of target response.

R&R in Sled Tests

Since the Q3s dummy is being considered as a measurement device for a proposed regulatory test that would evaluate CRS performance in side impact crashes,

²⁸ The assessment categories in Table 3 differ slightly from those applied during the NPRM stage. In the NPRM R/R analysis, a similar Table 3 categorized the CV ranges as either “Excellent,” “Good,” “Marginal,” or “Poor.” For this final rule, we do not use these terms in the table to describe the CV ranges. Rather, the new Table 3 provides further explanation of the action taken by the agency when the CV for a particular test condition was in a specified range, which, we believe, is more informative and helpful to the reader. Also, although the previous nomenclature for the CV ranges provided a convenient shorthand, we believe the terms it used could be misconstrued by the reader as reflective of a final assessment of the qualities of the ATD being tested.

NHTSA assessed the R&R of the dummy in actual CRS side impact sled tests. This assessment was discussed in the NPRM (78 FR at 69951-69953), where two Q3s units were tested five times each. Of the greatest importance to the assessment were the two measurements associated with injury assessment reference values for CRS requirements under the proposed side impact upgrade to FMVSS No. 213. These were the response of the head²⁹ and the lateral thorax displacement.

The CVs for the response of the head were less than 3% for all measures of R&R. For the lateral thorax displacement, the CV for reproducibility was also under 6%, and CV for repeatability was under 5% for one of the two Q3s units. For the other unit, the data in one of the tests was quite different from the others. This discrepancy was traced to an inconsistency in the pre-test position of the dummy's elbow in one of the tests which had resulted in a CV for repeatability of 9% for that unit.

In consideration of the elevated CVs, NHTSA ran another ("supplemental") series of sled tests with an improved arm-positioning protocol. This was also described in the NPRM (78 FR at 69952-69953). Five trials were run with a single unit. The repeatability for the thorax displacement in this series had a CV of 4%. The response of the head again was highly uniform, with a CV of 3%.

Given this high degree of uniformity in those tests and since the design of the dummy was essentially unchanged, NHTSA was satisfied with the R&R of the Q3s in sled testing and determined there was no need to perform additional sled testing for a final rule.

Comment Received

²⁹ The response of the head was measured by the acceleration of the head. Additionally, R&R of the head was also assessed via its injury correlate, the head impact criterion (HIC). HIC is computed from the head acceleration measurements.

In its comments, Dorel said that it computed a CV of 32.6% for HIC results from ten tests in the supplemental series.

NHTSA Response

The agency believes that Dorel may have misread the results of this series of tests. There were only five tests in this series, not ten as suggested by Dorel. None of the HIC values listed by Dorel correspond with those in NHTSA's test series, so it is unclear where Dorel's data were derived. The agency's test data are available to the public in NHTSA's Biomechanics Data Base (BIODB).³⁰ The CV in sled testing was only 3% for the HIC values. Given these data, Dorel's comment appears to be mistaken. In view of this high degree of uniformity, NHTSA is satisfied with the R&R of the Q3s in sled tests.

R&R in Component Qualification Tests

In the NPRM, acceptance criteria for the qualification tests were proposed to assure that the high level of R&R exhibited in the sled tests would be preserved in any dummy presented for compliance testing. In other words, the qualifications would serve to weed out any dummy that had a substantially different response from the uniformity of the original four units. The proposed acceptance criteria were based on a series of eleven component tests with multiple Q3s units in replicate trials. An upper limit and lower limit for an acceptable response were set for each test. The limits were chosen to be wide enough to account for normal variations in dummy and laboratory differences, and narrow enough to assure consistent and repeatable measurements in compliance testing.

As part of this analysis, R&R was assessed for each set of qualification test outcomes. As discussed in the NPRM, most CVs were well under 5% and all were under 10%. The agency

³⁰ The Biomechanics data base may be accessed at: <http://www.nhtsa.gov/research-data/databases-and-software>.

was aware, however, that for the NPRM the assessment was carried out using only four units, with all tests run at a single laboratory (VRTC). NHTSA explained in the NPRM that the agency anticipated finalizing the Q3s limits based on additional qualification data we would receive subsequent to the NPRM (78 FR at 69959). Various commenters responding to the NPRM expressed the view that the repeatability and reproducibility assessment of the Q3s ought to be assessed across various test facilities. Some asked for more data from tests with more dummies to round out the qualification corridors.

After the NPRM was published, NHTSA proceeded to obtain more qualification test data as it had planned. NHTSA investigated whether newer dummies tested at different labs exhibited the same level of R&R as NHTSA's original units. In the test program NHTSA designed in mid-2014, the agency used different labs to test both newer Q3s units and the original dummies, and obtained data that could be compared to the existing NPRM data from the original four units.

In 2014 and 2015, NHTSA systematically tested three new units that HIS delivered to end-users and three of the agency's original four dummies. NHTSA examined the R&R of the Q3s's performance to assess all sources of variability so as to identify the degree of variability and whether it was due to a non-uniform test procedure at a lab (and among the labs), an aspect of dummy design, or the dummy manufacturer's production of Q3s units. This systematic approach enabled NHTSA to assess the potential to which factors resulting in the variability could be remedied, adopt measures to mitigate the variances where possible, and assess the quality of the data on the Q3s. The testing also provided data that helped round out the qualification corridors. The program is discussed below. Test results and analyses are discussed

in detail in a NHTSA report entitled, “NHTSA’s Q3s Qualification Testing, 2014-2015, May 2016.”³¹

V. Post-NPRM Test Program Overview

a. Test Locations

NHTSA collected data from tests run at three different laboratories (Calspan, MGA and HIS) independent of NHTSA, and conducted additional tests at NHTSA’s VRTC.

At each independent lab, a full set of qualification tests were run (consisting of 11 different types of tests) on two NHTSA-owned units and a new unit. Several trials, or repeat tests, were carried out on each dummy for each of the 11 qualification tests. Tests were done using qualification test equipment owned by each laboratory. Tests were run in strict accord with the procedures described in the NPRM. The input parameters for each test had to conform to the specifications set forth in the proposed qualification procedures. For example, a test in which the probe impact speed did not meet the required parameters did not count toward the total test repetitions. After each test, a post-test inspection of the dummy was carried out to determine if the ATD incurred any damage resulting from the test.

NHTSA Tests at Outside Labs – Calspan and MGA

NHTSA contracted the services of Calspan and MGA to perform the series of qualification tests. The test series are summarized in Table 3. All tests were carried out between January through March 2015.

NHTSA In-House Tests (VRTC)

Prior to shipping NHTSA’s two dummies to Calspan and MGA, NHTSA tested the ATDs to the qualification tests at VRTC, but only one trial per test condition was carried out.

³¹ A copy of the report has been placed in the docket for this final rule.

These results (in addition to those provided in the NPRM) served as a comparative baseline for subsequent tests on the same units at the outside labs. Also, the agency arranged with Britax to test its new Q3s dummy that Britax had received from HIS in 2014. The tests were conducted at VRTC, and the results were added to the data pool.

Tests at HIS

In addition to the data NHTSA itself collected, the agency was also given data by HIS. In 2014, NHTSA lent HIS two of NHTSA's Q3s dummies for HIS to use to compare its qualification procedures and equipment to that described in the NPRM. HIS ran the qualification tests and provided NHTSA with the data from the tests. The agency also obtained from Calspan, MGA and Britax the qualification results performed by HIS on the new Q3s units sold to those end-users. These data were supplied by HIS to each respective purchaser of the dummy at the time of delivery. The owners, in turn, provided the data to NHTSA. The test results were added to the data pool.

Table 4, below, provides an overview of the qualification testing conducted at each lab.

Table 4. Overview of Q3s Qualification Testing

Lab	Q3s serial no.	Dummy owner	No. of Trials	Year of tests	Note
VRTC	004	NHTSA	5	2012	Results shown in NPRM
	006	NHTSA	5	2012	Results shown in NPRM
	007	NHTSA	5	2012	Results shown in NPRM
	007	NHTSA	1	2014	Prior to HIS testing
	007	NHTSA	1	2015	Prior to MGA testing
	008	NHTSA	5	2012	Results shown in NPRM
	008	NHTSA	1	2015	Prior to MGA testing
	3538	Britax	5	2015	Leased from Britax
HIS	004	NHTSA	3	2014	Leased from NHTSA
	007	NHTSA	3	2014	Leased from NHTSA
	3538	Britax	2	2014	Pre-delivery to Britax
	5860	MGA	2	2014	Pre-delivery to MGA
	059	Calspan	2	2014	Pre-delivery to Calspan
MGA	007	NHTSA	5	2015	Contract with NHTSA

	008	NHTSA	5	2015	Contract with NHTSA
	5860	MGA	5	2015	Contract with NHTSA
Calspan	007	NHTSA	5	2015	Contract with NHTSA
	008	NHTSA	5	2015	Contract with NHTSA
	059	Calspan	5	2015	Contract with NHTSA

b. Component Tests in the Post-NPRM Test Program

The component tests were the 11 qualification tests proposed for the Q3s. For each test, there were at least 2 dummy responses for a total of 35 in all. Of the 35 responses, 20 were derived from peak values (such as the peak resultant acceleration for the head drop test or maximum probe force for the pendulum tests). Those 20 were assessed for R&R.³² The 20 measurements that NHTSA assessed for R&R encompassed each of the eleven types of qualification tests.

c. Controlling Variability

An assessment of dummy R&R is dependent on controlling variability within and among test labs in conducting the qualification tests. A dummy must provide repeatable and reproducible results in the tests, but a qualification test must be repeatable and reproducible to serve its purpose to either qualify or disqualify a dummy.³³ Controlling variability within and among test labs is important for assuring the qualification tests fulfill their purpose.

With this in mind, when NHTSA collected post-NPRM data and observed variability in the test results, the agency closely analyzed any effect a test lab's internal practices, protocols and procedures might have had on the results. Variability caused by a lab's not being able to run

³² The other 15 were time-related criteria (such as the time peak at which the maximum neck rotation occurs) or criteria that contained zero in their intervals (such as the peak off-axis acceleration in the head drop test). NHTSA did not include these measurements in the R&R assessment because the CV statistical measure is not a good indicator of variability in these instances.

³³ If a dummy is qualified, it can act as an objective device in compliance tests such as those proposed in the FMVSS No. 213 NPRM. If disqualified, a dummy must be replaced or repaired.

a test repeatedly (“test repeatability”) is discussed in each section below. In addition, NHTSA assessed the objectivity of the test methods themselves, or “test reproducibility,” to assure that tests with the Q3s at different labs would produce reproducible results.

NHTSA also identified instances in which repeatability was compromised due to a discernable problem with the dummy, such as variability in a particular dummy’s responses over time (“dummy repeatability”).

The agency also assessed “dummy reproducibility,” i.e., the uniformity of the dummies themselves. This is partly a function of how well HIS was able to manufacture dummies that behave uniformly. Thus, NHTSA was especially interested in comparing the responses of older versus newer units. The agency only used the results from the same lab for this assessment.

Summary of Test Repeatability Assessment

NHTSA assessed the ability of each of the three outside labs (Calspan, MGA and HIS) to attain a repeatable response by analyzing the effect test lab practices, protocols and procedures might have had on the results. Test repeatability was based on same-lab trials with the same dummy: serial no. 007 (owned by NHTSA), the only dummy tested by all three labs. Thirty-five responses were assessed at each lab.

Additionally, NHTSA performed a separate assessment at Calspan and MGA based on tests with NHTSA-owned dummy serial no. 008. (HIS did not test serial no. 008.)

At Calspan, all test repeatability CVs were below 5% for all tests and for both dummies (serial nos. 007 and 008). At MGA, the CVs were below 5% except in two instances: the Mz measurement in the “Neck Torsion” test (5.9%) and in the resultant head acceleration in the “Lateral Head Drop” test (10.0%). Both occurred with dummy serial no. 007. All tests at MGA on serial no. 008 yielded CVs below 5% for test repeatability. At HIS (with serial no. 007 only),

the CVs were below 5% in all but two instances: the “Lateral Head Drop” test (5.6%) and the “Thorax With Arm” test (9.3%).³⁴

These findings demonstrate a high level of test repeatability and the ability of the three outside labs to carry out the qualification tests. In summary, NHTSA is confident in the data generated by the test labs in this test program.

Summary of Test Reproducibility Assessment

NHTSA assessed the objectivity of the *test methods* to provide consistent results at different labs. The agency evaluated test results from replicate tests on the same dummy (Q3s serial no. 007) at different labs (this ATD was the only unit tested at all four labs). NHTSA also assessed test reproducibility with Q3s serial no. 008, which was tested at VRTC, MGA, and Calspan (but not HIS).

For all 35 sets of measurements, all but three had test reproducibility CVs under 6%. The three sets of tests that had CVs over 6% were: the resultant head acceleration in the lateral head drop test; the Mx component in the lateral neck test; and the pubic force in the pelvis test.³⁵ The results are discussed in greater depth in a later section below.

Summary of Dummy Repeatability

Dummy repeatability is a measure of how much the response of a given dummy changes during the course of testing. One with a high degree of repeatability exhibits little change from one qualification trial to the next. A change in response could be caused by a hardening or softening of polymeric components over time or the propagation of cracks and other defects that

³⁴ The few instances where CVs for test repeatability were greater than 5% are discussed in greater detail below in this preamble.

³⁵ As will be discussed later in this document, NHTSA has corrected aspects of the lateral head drop and lateral neck test procedures that had contributed to the elevated variability in the results. Further, the agency has decided not to adopt the pubic force limit in the pelvis test.

occur over repeated impacts. Repeatability could also be affected by loose assembly tolerances. Dummies are routinely disassembled and re-assembled, and wide allowances for settings (such as the joint torques) could result in poor repeatability.

During the course of the qualification testing of the Q3s, NHTSA closely examined the root cause of any variability in trial-by-trial test results that might reveal a problem with the dummy (i.e., a problem with dummy repeatability) rather than simple test variability. There was only one instance where repeatability was compromised due to a discernable problem with the dummy.³⁶ This instance, which affected the uniformity of the lumbar spine, is discussed below, along with NHTSA's simple fix to the problem. Aside from that, there were no other problems with dummy repeatability in any of the tests. Once the fix to the lumbar was implemented, it was demonstrated to have a highly uniform response. NHTSA also examined changes in the response of the dummy over time and found that such changes had only a negligible effect on dummy repeatability. This is also discussed below.

Loosening of lumbar cable. NHTSA observed that in the lumbar flexion tests, the first trial tended to register a lower moment than subsequent trials. This was consistent with all dummies at all labs. NHTSA examined the wire cable that runs through the center of the rubber column, which was initially placed under tension by tightening a lock nut with a nylon insert³⁷ prior to the first trial. After the first trial, it was apparent that the nut did not stay in its set position. It could be loosened by hand.

³⁶ *Torn lumbar column.* Throughout NHTSA's test experience with the Q3s, dating back to the NPRM, there was only one instance where dummy durability was an issue. In the very last series of tests on serial no. 008 run at Calspan in March 2015, a tear in the rubber column within the lumbar assembly was observed after the first lumbar qualification trial. In subsequent tests, the tear became visibly worse and the lumbar moment and rotation both increased with each successive impact. The biggest jump occurred between trials 1 and 2, where the maximum neck rotation jumped from being centered within the limits of acceptability to just outside the limits. The agency views this instance as a successful demonstration of the ability of the qualification test to weed out a damaged unit.

³⁷ A nut with a nylon collar insert, often referred to by its tradename, NYLOC, is a nut that resists turning.

This affected the response of the lumbar spine, as the tension on the cable governs the response of the lumbar column. NHTSA controls this in the PADI by prescribing the torque for the nut on the center cable. However, the torque on a nut with a nylon insert is partly dependent on the condition of the nut itself. A newer nut can resist more torque without affecting the cable tension than a worn nut. In other words, the tension on the cable (and the moment) can vary depending on the condition of the nylon insert of the nut. To alleviate this situation, NHTSA has replaced the nut with two jam nuts, i.e., two standard nuts twisted against each other.

No pronounced changes in response over time. NHTSA assessed also the agency's older unit, serial no. 007, for signs that one or more responses was exhibiting a definitive change during the course of testing due to any sort of deterioration. This unit was tested repeatedly over the course of many years, with the initial tests pre-dating the NPRM. NHTSA examined data from 2012 to 2015 to see if there were any definitive trends in response changes.

To avoid any lab-to-lab variability that could act as a confounder, NHTSA assessed the results from a single lab, VRTC. Data were collected in three separate periods: in 2012 (five trials for the NPRM), in 2014 (one trial prior to sending it to HIS), and in 2015 (one trial just prior to the MGA/Calspan series). Of all the responses, only two had a definitive change in response over the three test periods: lumbar moment and shoulder deflection. In these instances, the 2015 trial produced a lower/higher response than any of the previous trials (lower for the lumbar moment, higher for the shoulder deflection), while the 2014 trial produced a result that was between the 2015 and 2012 trials.

Yet, even for these two instances, the change in response was negligible. For the lumbar moment, the change in moment was just 2 Nm: 82.6 Nm (lowest of the 2012 trials), 82.1 Nm (in 2014), and 80.6 Nm (in 2015). Similarly, the change in shoulder deflection was less than 1 mm:

19.0 mm (highest of the 2012 trials), 19.5 mm (in 2014), and 19.6 mm (in 2015). In both instances, all responses fell well within the qualification limits specified in this final rule.

NHTSA observed no other problems with deterioration over time.

In summary, NHTSA has determined that there are no problems with dummy repeatability that might compromise the overall uniformity of Q3s responses. The one problem with dummy repeatability has been resolved and there are no further concerns.

Summary of Dummy Reproducibility Assessment

In assessing dummy reproducibility, NHTSA examined the uniformity of the dummies themselves. This is partially a function of how well the manufacturer HIS produced dummies that behave uniformly. The agency was especially interested in comparing the responses of older vs. newer units.

To eliminate the effects of lab-to-lab variability, NHTSA only used same-lab results for this assessment. NHTSA also combined results for left and right aspects since the dummy was designed to yield the same response in impacts to both. Thus, four separate assessments of dummy reproducibility were carried out, one per lab, against the units referenced in Table 5 below.

Table 5. Q3s Dummies Used in Reproducibility Assessments at Various Labs

Lab	Serial nos. of older NHTSA units	Serial nos. of new units
VRTC	004, 006, 007, 008	3538 (Britax-owned unit)
HIS	004, 007	3538 (Britax-owned unit); 5860 (MGA-owned unit); 059 (Calspan-owned unit)
MGA	007, 008	5860 (MGA-owned unit)
Calspan	007, 008	059 (Calspan-owned unit)

As a secondary assessment, NHTSA compared only the three new units against each other in tests at HIS (HIS was the only lab that tested all three new units). This gave the agency a better sense as to whether the newer units, when considered as a single lot, had more inter-dummy variability as compared to NHTSA's original lot of four units. (As a point of reference, NHTSA assessed dummy reproducibility in the NPRM based on tests with the agency's four units (serial nos. 004, 006, 007, and 008) at VRTC and the CVs were less than 6% in all eleven qualification tests.)

The agency's ratings of dummy reproducibility of the new units in the secondary assessment produced CVs in the 6% to 10% range for about 25 percent of the qualifications. The CVs of the other 75 percent were all under 6%, and no further investigation was performed.

NHTSA investigated any set of tests with a CV above 5% for repeatability and 6% for reproducibility to determine the source of the variability. Responses in the lateral head drop and thorax impact test were non-uniform. When units manufactured since 2014 were compared to older units as two separate sets, NHTSA observed differences in responses for several qualifications. In general, the newer Q3s units did not exhibit the same high level of dummy reproducibility observed in NHTSA's four older units.

As explained later in sections below, in a few limited instances, values obtained from a qualification test of a newer ATD were too dissimilar to those from tests of other Q3s units to be included within a set of reasonable qualification limits. Including them would have unacceptably widened the limits, lessened the uniformity of the ATDs, and unacceptably reduced the biofidelity of the Q3s. In such instances, the agency considered the particular dummy part

substandard and the values from tests of the part beyond the performance criteria for the qualification test.³⁸

VI. Results of the Post-NPRM Test Program and the Final Acceptance Criteria for the Qualification Tests

a. Background

In the NPRM, NHTSA proposed acceptance criteria based on replicate trials conducted sequentially on four NHTSA-owned Q3s units at a single laboratory (VRTC). These tests were used to set the upper and lower limits of the qualification intervals and were used to assess the repeatability of the Q3s.

Of the 35 measurements, the bounds of 21 measurements were proposed as ± 3 standard deviations from the mean. Of the 14 other measurements that were set to $\pm 10\%$, 12 were set at ± 2 standard deviations from the mean or greater. Two had bounds that were less than ± 2 standard deviations: peak pubic load (1.9 standard deviations) and peak neck torsion moment (0.5 standard deviations).

At the time of the NPRM, NHTSA recognized that 3 standard deviations comprised a wider-than-usual bound from a probabilistic standpoint. NHTSA regarded the bound as a starting point based wholly on the statistics of the measurements. Three standard deviations were wide enough to account for normal variations in dummy and laboratory differences and narrow enough to assure consistent and repeatable measurements in compliance testing. Moreover, many of the bounds were, in practice, extremely narrow from an operational

³⁸ The high CVs for dummy reproducibility indicates that some newer Q3s dummies in the field may have to have parts reworked or replaced to produce a “pass” in the head drop test and thorax without arm test. Going forward, this final rule’s setting of the acceptance criteria for the qualification tests should help provide checks and controls in the ATD’s manufacturing processes, which in turn should facilitate the production of ATDs that meet the acceptance criteria for the qualification tests.

standpoint owing to factors (equipment, set-ups, technicians) lending themselves to highly repeatable testing at a single lab (VRTC).³⁹ NHTSA anticipated finalizing the Q3s limits based on additional qualification data the agency would receive subsequent to the NPRM (78 FR at 69959).

b. Process for Setting the Final Qualification Limits

The data from the post-NPRM test program and other sources, discussed above, have helped NHTSA finalize the qualification test procedures and round out the qualification corridors. In specifying qualification tests and acceptance criteria for the qualification tests, NHTSA's goal is to assure that a "pass" is a true indicator of a dummy that is uniform in its design and performance. This goal is achieved by ensuring that the tests themselves are repeatable and reproducible, and by setting limits (or tolerances) on the qualification targets.

As discussed in the previous section, test and dummy R&R have been demonstrated at four different labs. The proposed targets and acceptance criteria for the qualification tests in the NPRM were based entirely on the statistics of the agency's replicate tests. NHTSA considered those targets and limits as starting points, given that the agency did not have data from other labs. Since then, the agency has expanded the qualification database by adding much more data on tests with several dummies across four test labs. For this final rule, the qualification targets and limits are based on the statistics of the measurements, but also on the following factors.

Other Part 572 ATDs. NHTSA considered the qualification limits of the other Part 572 ATDs in use today in setting those for the Q3s. For example, the qualification bounds for the most recent dummy incorporated into Part 572 (the Hybrid III 10-year-old child dummy (HIII-10C); *see* Part 572 Subpart T), are derived from tests on about 30 different dummies, with data

³⁹ For example, the NPRM's 3-standard-deviation interval for the time at which the peak neck moment occurs was only 7 ms.

supplied from about ten different laboratories. For the HIII-10C, there are nine qualifications based on a maximum measurement (such as a peak force), and the average limits (i.e., the values defining the range of acceptable measurements) are 9.9% from the midpoint. The low is 8.4% (neck rotation in the neck extension test) and the high is 10.8% (seen in two qualifications: neck moment in the extension test and chest deflection in the thorax impact test).

A limit of 11% from the midpoint is the average for all Part 572 dummies and all qualifications. NHTSA has used this value as a benchmark for setting the limits for the Q3s in this final rule. The agency scrutinized any limit above 11% from the midpoint to ensure it could be justified.

Biofidelity targets. In setting the qualification limits, the agency considered the biofidelity targets that were used as the basic design criteria of the Q3s during its development. The corridors surrounding biofidelity targets are generally wider than qualification limits owing to larger variances associated with tests with human subjects. In the NPRM, NHTSA compared the responses of various Q3s body regions against their respective human biofidelity corridors. For the most part, the responses of the body regions fell within the biofidelity corridors (including the responses for the head and thorax). For the final rule, NHTSA made sure that a contemplated qualification limit would not result in acceptance of a dummy response that is outside the biofidelity corridors.

Some body regions, such as the shoulder, were shown in the NPRM to be stiff relative to the biofidelity targets. For these body regions, any shifts in the qualification limits for the final rule were generally made in a direction that was closer to the biofidelity target. In other words, NHTSA avoided moving the nominal qualification target further from the biofidelity target.

Test input parameters. For this final rule, NHTSA has not changed the input parameters in any of the eleven qualification tests from those of the NPRM. The input parameters include impact speeds, probe masses, drop heights, and dimensional measurements related to dummy positioning. Tolerances on test inputs are also unchanged.

For this final rule, nineteen Q3s qualifications are centered around a maxima. For these measurements, the limits proposed in the NPRM were spread around a nominal target response by plus or minus 9.9% (on average) of the target. The average spread in this final rule is slightly higher, at 10.1%. However, as seen in Table 1, *supra*, the limits are narrower for 11 of the nineteen qualifications, and only the shoulder has limits greater than 12%: internal shoulder deflection (12.8%) and shoulder probe force (12.3%).

Newer dummies and other test labs. NHTSA considered the population of all dummies tested – both old and new – and all four labs that were used. Recognizing that the newest dummies may be representative of the future population of Q3s dummies, steps were taken to be inclusive of them as reasonably possible. NHTSA also recognized that all four labs were highly experienced in dummy qualification testing, so in theory any dummy that qualified at one lab should have qualified at the others. When this was not the case, the situation was analyzed to determine the source of the problem.

Balancing the factors. In setting the final qualification limits for the final rule, NHTSA examined the test data on a trial-by-trial basis and balanced all the factors discussed above. For example, for the lumbar flexion qualification, while keeping the 11% goal in mind NHTSA set the qualification limits such that serial no. 059 (a new unit owned and tested by Calspan) was just under the upper limit in four of five trials, while serial no. 5860 (a new unit owned by and tested by MGA) was just over the lower limit in four of five trials. Balancing the factors enabled

NHTSA to set qualification limits spread 10.9% from the nominal target in a manner that included as many test trials from the new units as reasonable. In contrast, if the 10.9% limits were centered around the average of all responses, the Calspan unit would have failed to qualify in all trials.

In summary, the agency analyzed the data from the testing of the seven Q3s units (the four NHTSA-owned units and the three new units) to the qualification tests proposed in the NPRM, assessing, among other matters, the measurements made by the units when tested to the qualification tests and the R&R of the dummies. Tests were run for both right and left side impacts. Average, standard deviation, and coefficient of variation were computed for each required measurement parameter of each qualification procedure.

c. Head

The head injury criterion (HIC), based on the Q3s's head acceleration, has been proposed as a criterion in the FMVSS No. 213 side impact NPRM and is important for assessing countermeasures that protect the child's head in side impacts. Thus, a uniform response of the dummy's head-neck system is important to achieve. Two qualification tests serve to assure the uniformity of the head response in an impact: a lateral head drop test and a frontal head drop test. In both qualification tests, the pass/fail specification is based on the resultant acceleration measured at the center of gravity (CG) of the head. Procedures for both tests also place limitations on the off-axis acceleration to assure that the free-fall of the head is uniform prior to impact.

Lateral Head Drop

The lateral head drop test is carried out by cradling the head within a looped wire rope, suspending the head 200 mm above a steel plate, and releasing the wire rope. The head is

oriented within the cradle so that its lateral aspect strikes the plate. Lateral impacts are carried out on the left and right aspects of the head.⁴⁰

The NPRM proposed that the head must respond with peak resultant acceleration between 113 g and 140 g when dropped from a 200-mm height such that the side of the head lands onto a flat rigid surface (lateral head drop). Off-axis acceleration was proposed to be +/- 20 Gs. These values were based on tests of NHTSA's four Q3s dummies.

For the final rule, NHTSA has set the lateral qualification limits as: peak resultant acceleration is 114-140 Gs (spaced 10.2% from the range's midpoint of 127 Gs). Off-axis acceleration: +/- 15 Gs. These values are based on tests of the seven Q3s dummies.

Test Repeatability. Test repeatability problems became apparent once the agency began to assess lateral head drop data from the outside labs. NHTSA believes that the problem existed even at the time of the NPRM as many of the CVs reported in the NPRM were just under 5%, which, upon reexamination, were high for such a simple test. None of the CVs for the frontal head drop was over 2 percent.

The problem was first discovered in the initial tests performed at MGA on serial no. 007. Fourteen trials were needed to attain the desired sample of ten trials (five left, five right) in which the off-axis acceleration was under the NPRM's requisite 20 Gs (and only three of those were under 15 Gs). The CV for the resultant head acceleration was over 8% in the trial tests, which is unacceptably high.

The variability was eventually traced to MGA's head drop apparatus. MGA had used a one-piece cable loop to cradle the head, and the cradle was released via a magnetic actuator.

⁴⁰ Cradling of the head is shown in the regulatory text figures, but specifics on how to release the head are left to the operator.

Upon release, the head rotated slightly during its free-fall creating elevated off-axis accelerations and high variability in the resultant accelerations.

For its subsequent series of tests on serial nos. 008 and 5680, MGA developed an improved test protocol that included a two-cable cradle that mitigated the problem. Off-axis acceleration was below 20 Gs in all twenty trials and below 15 Gs in sixteen of the trials.⁴¹

Calspan had similar difficulty with its drop apparatus, which made use of a pneumatic actuator to release the cradle. In its initial tests, Calspan needed nineteen trials to attain the desired sample of 5 left and 5 right trials with an off-axis acceleration under 20 Gs. However, like MGA, Calspan could achieve the 20 G limit in their subsequent series (with ten trials each with serial nos. 008 and 059).

At VRTC, the cradle was released by cutting the end of the cable. There were no problems with keeping the off-axis accelerations below 20 Gs, though in retrospect it was still unusually high for such a simple test (the average was 12 Gs, with a range of 7-18 Gs).

High off-axis acceleration was particularly problematic for serial no. 007 (one of the older, NHTSA-owned units) at all four labs where it was tested (53 trials total). NHTSA observed that the flesh parting line⁴² on the head coincided with the point of impact, causing added variability for that particular unit (the effect was more pronounced with serial no. 007 than with other dummies.) About half of the tests with no. 007 produced off-axis accelerations greater than 15 Gs, with 13 tests (21%) greater than 20 Gs. Just 14 tests were less than 10 Gs.

⁴¹ The cradle problem at MGA highlighted the need for a drop test mechanism with a high degree of precision. Any slight deviation in the point of impact was shown to produce a large variation in both the resultant and off-axis acceleration. This was particularly true in the lateral head drop, where the curvature of the head at the point of impact contributes to the variation.

⁴² When two halves of a mold meet, the corresponding line or seam appearing on the molded object is referred to as the parting line.

When data from VRTC, Calspan, and HIS were further examined, it became apparent that elevated off-axis acceleration was correlated with high variability in the resultant acceleration. The scatter in data is evident in Table 6 (which represents all dummy tests, not just serial nos. 007 and 008). The CV in the resultant acceleration is shown to increase when the off-axis acceleration falls in higher ranges. It is highest (10.24%) when the off-axis acceleration is above 15 Gs and it is lowest (4.04%) when under 10 Gs. In the ranges of 0-10 Gs, 0-15 Gs, and 10-15 Gs, the CVs are all about the same and all under the 5%. Thus, NHTSA concludes that 15 Gs is a more appropriate limit than 20 Gs.⁴³

Table 6. Relationship Between Off-Axis Acceleration and Variability in Resultant Acceleration

Off-Axis Acceleration, Gs	No. of Trials	Resultant Acceleration	
		Limits, % of midpoint	CV (%)
0-5	0	-	-
0-10	21	7.7	4.04
0-15	84	10.2	4.47
10-15	64	10.2	4.58
0-20	114	16.2	6.38
10-20	94	16.2	6.71
15-20	30	16.2	9.20
Over 15	34	18.4	10.24
All	118	18.4	7.34

For this final rule, NHTSA has set the limit for off-axis acceleration to +/-15 Gs.

NHTSA notes that this limit is the same as those for the two other Part 572 side impact dummies (Subpart U – ES-2re (50th percentile adult male) and Subpart V – SID-IIsD (small adult female)).

NHTSA believes the 15 G limit (as opposed to an even lower limit) is sufficient to assure

⁴³ All NPRM upper/lower limits, including 20 Gs, were derived from the statistics of the tests. With the further data obtained in the post-NPRM program, NHTSA has determined that 20 Gs was too broad.

dummy uniformity, and that lowering it to a lesser value is needlessly onerous on test labs because it will likely require many more trials to achieve acceptable test results. Unlike a frontal drop, where the direction of the drop is symmetric with the sagittal plane of the head, the lateral drop is asymmetric, making it difficult to attain an off-axis acceleration below 10 Gs.

When only those tests where the off-axis acceleration was under 15 Gs were included, the CVs for repeatability and test reproducibility for the peak resultant acceleration were all 5% or less at all labs with all Q3s dummies.

The agency notes that attaining the requisite +/- 15 G may require multiple drop tests. Nonetheless, in NHTSA's test program all labs could eventually attain this limit with each dummy they tested. Moreover, NHTSA believes it would be a relatively simple matter for labs to come up with a way to run the test such that the head does not slip and turn during its free fall, which should enable them to meet the 15 G off-axis limit without difficulty.

Dummy Reproducibility. When assessing dummy reproducibility in the lateral drop test, for the reasons stated above the agency also omitted drop tests where the off-axis head acceleration is greater than 15 Gs, and the tests at MGA on serial no. 007. There was still an ample number of trials (84) without those tests to make a reasonable assessment of dummy reproducibility.

The CVs for dummy reproducibility in lateral head drop tests at the various labs ranged for 7.0% to 11.7%, which reflects a fairly wide range of head acceleration responses. Nonetheless, the qualification criteria are set at 114-140 Gs, which reflects the upper and lower limits spaced only 10.2% from the midpoint.

NHTSA concludes that the qualification limit of 10.2% is appropriately balanced to accommodate dummy reproducibility without being unreasonably hard for test labs to attain.

The narrowness of the final limits is also consistent with other Part 572 dummies, as shown in Table 7 below, and is needed to assure a sufficient level of uniformity in head response. As stated above, the head's acceleration is an important criterion for assessment of head injury. Thus, the acceptance criteria should be narrow enough to achieve a uniform response of the head-neck system of the Q3s.

Table 7. Acceptance criteria for resultant head accelerations in head drop tests for various ATDs

Dummy	Aspect	Resultant Head Acceleration		
		Lower limit, G	Upper limit, G	+/- % of midpoint
Q3s (final rule)	Lateral	114	140	10.2%
Q3s (proposed)	Lateral	113	140	10.7%
Side Impact Dummy Crash Test Dummy, Small Adult Female (SID-IIIsD)	Lateral	115	137	8.7%
Side Impact Crash Test Dummy 50th Percentile Adult Male (ES-2re)	Lateral	125	155	10.7%
Q3s (final rule)	Anterior	255	300	8.1%
Q3s (proposed)	Anterior	250	297	8.6%
Hybrid III (HIII) 3-Year-Old Child Crash Test Dummy (HIII-3C)	Anterior	250	280	5.7%
Six-year-old Child Test Dummy (HIII-6C)	Anterior	245	300	10.1%
HIII 10-Year-Old Child Test Dummy (HIII-10C)	Anterior	250	300	9.1%
HIII 5th Percentile Adult	Anterior	250	300	9.1%

Female (frontal) Test Dummy				
--------------------------------	--	--	--	--

NHTSA observed that the envelope of 114-140 Gs reflects the data from all the considered tests of the Q3s, but that two of the three newest dummies, those owned by Calspan and Britax, registered high head acceleration responses relative to NHTSA's older units and the newer MGA unit. NHTSA had to decide how to set the qualification limits for the head given the differences in dummy head performance.

If NHTSA had set qualification limits to include at least one test trial from all dummies tested (the NHTSA-owned units and the three newer units), limits greater than 13% would have resulted. The agency was concerned that such limits would be too wide for regulatory purposes, especially because the Q3s's head acceleration measurements would probably determine a pass or fail in any future application of the dummy. No other Part 572 ATD has limits wider than 11% for a head drop test (anterior or lateral).

The agency also considered the possibility of calibrating the limits around the new units (which generally produced higher head accelerations) even though one or more of the NHTSA-owned units may not be able to qualify. When only the three new units were considered (combining data from tests at VRTC, MGA, HIS, and Calspan), limits within 11% were possible.

After further investigation, however, NHTSA decided against this alternative too. The agency's first step in assessing whether to use only the new units was to assess the biofidelity of the new Q3s units. When the agency assessed the head of the Britax unit (which produced the highest response) against the biofidelity targets to confirm that it was within the limits of acceptability, the agency found it was not. The limits of biofidelity acceptance are generally wider than qualification limits owing to the variability associated with human subjects. As

explained in the NPRM, the test to assess lateral biofidelity is slightly different from the qualification test (78 FR at 69949). Derived by SAE (Irwin, et al, 2002), the target response is referenced from the non-fracture zone of the head (opposite the point of impact). For a 3-year-old, the target resultant acceleration is 114-171 Gs.

The test results for the NHTSA-owned units fell squarely within these limits. For the Britax unit, however, the tests produced a resultant acceleration of 189 Gs, which is well beyond the limits of acceptability. Thus, if the qualification limits were recalibrated around the newer units, the limits would be set based on readings of a non-biofidelic dummy. NHTSA decided that such an approach would sacrifice dummy biofidelity and is unacceptable.

Accordingly, NHTSA decided that the final acceptance criteria for the lateral head drop qualification test should be centered around essentially the same midpoint as the NPRM. Thus, all NHTSA-owned units remain centered within the limits of acceptability. There is no potential sacrifice in biofidelity, unlike the result if limits were established around non-biofidelic Q3s units.

NHTSA notes that, under the qualification limits of this final rule, a “pass” was observed with the older NHTSA-owned units at all labs and in almost every trial. Newly-manufactured Q3s dummies, on the other hand, did not always qualify. Of the three new units tested, only the MGA unit consistently produced a passing result against the final qualification criteria. The Britax unit was well above the upper limit, a result that was observed repeatedly in all trials at both labs in which it was tested. The Calspan unit was borderline acceptable. HIS had reported responses within the limits, but Calspan was not able to consistently produce a passing result at its lab. Given these results, there is a possibility that some dummy heads of newer Q3s units in the field may need to be re-worked to pass the lateral head drop criterion of this final rule.

Frontal Head Drop

The NPRM proposed that the head must respond with peak resultant acceleration between 250-297 Gs (8.6% of the midpoint) when dropped from a 376 mm height. The head is oriented such that its sagittal plane is parallel with the direction of impact and the anterior-most aspect of the forehead strikes a steel plate. Off-axis acceleration was proposed to be +/- 15 Gs. These values were set based on tests of NHTSA's 4 Q3s dummies.

For the final rule, NHTSA has set the frontal qualification limits as: peak resultant acceleration is 255-300 Gs (8.1% of the midpoint). Off-axis acceleration: +/- 15 Gs (no change from NPRM). These values are based on tests of the seven Q3s dummies.

Test R&R. The CVs for test R&R were universally low at all labs and for all dummies (all below 4%). Unlike a lateral drop, the motion in the head in the frontal drop is symmetric about the sagittal plane, i.e., rotation of the head during and after the impact takes place about the y-axis only. This makes it much easier to produce a repeatable response and to attain a low off-axis acceleration. In the NPRM, the off-axis limit for acceleration was only 15 Gs (vs. 20 Gs for the lateral drop). The 15 G off-axis limit was easily met at all labs with all dummies. NHTSA notes that the 15 G limit for frontal drops is also consistent with other Part 572 dummies, as shown previously.

Dummy Reproducibility. For the frontal drop test, the CVs for dummy reproducibility were under 6% for all but one dummy – serial no. 5860, the MGA-owned unit. Relative to the others, the MGA head registered low responses at both labs (HIS and MGA) where it was assessed, resulting in an elevated CV statistic of 8.0% at HIS and 5.4% at MGA. If only the new units are considered (combining data from tests at VRTC, MGA, HIS, and Calspan), the CV statistic is 6.8 % for all three units vs. 3.4% when the MGA unit is excluded. The Britax and

Calspan units had high responses in the lateral drop tests but were in line with each other and with NHTSA's older units in the frontal head drop test.

The lower limit of 255 Gs coincides with the lower limit of an acceptable biofidelic response as described in the NPRM.⁴⁴ At this limit, the MGA unit did not qualify in any of its seven trials at either of the two labs where it was tested (HIS and MGA), as its response was too low. The highest response it produced in any of the trials was 242 G, well below the biofidelity target. This response is unacceptably low (non-biofidelic). Aside from the MGA unit, only the Calspan unit was at all marginal. Its response was borderline low in tests at HIS (253 Gs on average), but at Calspan it was squarely within the limits.

NHTSA's final upper limit of 300 Gs (raised from 290 Gs in the NPRM) is still well within the acceptable biofidelity limit of 315 G. There were no problems staying under the upper limit for any dummy in any trial at any lab. By raising the upper limit to 300 Gs, NHTSA is maintaining essentially the same limit widths (8.1% of the midpoint) as those proposed in the NPRM.

As noted above, a uniform head response for the Q3s is particularly important to assess child side impact protection. Thus, NHTSA has set the resultant acceleration limits for the frontal head drop narrower than the 11% guideline target for all responses. This approach is consistent with other Part 572 dummies. The Q3s width of 8.1% (i.e., the +/- limits of the nominal qualification target) is roughly the equivalent to the average of the other dummies.

d. Neck

A biofidelic and repeatable kinematic response of the head-neck system is important to quantify the protection offered by CRSs in an impact. The acceptable criteria for the neck

⁴⁴ "Biofidelity Assessment of the Q3s Three Year-Old Child Side Impact Dummy," *supra*.

qualification test in this final rule consist of three test components: lateral flexion, frontal flexion, and torsion neck pendulum tests. These tests serve to assure uniformity of the head kinematics in both a head impact and non-impact. In each test, the neck moment, the rotation of the neck, and the timing associated with the moment and rotation are assessed. All three use the conventional Part 572 swinging pendulum to apply a prescribed impulse to the neck, with a headform designed to mimic the inertial properties of the head attached to it.

Lateral Flexion

The lateral flexion test specifies a 3.8 m/s impact speed with a prescribed deceleration pulse. A column of collapsible aluminum honeycomb is used to decelerate the pendulum at a relatively constant level of force. Part 572 specifications for almost all other dummies use the pendulum/honeycomb device for testing necks. Test labs generally adjust the honeycomb in some manner (for instance, by modifying the number of cells engaged by the impacting face of the pendulum) to attain the prescribed pulse.

The NPRM proposed a maximum rotation of 77-88 degrees (6.7% from the midpoint). The maximum moment was proposed to be 25-32 Nm (12.3% of the midpoint).

This final rule sets the maximum rotation at 76.5-87.5 degrees (6.7% of the midpoint). The maximum moment is set at 25.3-32.0 Nm (11.7% of the midpoint).

Test R&R and Dummy Reproducibility. All four labs exhibited CVs below 5% for test repeatability in lateral flexion for both the rotation and the moment.

NHTSA did, however, observe some lab-to-lab variability in the bending moment which resulted in CVs for test reproducibility that ranged from 6.3% to 7.2% for both Q3s units that

were used in the assessment. This was not entirely unexpected.⁴⁵ The variability in test reproducibility is likely attributed to lab-to-lab differences in the aluminum honeycomb, such as the lab modifications of the number of honeycomb cells used in the qualification tests. Also, after impact, the trajectory of the headform does not occur within a single plane of motion because the neck bends along its non-symmetric axis. This generally reduces test reproducibility.

The agency did not discern any trends that would indicate that the responses of the necks have changed over time. Also, the CVs were under 5% for test reproducibility and under 6% for dummy reproducibility for all measures of neck rotation and neck moment. This further suggests that the variability is due to the variability in test equipment (i.e., honeycomb) among the various labs.

In summary, all dummies and all labs could demonstrate a qualification pass for both rotation and moment. The results show that the necks themselves were highly uniform, but test labs may need to evaluate different honeycomb configurations to demonstrate a passing response. Experimenting with honeycomb is typical of the qualification process with all Part 572 dummies.

Frontal Flexion

The NPRM proposed a maximum rotation of 70-82 degrees (7.9% of the midpoint), and a maximum moment of 41-51 Nm (10.9% of the midpoint).

For the final rule, the acceptance criteria for the frontal flexion test are set as: maximum rotation is 69.5-81.0 degrees (7.6% of the midpoint). The maximum moment is 41.5-50.7 Nm

⁴⁵ In the NPRM, the set of limits for the moment was constructed via the +/- 10% rule rather than +/- 3 standard deviations.

(10.0% of the midpoint). The frontal flexion test specifies a 4.7 m/s impact speed and its own deceleration pulse. Crushing of aluminum honeycomb is also used to generate the prescribed deceleration pulse.

Test R&R and Dummy Reproducibility. The CVs for test R&R and dummy reproducibility were universally low at all labs and for all dummies and for both neck rotation and neck moment (all below 4%). Unlike the lateral and torsion tests, the motion in the headform in the frontal flexion test is symmetric about the sagittal plane. In other words, rotation of the headform during and after the impact takes place about the y-axis only. This makes it much easier to produce a repeatable response and to attain a low off-axis acceleration.

For the neck flexion test, the wide intervals specified in the NPRM (built around 3 standard deviations) proved to be unnecessarily large, even with the latest results from the additional dummies tested at different labs added to the data pool. Therefore, NHTSA has narrowed the limits for the final rule from those of the NPRM. All dummies at all labs were demonstrated to pass at the narrower limits of the final rule.

Torsion

During CRS testing, the Q3s neck might flex with varying degrees of neck twist. The agency, therefore, proposed a procedure to assure that the neck is uniform under twist. The proposed neck torsion test uses a special test fixture attached to the Part 572 pendulum, which imparts a pure torsion moment to the isolated neck. It specifies a 3.6 m/s impact speed with a defined deceleration pulse. Qualification is based on the rotation and moment about the long axis of the neck.

The NPRM proposed that, for the neck torsion test, the maximum rotation must be 75-93 degrees (10.7% of the midpoint). The maximum moment is 8.0-10.0 Nm (11.1% of the midpoint).

For this final rule, the final acceptance criteria for the qualification test are set as follows. The maximum rotation limits are 74.5-91.0 degrees (10.0% of the midpoint). The maximum moment limits are 8.0-10.0 Nm (11.1% of the midpoint) (unchanged from the NPRM).

Test R&R and Dummy Reproducibility. All four labs exhibited low CVs for test repeatability and reproducibility for both the rotation and the moment, with one exception. At MGA, the variability in neck moments on serial no. 007 was slightly elevated (CV=5.9%) for the left aspect only. However, this elevation is mostly a function of the low moment generated by the test (only 9 Nm nominally), where variations as little as +/-1 Nm created a high CV. All moments were, in fact, within the prescribed, and narrow, 8-10 Nm range specified in the NPRM. The CVs for dummy reproducibility were universally low (below 6%) at all labs and for all dummies, and for both neck rotation and neck moment. In every trial, all dummies at all labs demonstrated a pass in accordance with the acceptance criteria of this final rule.

e. Lumbar Column

The Q3s's rubber lumbar column bends during a CRS side impact test. This bending can affect the overall kinematics of the dummy, including the excursion of the head. It can also affect lateral loads and the deflection of the thorax.

Lumbar qualification consists of two types of pendulum tests: a lateral test and a frontal test. For both tests, the lumbar spine element containing the flexible column is removed from the dummy, like the neck qualification tests. The lumbar tests use the same Part 572 swinging arm pendulum and the headform device used in the neck qualification tests. The headform is not

intended to represent the inertial properties of a body region as it is with the neck tests. Rather, it merely provides an apparatus that helps to ensure a repeatable test condition. The lumbar tests also use crushable aluminum honeycomb to attain a prescribed deceleration pulse.

In the case of the lumbar qualification, lateral and frontal tests are conducted at the same impact speed of 4.4 m/s and specify the same pendulum impulse. The rotation of the lumbar column, the lumbar moment, and the timing associated with the moment and rotation are set forth in this final rule.

The agency notes that the lumbar qualifications for lateral and frontal tests are almost identical. This is to be expected since the lumbar element is a circular cylinder constructed from an isotropic material (rubber), and so, theoretically, the directional properties should be the same for lateral vs. frontal bending. However, the agency has established two separate sets of acceptance criteria owing to possible dissimilarities brought on by the molding and bonding processes and asymmetries of inertial influences due to differences in the configuration of mounting plates and headform.

Further, the frontal flexion test helps assure that the metal-to-rubber bond of the lumbar is intact in a manner the lateral flexion test does not. This was demonstrated during the very last series of tests on NHTSA-owned serial no. 008 Q3s dummy, where NHTSA observed a slight separation after the first of five trials. The subsequent trials all produced a rotation failing the limits of the NPRM and the final rule, whereas lateral flexion tests performed on the damaged part resulted in passes. That is, the frontal test detected the tear in the part, whereas the lateral test did not.

Lateral Flexion

This test mimics the main bending direction of the Q3s's torso during a CRS side impact test as proposed in the FMVSS No. 213 upgrade. This test assures uniformity in such bending.

The NPRM proposed a maximum rotation of 47-59 degrees (11.3% of the midpoint). The maximum moment was proposed to be 78-97 Nm (10.9% of the midpoint).

This final rule sets the maximum rotation at 46.1-58.2 degrees (11.6% of the midpoint). The maximum moment is set at 79.4-98.1 Nm (10.5% of the midpoint).

Test R&R and Dummy Reproducibility. At all four labs, the CVs for test repeatability and test reproducibility were below 5% and 6%, respectively, for both the rotation and the moment with all dummies. For dummy reproducibility, however, the CVs were above 6% at two of the labs. Tests revealed that two of the newer units, the Britax-owned unit (tested at VRTC) and the MGA-owned (tested at MGA), produced greater rotations than the older NHTSA-owned units. As a result, the CVs for dummy reproducibility in lumbar rotation at VRTC and MGA were 6.5% and 7.4%, respectively.

All dummies at all labs were demonstrated to pass the qualification limits of this final rule. The margins for acceptance are essentially the same as those of the NPRM, but the midpoints for both rotation and moment have been shifted slightly downward for rotation and upward for moment.

Frontal Flexion

The proposed FMVSS No. 213 side impact test is carried out at a slight oblique angle. Typically, the torso of the Q3s bends laterally and slightly forward, so NHTSA has included a frontal (forward) component to the lumbar qualification.

The NPRM proposed a maximum rotation of 48-57 degrees (8.6% of the midpoint) in the NPRM. The maximum moment was proposed to be 78-94 Nm (9.3% of the midpoint).

This final rule sets the maximum rotation at 47.0-58.5 degrees (10.9% of the midpoint). NHTSA set the maximum moment at 78.2-96.2 Nm (10.3% of the midpoint).

Test R&R and Dummy Reproducibility. The CVs for test repeatability and reproducibility were under 5% and 6%, respectively, at all labs and all dummies for both rotation and moment. However, the new MGA-owned unit produced consistently higher rotations than the two NHTSA-owned units, resulting in a CV of 8.0% for reproducibility of the dummy's lumbar in rotation. At VRTC, the new Britax-owned unit had rotations that were also high, resulting in a CV dummy reproducibility score of 6.6%. At Calspan, its new unit produced consistently higher lumbar moments than the two NHTSA-owned units. Thus, the Calspan CV score for dummy reproducibility of the lumbar moment was elevated (7.7%).

All dummies at all labs were demonstrated to pass the qualification limits of this final rule. In setting the new limits, NHTSA has slightly widened the margins for acceptance relative to the NPRM for both rotation and moment to accommodate the newer units. In both instances, the margins are still under the 11% goal.

Timing Specifications Associated with Lumbar Qualification

All pendulum tests for the lumbar column have specifications on the time at which the maximum moment and maximum rotation occur. The agency has revised the way signal timing is assessed for the lumbar column and neck qualification tests and has slightly increased the time that it takes the lumbar column (or neck) to return from its position at peak rotation to the position of zero rotation. The discussion of those issues can be found in the section below.

Timing Specifications Associated with Neck and Lumbar Qualification⁴⁶

1. Maximum Moment and Rotation

⁴⁶ The following discussion also applies to the timing specifications for the lumbar column qualification tests.

All pendulum tests for the neck and lumbar column place specifications on the time at which the maximum moment and maximum rotation occur. This final rule revises the way signal timing is assessed.

The test data indicate that the proposed time specifications were generally met. There were only a few instances where the peak time was just under or just over the prescribed interval. All the tests would have met the time specifications if the intervals were expanded by just 1 ms, except for the time specification for the maximum moment in the neck lateral flexion test (see Table 8 below). Here, 60 trials (about half of all trials) were below the NPRM lower limit. However, for this test, the range of allowable times was only a 7 ms interval, whereas the intervals in the other four tests ranged from 11 to 20 ms.

The 7 ms time interval was very narrow because, along with all qualification intervals proposed in the NPRM, it was derived solely from the statistics of the then-available test data. The interval of 7 ms represented three standard deviations from the mean of data gathered during the NPRM stage. The very narrow time interval was the result of running the tests at a single lab (VRTC) under highly similar impulses and using aluminum honeycomb from a common lot.

Table 8. NPRM time specifications for neck and lumbar qualification tests

Qualification Test	NPRM time specifications		No. of trials with a time that differed from the NPRM time specifications	
	Max Rotation	Max. Moment	Max. Rotation	Max Moment
Neck frontal flexion	55-63 ms	49-62 ms	1	0
Neck lateral flexion	65-72 ms	66-73 ms	0	60
Neck torsion	91-113 ms	85-105 ms	0	2
Lumbar frontal flexion	52-59 ms	46-57 ms	2	1
Lumbar lateral flexion	50-59 ms	46-57 ms	0	1

The agency's latest pooling of test data reveals that the timing disparity in the neck lateral flexion test is related to lab-to-lab variability, not to test repeatability or dummy repeatability.

For any given lab, the times are clustered within a very narrow interval of about 6 ms for all trials of all dummies tested at that lab. Thus, the timing discrepancy appears to be related to the test protocol, not dummy reproducibility.

Time specifications in final rule. NHTSA could have expanded this interval by 6 ms (which would have put it in line with the other intervals in Part 572), which would have resulted in a pass for all trials. However, rather than adjusting the NPRM time interval in that way, the agency has adjusted the way signal timing is assessed. For the final rule, the agency has adopted the same performance specification that is used for other Part 572 child dummies (Subpart N - HIII-6C; Subpart P – HIII-3C; Subpart T – HIII-10C).⁴⁷ Instead of using time $t=0$ as a reference for the maximum moment, the final rule specifies a range for the peak moment during the time interval when the rotation is above a specified limit. For neck flexion, the regulatory text specifies that Plane D, referenced in Figure W3 of Part 572, shall rotate in the direction of pre-impact flight with respect to the pendulum's longitudinal centerline between 69.5 degrees and 81.0 degrees and that, during the time interval while the rotation is within these angles, the peak moment measured by the neck transducer shall have a value between 41.5 N-m and 50.7 N-m.

Similar wording is used for the neck lateral, neck torsion, lumbar frontal, and lumbar lateral tests. All dummies passed the time specifications at all labs in all trials using this approach.

This revised specification for the timing is better than what was proposed in the NPRM because lab technicians following the procedure would not have to pinpoint $t=0$ as specified in the NPRM. In the NPRM, time $t=0$ is defined as: "All instrumentation data channels are defined to be zero when the longitudinal centerline of the neck and pendulum are parallel." In

⁴⁷ Subpart N, Six-Year-Old Child Test Dummy, Beta Version (HIII-6C); Subpart P, Hybrid III 3-Year-Old Child Crash Test Dummy, Alpha Version (HIII-3C); Subpart T, Hybrid III 10-Year-Old Child Test Dummy (HIII-10C).

practice, determining the instant at which the parallel alignment occurs can be challenging, and has a significant bearing on a pass vs. fail outcome (as shown by the post-NPRM data, where it was not unusual that a pass vs. fail outcome was determined by less than 1 ms). Referencing a particular data point (the point of maximum rotation) identifies the reference time with greater precision.

2. Decay Times

The specification for decay time specifies the time that it takes the neck or lumbar column to return from its position at peak rotation to the position of zero rotation. This specification is included in all other Part 572 dummies mentioned previously. It serves to assure uniformity of the hyperelastic material used to construct the neck (or lumbar column). It also ensures that the later part of the impulse brought on by the collapse of the aluminum honeycomb structure is uniform.

The NPRM proposed decay times listed below in Table 9. In about 15% of the post-NPRM trials, the NPRM decay times were not met for neck and lumbar frontal flexion. Expanding the NPRM decay interval by only a few milliseconds results in PASS in all trials for all dummies at all labs.

Table 9. Q3s moment decay times for neck and lumbar qualification tests

Test	NPRM decay time, ms	Final rule decay time, ms	No. of trials that differed from the NPRM decay time specifications
Neck frontal flexion	50-54	45-55	10
Neck lateral flexion	63-69	61-71	0
Neck torsion	84-103	85-102	0
Lumbar frontal flexion	50-56	49-59	11
Lumbar lateral flexion	47-59	48-59	0

Decay time in final rule. The decay intervals for the final rule are listed in Table 9. In qualification tests for other Part 572 dummies, the intervals for neck decay times ranged from 10 to 35 ms. NHTSA considers 10 ms a practical lower limit on the interval, accounting for the precision of the measurement system of any given lab. Thus, the decay times have been adjusted so that the intervals are no narrower than 10 ms. With these time intervals, all dummies met the decay time interval at all labs in all trials.

f. Shoulder

This test assures that the shoulder acts uniformly in the way it deforms under load and distributes the load under a lateral impact during CRS testing, thus helping to ensure that whole-body kinematics are consistent.

Shoulder qualification is accomplished with a lateral impact to the shoulder using a 3.8 kg probe at an impact speed of 3.6 m/s. Conformity is based on the maximum probe force and the maximum deflection of the shoulder, as measured by a potentiometer installed within the dummy.

The NPRM proposed that the peak probe force must be 1240-1350 N (4.3% of the midpoint), and that maximum displacement of the shoulder must be 16-21 mm (13.5% of the midpoint).

This final rule sets the peak probe force to be 1123-1437 N (12.3% of the midpoint). Maximum shoulder displacement is 17.0-22.0 mm (12.8% of the midpoint).

Test R&R and Dummy Reproducibility. The CVs for test repeatability and reproducibility were below 5% and 6%, respectively, for the measurements of probe force and shoulder displacement with all dummies at all labs.

However, compared to the other three labs, the probe forces in tests at HIS were consistently higher for the newer dummies, whereas for the older NHTSA units, test repeatability at HIS had noticeably more scatter. This trend may have been related to arm positioning. During the latest testing series, NHTSA realized that, contrary to the agency's intent, the Q3s's upper arm can meet the position setting described in the NPRM in both medial/lateral rotation and in ab/adduction. In other words, the NPRM did not specify a unique position for the upper arm. To address this, in the final rule, there are more instructions in the dummy positioning procedure for the shoulder test as to where to position the Q3s's elbows and arms. This simple step should result in better R&R of the qualification test.

The CV for dummy reproducibility of the shoulder force was elevated in three of the assessments (ranging from 6.1% to 7.8%). Two of the newer units – 5860 owned by MGA and 059 owned by Calspan – were different from the others in that they produced lower probe forces, particularly for the left aspect. This has resulted in slightly expanded qualification limits for the shoulder.

While the limits for probe force have been widened, the midpoint is essentially the same. At 12.3%, the limits are now wider than the 11% goal, but still considerably narrower than those of other Part 572 side impact dummies (the limits for the ES-2re and SID-IIIsD are both 16%).⁴⁸ Also, there is no immediate injury reference value directly related to the shoulder in the proposed FMVSS No. 213 side impact test, so its uniformity is less important.

For shoulder deflection, the range of the limits is essentially the same as those of the NPRM, but they have been shifted upward to allow greater deflection. NHTSA considers this an

⁴⁸ The NPRM limits for probe force were at 4.2%, but they were unusually narrow, even considering that all data was gathered at a single lab (VRTC). There is no limit narrower than 5% for any Part 572 qualification requirement (displacement or otherwise).

improvement to the specification. From a biofidelity standpoint, the shoulder is stiff relative to a human. Shifting the deflection limits upward (rather than downward) is consistent with a more biofidelic response. The 12.8% shoulder deflection limits sound relatively wide, but are not of concern because they are a function of the low level of deflection seen in the test (only 17-22 mm). This 5 mm interval is lower than that of any deflection-based limit of any other Part 572 dummy (several dummies have limits with 6 mm intervals).

Almost all dummies at all labs met the probe force and shoulder displacement criteria of this final rule. The only exception was with the probe force on the left aspect of the MGA unit. In all trials run at MGA, the force was well below the qualification limits, so it is possible the dummy may need some remedial work, e.g., a part replacement or some other fix. On the other hand, the dummy's response was well-centered between the limits in trials at HIS, so the MGA results could have resulted from a problem with the test set up or position of the arm.

g. Thorax

The response of the thorax under lateral loading is a high-priority performance target for the Q3s because thorax deflection is an injury reference measurement in the proposed FMVSS No. 213 side impact test. Qualification of the thorax is carried out under two separate conditions: without arm interaction (a test probe strikes the thorax directly); and with the arm in place (with the elbow lowered so that the probe strikes the upper arm).

Thorax Without Arm

The "thorax without arm" test assures uniformity of the thorax structure, including its mount to the spine, and its response to a direct impact in terms of rib deflection. For this test, the arm is completely removed from the dummy. The test is carried out by striking the dummy on the lateral aspect of the thorax with a 3.8 kg probe at a speed of 3.3 m/s. Conformity is based on

the probe force and the thorax displacement as measured by an IR-TRACC⁴⁹ mounted within the dummy's chest cavity.

The NPRM proposed that the peak probe force must be 620-770 N (10.8% of the midpoint). The maximum displacement of the thorax was proposed to be 24-31 mm (12.7% of the midpoint).

This final rule sets the peak probe force to be 610-754 N (10.6% of the midpoint). Maximum thorax displacement is 24.5-30.5 mm (10.9% of the midpoint).

Test R&R and Dummy Reproducibility. The CVs for test repeatability and reproducibility were all below 5% and 6%, respectively, for the measurements of probe force and thorax displacement with all dummies at all labs. However, several of the CVs for dummy reproducibility were between 6% and 10%. The data showed that the new MGA and Britax units were stiffer than the other ATDs, resulting in higher probe forces and lower thorax displacements than the other dummies.

The high stiffness in the newer units is a major concern for NHTSA. Throughout the development cycle of the Q3s, the agency has stressed the importance of lateral thorax biofidelity.

In the NPRM, NHTSA demonstrated that thorax biofidelity was assessed through a series of pendulum impacts prescribed by SAE International. The probe force was used to assess the external biofidelity of the thorax, and upper torso (T1) acceleration was used to assess internal

⁴⁹ The Infra Red Telescoping Rod for Assessment of Chest Compression (IR-TRACC) is a device that measures deflection. It was developed by General Motors and is manufactured by HIS. NHTSA knows of no other suppliers of this device. On the other hand, there are no patents or restrictions that would prevent another company from manufacturing the device. Further, although the final rule specifically calls out the IR-TRACC, NHTSA would consider an amendment in the future to specify the use of an alternative device if one were developed that could sufficiently measure the thorax deflection as the IR-TRACC does. At this time no such device has been developed.

biofidelity. The tests showed that the units that NHTSA used to develop the NPRM (which included serial nos. 004, 006, 007, and 008) all performed very close to the biofidelity targets.

Given the thorax results with the MGA and Britax units, it was important to assess their performance against the biofidelity targets. NHTSA re-ran the biofidelity tests on two units: an older NHTSA-owned unit (serial no. 007) and the new, stiffer unit, the MGA-owned serial no. 5860. The tests on serial no. 007 served as a benchmark and again showed that it performed very much like it had during the NPRM stage (i.e., close to the biofidelity targets). On the other hand, serial no. 5860 (the MGA unit) was barely within the margins for acceptable biofidelity. It exhibited elevated T1 acceleration and straddled the upper corridor of the target for the probe force but stayed within the corridor.

For the final rule, NHTSA formulated the acceptance criteria for the qualification test so that they stayed under the 11% goal for qualification limits. The nominal response of the MGA unit served as the upper limit since it met the biofidelity corridor. All responses generated in tests of the Britax unit fell outside the qualification limits, however. The probe responses in the Britax tests were well above the final upper qualification limit at both labs where it was tested (HIS and VRTC) for all trials, both right and left. It is also noted that the Britax unit's deflection was on the lower border of the final qualification limit for thorax deflection. The results of tests of the newer Britax unit show that its thorax was much too stiff. NHTSA considered this thorax substandard. In formulating the probe force limits for the thorax without arm test, the data from the Britax unit is not within the acceptance criteria.⁵⁰

Thorax With Arm

⁵⁰ Some already-purchased newer Q3s dummies in the field might have the overly stiff thorax. Users may have to remedy the part to pass the thorax without arm test.

The “thorax with arm” test loads the ribcage through the upper arm. It assures uniformity of the arm in the way the arm absorbs energy and interacts with the thorax in a lateral impact.

This test is carried out with the elbow lowered and the upper arm aligned with the dummy’s thorax. The lower arm is positioned to make a 90° angle with the upper arm. (For this final rule, the added stipulation for upper arm positioning (discussed earlier in conjunction with the shoulder test) will be used in this test too, to help labs attain the specified response.)

The position of the 3.8 kg probe relative to the thorax is the same as in the “thorax without arm” test (the same probe is used as well). However, the impact speed of the probe for this “thorax with arm” test is 5.0 m/s (vs. 3.3 m/s). Conformity is again based on the probe force and the IR-TRACC’s measure of thorax displacement.

The NPRM proposed that the peak probe force must be 1380-1690 N (10.1% of the midpoint). The maximum displacement of the thorax was proposed to be 23-28 mm (9.8% of the midpoint).

This final rule sets the peak probe force to be 1360-1695 N (11.0% of the midpoint). Maximum thorax displacement is 22.5-27.5 mm (10.0% of the midpoint).

Test R&R and Dummy Reproducibility. The CVs for test repeatability were below 5% for all assessments except one. At HIS, four separate repeatability assessments were scored based on tests with two NHTSA-owned units, serial nos. 004 and 007, with separate scores for right-side and left-side impacts. Three of the four produced CV scores below 5%. The fourth (on serial no. 007, right side) produced an elevated CV score of 9.3%, which was driven upward by greatly elevated probe forces in two of the six trials. HIS did not provide an explanation for the elevated force levels.

The CV for test reproducibility was below 6% in all instances except, again, for the probe force on the right side of serial no. 007. A CV score of 7.4% was driven upward by the same two trials discussed above. Without the two, the CV was 4.3%.

Dummy reproducibility ratings were elevated for this test (individual lab scores ranged from $11\% < CV \leq 15\%$). NHTSA's assessment revealed scatter in the measurement of probe force among the newer Q3s units. The lowest forces were generated by the Calspan-owned unit while the Britax-owned unit produced consistently high forces. Probe forces in trials with the MGA-owned unit were between those produced with the Calspan-owned and Britax-owned units, and in line with the older NHTSA-owned units.

The final qualification limits for the thorax displacement are essentially the same as those of the NPRM. At these limits (10% of the midpoint), all dummies were demonstrated to pass at all labs. NHTSA considers the acceptance interval of 5 mm (for the 22.5-27.5 mm limit) to be tight. As described earlier for the shoulder qualification (which also has a 5 mm interval), no other Part 572 interval is less than 6 mm.

For the probe force, the final limits (1360-1695 N) have been expanded slightly from those of the NPRM (10.1% to 11%). However, they have been restricted to the 11% goal since the stiffness of the lateral aspect of the dummy can influence its interaction with a CRS in a side impact test.

This test has screened out some Q3s units from qualifying. Calspan could not qualify serial no. 059 (its own unit). All trials produced probe forces well below the 1360 N limit. The Britax-owned unit straddled the upper limit of 1695 N. The added stipulation for upper arm positioning should be beneficial in helping attain the specified response.

h. Pelvis

This test helps assure uniformity in the way the pelvis loads a CRS during a side impact test. The qualification test is carried out by striking the lateral aspect of the pelvis (near the hip) with a 3.8 kg probe at 4.0 m/s. (The probe is the same as that used in the shoulder and thorax qualifications.)

Conformity is based on the force measured by the impacting probe. The NPRM proposed that the peak probe force must be 1575-1810 N (7.1% of the midpoint). This final rule sets the peak probe force at 1587-1901 N (9.0% of the midpoint).

The NPRM had also proposed to limit the peak pubic load measured by a load cell within the dummy. The NPRM proposed that the peak pubic load be between 700-870 N (10.8% of the midpoint). As explained below, on further consideration, NHTSA has not adopted the pubic load criterion.

Test R&R and Dummy Reproducibility. For the probe force, the CVs for test repeatability were below 5% for all assessments at all labs. Essentially all dummies at all labs were demonstrated to pass the probe force limit. The only exception was with the right aspect of the serial no. 008 dummy, a NHTSA-owned unit. While in all trials run on this dummy at MGA the force was well below the lower qualification limit for probe force, the response for this dummy was well centered between the limits in trials at VRTC and Calspan. Thus, there may have been a test set up anomaly at MGA on serial no. 008, and the low forces caused two instances of elevated CVs for test reproducibility (7.6%) and dummy reproducibility (6.7%).

For the pubic load measurement, the CVs for test reproducibility and dummy reproducibility were mostly above 6% and as high as 15%. NHTSA analyzed the data and found sources for the variability in both the test procedure and in differences among the dummies.

The undesirable test reproducibility rating is most likely a consequence of striking the dummy at the hip over the ball and socket joint that joins the femur to the pelvis. The force generated by the probe is transmitted to the pubic load cell through this joint only. Since a ball joint exerts no reaction moments to restrict rotation, even if the dummy and probe are lined up precisely in the pre-test set up, upon impact there is little to control the rotation of the femur relative to the pelvis. Thus, the reaction force in the direction of the pubic load cell will have a relatively high degree of variability from one test set up to the next.

Further, differences in the construction of the dummy most likely exacerbated the variability related to striking the ball and socket joint. The test probe contacts the dummy on the surface of the femur, which is made largely of urethane and plastic. The femur bone itself is a plastic part (with a steel reinforcement) embedded within a thick molding consisting of urethane foam covered by a polyvinyl chloride (PVC) skin. By their very nature, these parts require much larger dimensional tolerances than metal parts and they have a much more variable response to impact. Furthermore, the relationship between the point of impact on the femur skin and the center of the femur head is loosely controlled (there is no dimensional requirement for this relationship on the engineering drawings).

Due to the elevated degree of variability associated with the pubic load, NHTSA has decided not to adopt the pubic load criterion in the final rule.⁵¹ Uniformity in the pubic load is not a necessary qualification since it is not associated with any proposed injury assessment reference value in the FMVSS No. 213 rulemaking. Further, probe force—which NHTSA is adopting as a qualification—is a better measure of dummy loading to the child restraint system, which is the primary concern for the pelvis.

⁵¹ By removing the pubic load requirement, the pubic load cell is no longer necessary and a “blank” structural replacement may be installed in its place.

VII. Response to Comments (Part II) on the Acceptance Criteria and Test Procedures for the Qualification Tests

In this section, NHTSA responds to comments on specific aspects of the acceptance criteria and test procedures used for the qualification tests.

a. Head Qualification

Comment Received

Dorel stated that HIC signal data are not available to them for further analysis. Dorel also believed that the proposed limits of acceptability, 113-140 Gs for lateral acceleration, allow too wide of an acceptance band, thus creating what the commenter said was the potential for a high degree of HIC variability in CRS compliance testing.

NHTSA Response

NHTSA has provided data tables and plots of dummy instrumentation signals within supporting reports referenced in this final rule and in the NPRM.⁵² The qualification report describes a series of sled tests with two Q3s units, serial nos. 006 and 007, in which each unit was tested five times in left side impacts under otherwise identical conditions. In these tests, the average HIC value was 700.4 with a CV of 2.4%.

In contemporary head qualification tests on the left aspect of these same units (five trials each), the CV of the resultant head acceleration was 2.97%, which is slightly greater than the HIC variability observed in sled tests. Therefore, in any future repeat testing of a particular CRS with multiple Q3s units, the variability seen in HIC values caused by slightly different dummy heads is expected to be no more than the variability allowed by the qualification limits of +/-

⁵² See “NHTSA’s Q3s Qualification Testing, 2014-2015, May 2016,” in the docket for this final rule. The agency also generally provides qualification plots in NHTSA’s compliance test reports for CRS testing. These reports are available for the public to download.

10.2%. NHTSA views this level of variability as representative of a reasonable design margin. For example, to assure that $HIC_{15}=570$ is not exceeded,⁵³ a manufacturer may need to design their CRS to achieve an average HIC value of only $HIC_{15}=517$. This accounts for a possible outcome that might be 10.2% higher if a test is run with any other Q3s unit.

Thus, the agency does not agree there is a potential for a high degree of HIC variability in compliance testing. Furthermore, in the final rule, the limits on the resultant head acceleration in the lateral head drop test narrowed slightly (114-140 Gs) from those proposed in the NPRM (113-140 Gs). As discussed above, NHTSA has also narrowed the allowable off-axis acceleration to +/- 15 Gs from +/- 20 Gs in the NPRM. This change has a positive effect on assuring head uniformity in a lateral impact.

As stated earlier, the qualification limits of 114-140 Gs assure a sufficiently high level of uniformity in the responses of replicate dummies without being unreasonably hard for test labs to attain. The limits are also consistent with other Part 572 dummies as shown previously (see Table 7).

Comment Received

Dorel commented on the data produced by the head drop tests and the duration of the impact event. It noted a variation in the duration of the acceleration of about 12% from the mean among the four heads that the agency tested. By showing that the duration of the acceleration seen in NHTSA's head qualification tests varies, Dorel surmised that the dummy head may produce variance in HIC that is unacceptably wide.

NHTSA Response

⁵³ Note that $HIC_{15}=570$ is the pass/fail reference value proposed for the Q3s in NHTSA's NPRM to upgrade FMVSS No. 213 (see 79 FR 4570). It is also the pass/fail reference value for the Hybrid III 3-year-old dummy when assessing the deployment of air bags in FMVSS No. 208, "Occupant crash protection."

With regard to the duration of the impact event, the NPRM did not set a specification for the duration of the head drop acceleration, and no such specification exists for any other dummy within Part 572. Such a specification is not needed because the shape of the acceleration response produced by the head drop test is highly uniform among all heads. Also, the input energy changes very little from test to test because drop height and head mass are controlled tightly. Thus, a head acceleration response of lower magnitude will be longer in duration owing to energy conservation laws. Qualification is therefore based only on the magnitude of the head acceleration response; otherwise, the system would be over-constrained.

The head qualification test protocols (both for lateral and frontal) do not impose a rigorous time = 0 setting. Instead, the tests are meant only to record the peak amplitude of acceleration. Also, since there is no specification for the duration of the acceleration pulse, there is no definitive protocol to set time = 0. To impose such a specification could unnecessarily compromise the integrity of the main purpose of the test itself (to objectively measure head acceleration) because the means to pinpoint time = 0 (such as a contact electrode placed on the rigid impact plate at the point of contact with the head) could influence the response of the head.

Comment Received

For the Q3s head drop tests, the NPRM regulatory text proposed an ambient temperature range of 18.9 to 25.6 degrees Celsius (C). This range is wider than what is specified for other Part 572 dummies, and is wider than what was specified in the agency's support document, "Qualification Procedures for the Q3s Child Side Impact Crash Test Dummy," which was docketed with the NPRM. The latter specifies a range of 20.5 to 22.2 degrees C, which is consistent with other Part 572 dummies.

HIS commented that the ambient temperature should be 20.5 to 22.2 degrees C, noting that HIS has not tested Q3s head assemblies within the larger temperature range and does not know how that temperature may affect the performance of the head.

NHTSA Response

NHTSA agrees with this comment, as the wider temperature range was in error. For this final rule, the range is specified as 20.5-22.2 degrees C in accordance with NHTSA's support document. The agency further notes that its Q3s testing has all been carried out within the tighter temperature range.

b. Neck Qualification

Comment Received

HIS seeks clarification on whether the headform rotation calculation is performed on the filtered angular rate data or whether the computation should be filtered after the integration. HIS suggests clarifying the regulatory text on this matter.

NHTSA Response

The outputs of the transducers were specified in the NPRM regulatory text, §572.219, *Test conditions and instrumentation*. For the pendulum angular rate sensor, channel frequency class (CFC) 60 is specified. Thus, the rotation calculation is performed on an angular rate sensor (ARS) signal that is already filtered to CFC 60. No changes in the final rule are needed to address this point.

Comment Received

HIS notes that the NPRM's impact velocity in the lateral neck flexion is specified with a tolerance of ± 0.05 m/s, whereas all the other Q3s qualification tests have a velocity tolerance of

± 0.1 m/s. HIS believes the tighter tolerance will be difficult to maintain and measure. It recommends a tolerance of ± 0.1 m/s for all tests, including the lateral neck pendulum test.

NHTSA Response

The tighter tolerance proposed in the NPRM was in error. For this final rule, NHTSA has revised the proposed regulatory text to indicate a tolerance of ± 0.1 m/s for the impact velocity in the lateral neck pendulum test, as suggested by HIS. The correct specification for velocity is 3.8 ± 0.1 m/s. NHTSA has also corrected a minor error in the support document, “Qualification Procedures for the Q3s Child Side Impact Crash Test Dummy,” which incorrectly specifies the impact velocity in the fore-aft neck flexion test as 4.7 - 4.8 m/s. The correct specification for fore-aft velocity is 4.7 ± 0.1 m/s.

Comment Received

HIS requested NHTSA clarify Figure W4 in the NPRM, which depicts the assembly for the lateral neck flexion test. A set-up for a right flexion test is shown. The regulatory text states that the set-up for a left flexion test would be a mirror image of Figure W4. Figure W4 shows the approximate location of an ARS mounted on the pendulum interface block. Whereas the entire assembly is designed so that the neck may be flip-mounted for either a right or a left test, the interface block itself may remain bolted to the pendulum for both tests; i.e., neither it nor the ARS attached to it need to be flipped. HIS asked NHTSA to clarify this in the final rule.

NHTSA Response

NHTSA agrees that flipping the position of the ARS is not necessary for right vs. left tests. NHTSA clarified this in the final rule regulatory text for §572.213(c)(2)(ii) by stating that the mirror image would include all components beneath the pendulum interface plate in Figure W4.

The agency notes that the same situation exists for the lateral lumbar test depicted in Figure W10. NHTSA has made the same clarification to §572.217(c)(2)(ii).

Comment Received

For the neck torsion test, HIS noted that the NPRM regulatory text provides two definitions as to when the data channels are to be zeroed. The first time occurs prior to running the test and requires collecting a data point for each channel during the setup of the test. The second time is when the pendulum makes contact with the striker plate. This occurs during the test and would require identifying where (in the data set) time zero occurs, recording the value of each data channel at that point, and then subtracting that value from corresponding data set for each channel. HIS noted that processing the data under each definition would result in different outputs for each channel. HIS recommends that a single method for "zero definition" should be established for processing the data.

NHTSA Response

The NPRM contained an error. Zeroing of data channels occurs only once, at the step when the zero pins are installed. For this final rule, §572.213 (b)(3)(iv) has been corrected by removing the last sentence that had stated: "All data channels shall be at the zero level at this time."

c. Arm Position

Comments Received

Several comments on the NPRM for the proposed FMVSS No. 213 side impact test suggested that NHTSA should specify an exact position of the dummy's arm during testing. According to Graco and TRL, the initial arm position has a significant effect on the chest compression measurement in FMVSS No. 213 side impact tests. TRL also noted that when the

Q3 dummy⁵⁴ (similar to the Q3s) is used in side impact tests specified in the European CRS regulation (UNECE Reg. No. 129, “Enhanced child restraint systems,”), its arm position also influences test results.

NHTSA Response

NHTSA agrees that the Q3s’s arm position influences chest deflection in impacts to the side of the torso. The agency recognized this prior to the Part 572 and FMVSS No. 213 proposals, so NHTSA assured that the Q3s shoulder design included a ball detent within the shoulder joint to aid in setting the arm precisely. The detent was specified in the NPRM version of the dummy and has been retained in the version specified for this final rule. To further address this issue, in this final rule there are more instructions in the dummy positioning procedure as to where to position the Q3s’s elbows and arms. NHTSA will address positioning the Q3s’s arm in the FMVSS No. 213 side impact test, as appropriate.

VIII. Post-NPRM Data from Humanetics

a. Qualification Tests

On February 9, 2016, HIS submitted a data spreadsheet to the NPRM docket that contains qualification results for Q3s units that they built and tested between 2013 and 2015. The spreadsheet includes the data on the units sold to Britax, MGA, and Calspan which had been obtained by NHTSA independently from the dummy owners and is already included in our analysis as explained earlier. HIS’s spreadsheet also contains data for seven other units (owners not disclosed) that NHTSA had not obtained.

⁵⁴ The Q3 is one of a group of dummies known as the Q-series used in the European CRS regulation (UNECE Reg. No. 129) in frontal, side, and rear impact tests. Both the Q3s and the Q3 represent a three-year-old and are very similar in their construction and appearance. However, the Q3s is designed for side impacts only. Differences and similarities between the two dummies are covered in the NPRM in greater detail.

In addition to providing the data itself, HIS recommended limits for each qualification requirement based on the means of their measurements contained within their spreadsheet, plus/minus two standard deviations. In computing standard deviations, each trial carried an equal weight. However, there were uneven numbers of trials (over ten trials for some units and three or less for many others), which gave greater weight to the responses of particular dummies. Furthermore, HIS stated that they removed extreme data outliers, redundant tests, and lab-to-lab variation tests from the dataset. No further information was given on how many tests were excluded or the criteria for determining outliers, and no explanation was given on why redundant tests (which are needed to assess repeatability) were removed. Thus, the standard deviations derived from the HIS dataset have limited interpretive value.

All tests on the seven additional units appear to have been performed at HIS. Since we do not have data on the seven units from other laboratories, which is needed to fully evaluate repeatability and reproducibility, the data contained within the spreadsheet are not included in our overall assessment of R/R described earlier. Nonetheless, we examined HIS's data for the seven additional units to compare them against the data that we collected.

All qualification test requirements were examined against the additional HIS data with the exception of the timing requirements for the neck and lumbar moments and the pubic force requirement. The final rule specifies that the peak moment must occur during the time interval in which the rotation is within a specified set of rotation angles. We could not deduce whether the seven units conformed to the final rule because time-history data was not provided by HIS. We excluded the pubic force requirement since it has been dropped from the Final Rule.

We limited our examination of HIS's data to trials that were inclusive of HIS's recommended limits. We did this to examine the degree to which the seven new units are

acceptable by both HIS's standards and the final rule. (About 5% of the trials listed in the HIS submission had responses that were more than two standard deviations away from the mean response. We did not include those data points.) We counted how many HIS trials had responses that were outside the limits specified by the final rule.

In three of the qualification tests, the "Head, Frontal" test, the "Thorax without Arm" test, and the "Thorax with Arm" test, a trend was seen in which multiple Q3s units did not conform to the final rule in 25% or more of test trials. These instances are shown in bold in the Table 10. This trend is consistent with our analysis presented earlier in which we determined that the thorax was too stiff and the resultant acceleration of the head was too low (in the frontal head drop test only) on some of the newer units.

Table 10. Final rule vs. HIS's data posting of February 9, 2016. Qualification tests in which two or more Q3s units failed to meet a requirement in 25% of their test trials.¹

Qualification test	Final Rule Requirement	Q3s Dummy Serial Number						
		0229	9558	2313	7218	9526	2244	5579
Head, Frontal	Res. Accel, 255-300 G	0 of 3	2 of 3	1 of 3	2 of 2	10 of 10	4 of 4	1 of 2
Thorax without Arm	Probe force, 610-754 N	7 of 7	3 of 6	4 of 4	2 of 7	3 of 12	5 of 7	0 of 4
	Thorax displacement, 24.5-30.5 mm	1 of 7	0 of 6	2 of 4	2 of 7	3 of 12	0 of 7	0 of 4
Thorax with Arm	Thorax Displacement, 22.5-27.5 mm	3 of 6	0 of 4	0 of 12	0 of 4	0 of 17	0 of 5	1 of 4

¹Interpretation. For s/n 9558 in Head, Frontal test: "2 of 3" indicates two trials (of a total of three) produced a resultant acceleration outside the range of 255-300 G range specified by the Final Rule. The bold, italics entry indicates a ratio $\geq 25\%$ of nonconforming trials to total trials.

As mentioned earlier in this preamble, owners of new units may need to take remedial action to improve the responses of their dummies in the frontal head drop test and the thorax impact tests. HIS's data on all other qualification tests shows that the seven additional units are

consistent with the dummy responses observed in our analysis presented earlier. With the exception of the instances shown in Table 10, HIS's new dummies are all aligned within the qualification response limits specified by the final rule. The non-conforming dummy responses shown in Table 10 are discussed in more detail below.

Head, frontal: Resultant head acceleration. The heads of six of the seven new units registered acceleration levels below the lower limit of 255 Gs specified in the final rule. HIS also provided test results on several spare heads (not associated with a particular dummy). For each of those heads, the acceleration levels were under 255 Gs in half or more of their respective test trials (about 240 G on average). These levels were also below the NPRM lower limit of 250 G, which was the minimum target response at the time the heads were tested.

This condition is similar to that of the MGA head described in the NHTSA analysis presented earlier. Recalling that 255 Gs coincides with the lower limit of an acceptable biofidelic response, we demonstrated that the response of the MGA head was unacceptably low (non-biofidelic). Likewise, three of the new heads appear to be unacceptable since their responses were well below 255 Gs in all of their trials. Most of the other new heads had responses that were borderline unacceptable with average responses close to 255 Gs. Owners of these units may need to take remedial action in order to have dummy heads that would meet today's final rule.

HIS did not provide a rationale on why they were unable to attain the target response interval of the NPRM, though they did suggest that a lower target for a new unit is needed to account for material aging. According to their analysis, the response of a head that was newly manufactured in 2008 increased by 10% over a period of six years, which they presumed was due to aging. However, the upper response limit in the final rule is 300 G, which represents an

18% increase above the lower limit of 255 G. HIS did not demonstrate that an even lower limit is needed to account for aging.

Notably, one new unit, serial no. 0229, was within the limits for all trials (an average of 269 G over three trials). An HIS spare head also produced an acceptable response in its only trial (271 G). This demonstrates that it is possible to manufacture new dummy heads that consistently produce acceleration responses above 255 G. With regard to a possible aging effect, even if the responses of these units increased by 10% they would still be below the upper limit of 300 G.

Thorax without Arm: Probe force and Thorax displacement. For six of the seven new units, the probe force exceeded the Final Rule's upper limit and the thorax deflection was borderline in the majority of test trials. (The averages of the seven units were 766 N for force and 25.8 mm for displacement, and the intervals in the Final Rule are 610-754 N and 24.5-30.5 mm).

Two units in particular, serial nos. 0229 and 2313, exceeded the upper force limit in all trials. The average force levels for these two units (775 N and 813 N, respectively) also exceeded the NPRM range (620-770 N), which was the target response interval at the time the dummies were tested. HIS did not provide a rationale on why they were unable to attain the target response. Typically, a trial exhibiting a high force produces a low deflection, indicating that the thorax is too stiff. In HIS's data, this was the case for any trial in which the probe force exceeded the upper limit specified by the final rule.

This condition was also the case for the Britax unit presented earlier in our analysis in which we highlighted the importance of thorax stiffness to the overall acceptability of the dummy. We demonstrated that the newer Britax unit was much too stiff and well outside the biofidelity corridors. Serial nos. 0229 and 2313 also appear to be too stiff. Owners of these two

units, and perhaps four of the others, may need to remedy their dummies to reduce the thorax stiffness.

Notably, one unit, serial no. 5579, was within the limits for force and displacement in all trials. Also, serial no. 9526 was fitted with two separate thorax assemblies, one of which was also within the limits for all of its trials. This demonstrates that a given dummy may be manufactured or remedied with a thorax having a stiffness within the biomechanical and qualification limits.

Thorax with Arm: Lateral displacement. This test is designed to assure uniformity of the arm. However, the stiffness of the thorax (which is evaluated by the “Thorax without Arm” test) does influence the dummy response. For the “Thorax with Arm” test, six of the seven new units responded within the final rule’s limits for lateral displacement in the majority of their trials. However, one unit, serial no. 0229, exceeded the upper limit for displacement in half of its trials. But since the thorax of this unit was determined to be too stiff (as seen in the “Thorax without Arm” test data), we do not consider its performance in the “Thorax with Arm” test to be a valid criterion for setting the qualification limits.

b. Mass and Anthropometry Measurements.

HIS’s posting on February 9, 2016, also contained anthropometry and body segment mass measurements for the additional pool of dummies. These measurements were considered by NHTSA and the final rule has been revised accordingly. This is discussed further in Section IX, Drawing Package and PADI, under the heading of *Mass and anthropometry*. In all cases, the dummy measurements provided by HIS for anthropometry and mass are within the tolerances prescribed by the final rule.

IX. Drawing Package and PADI

Engineering Drawings

For this final rule, NHTSA has revised some of the engineering drawings to address discrepancies between the PADI and the engineering drawings, and some inconsistencies HIS noticed in the drawings it provided NHTSA for development of the NPRM. The changes either correct errors or provide missing information. They are not alterations that would change the dummy in any meaningful way or alter the dummy's response in either pre-test qualification testing or dynamic sled testing with CRSs. A comprehensive listing of changes is described in the document, "Q3s Engineering Drawing Changes, Rev. J, May 2016," *supra*, a copy of which can be found in the docket for this final rule.

Neck assembly revision to aid end-users. In the NPRM, the engineering drawings for the neck cable inadvertently allowed interference to occur with the lower neck load cell during the assembly of the head and neck (see drawing 020-2415, cable length = 81.3 mm). In the case of the Calspan-owned unit, the cable extended 8.07 mm past the neck when torqued, but the load cell interface plate was only 7.90 mm thick. All components were within the drawing specifications, but since there was no assembled specification, interference occurred.

For the final rule, this situation has been corrected by shortening the cable and adding a new, special-purpose retaining nut that provides the necessary clearance. Additionally, the TDP provides drawings for a wrench designed to accept the specialized nut, the use of which makes it easier to properly torque the nut on the center cable. (The PADI provides detailed assembly instructions on adjusting the nut.)

The neck cable assembly (part number 020-2415) of an older Q3s unit may be swapped out with a revised cable and new lock nut with no further changes to the dummy. NHTSA

performed neck qualification tests with the agency's older units fitted with the revised cable and nut and confirmed that it did not affect the performance of the neck. (The results are documented in "Q3s Engineering Drawing Changes, Rev. J, May 2016," *supra*.) Owners of older Q3s units may still use an older, unrevised cable assembly as long as there is clearance between the retaining nut and the surface of the neck end plate.

Mass and anthropometry. The main assembly drawing of the Q3s (drawing 020-0100) contains separate sheets that provide mass and anthropometry measurements and tolerances of various body segments. In the NPRM, these measurements were based on the four units owned by NHTSA and the recommendations of HIS. For the final rule, the sheets have been updated to reflect measurements and tolerances derived from the larger pool of dummies. All revisions are also closer to biofidelity targets. For example, the overall mass has been changed to 14.5 kg (from 14.233 kg), which matches the human target.

Other general changes: errors and missing dimensional information, fit and assembly, manufacturing preferences. These changes have been made to improve the production and manufacture of future Q3s dummies. An older Q3s dummy is not affected by these revisions.

Errors and missing dimensional information. Several drawings are changed to correct errors or add missing information. Examples include the use of a standard convention to specify hole locations and diameters and additional views (such as isometrics) to clearly show part dimensions and assemblies.

Fit and assembly. Several drawings have revised dimensions that make existing parts fit better and assemble more easily. Examples include slight changes on many dimensions, including overall dimensions, hole locations, and the addition of chamfers to parts.

Manufacturing preferences. Some drawings are revised to accommodate manufacturing material selections and material processes. An example is a change to the finish on the femur bone. Also, some revisions make the material call-outs on parts more general, to give dummy manufacturers more leeway on material selection in meeting the acceptance criteria for the qualification tests. Examples include call-outs for rubber, vinyl, or urethane parts.

Procedures for Assembly, Disassembly, and Inspection (PADI)

Neck assembly. Section 5.3, Neck, has been updated to reflect the installation of a protective cap over a revised lock nut for the neck center cable. (This change is discussed above.) Also, the version of the PADI in the NPRM depicted an outdated version of the neck center cable. Pictures and illustrations of this part have been updated in accordance with drawing 202-2415, *Tension cable assembly*, which shows a round fitting attached to the cable. Prior to the NPRM, an older version of the dummy had used a square fitting, and the agency mistakenly depicted the square fitting in the PADI.

Jam nuts for lumbar cable. Section 5.7.3, *Lower Torso Assembly and Installation*, has been updated to reflect installation of jam nuts in lieu of a lock nut with a nylon insert. This issue has been discussed in an earlier section.

New part numbers for several fasteners. For this final rule, several engineering drawings have been revised to reflect new part numbers for fasteners. Correspondingly, the agency has revised table listings throughout the PADI to reflect the new part numbers. In most cases, only the part number has changed, not the part itself, so corresponding changes to pictures and descriptions were not necessary. There were, however, a limited number of new parts, such as the new lock nut and snap cap on the neck center cable, that have been added to the PADI with new pictures.

X. Other Issues

a. Durability

Any dummy codified into 49 CFR Part 572 must have sufficient durability. In general, the energy levels in Part 572 qualification tests represent the energy levels at which dummies are expected to be exposed in the FMVSS applications.

As discussed in the NPRM (78 FR at 69961-69965), NHTSA assessed the durability of the Q3s dummy and did not see any durability problems. High-energy tests were run using the standard qualification test conditions at increased kinetic energy levels. Dummy positioning and set-up procedures were like that specified for the qualification procedures, but the impact speeds (and energy levels) were increased. This was achieved by dropping the test probe from a greater height. High energy tests were conducted for the head, neck, shoulder, thorax (with and without arm), lumbar, and pelvis. There were no problems with durability in any of the tests.

NHTSA did not find a need to repeat the high-level energy testing discussed in the NPRM since the data had demonstrated the Q3s's sufficient durability. The agency also notes that the four NHTSA-owned units have been in service since 2011, and the agency's records indicate that the torn lumbar column (described earlier) was the only instance of Q3s part failure of any sort.⁵⁵

Given the results of the durability testing discussed in the NPRM and the agency's record of low maintenance to its own Q3s units, the dummy is demonstrated to be highly durable and suitable for use in FMVSS No. 213.

⁵⁵ In NHTSA's experience with other Part 572 ATDs, deformable parts typically have the shortest service lives. The parts that are replaced most often are those that are either molded or bonded together (such as the Q3s lumbar assembly). For example, NHTSA has found the typical service life for HIII-10C rib sets and neck assemblies to be about thirty sled tests.

b. Consideration of Alternatives

As discussed in the NPRM, NHTSA considered alternative test dummies to incorporate into Part 572 instead of the Q3s, but none were better than the Q3s for testing CRSs in the proposed FMVSS No. 213 side impact test. The closest viable alternatives were the modified HIII-3C and the Q3.

The HIII-3C is a “frontal” test dummy used in FMVSS No. 208, “Occupant crash protection,” to evaluate air bag aggressiveness or air bag suppression when a child is close to a deploying air bag, and in FMVSS No. 213’s frontal sled test for the evaluation of child restraint performance. The HIII-3C was not designed for lateral impacts, but the agency developed a retrofit package for the dummy to install a new head and neck with better lateral biofidelity. The retrofitted dummy is referred to as the “3Cs.” As explained in the NPRM, the Q3s outperformed or is equivalent to the 3Cs in every aspect of biofidelity related to a dummy’s response in a side impact. In addition, the Q3s has thorax deflection instrumentation, which the 3Cs does not. NHTSA has concluded that the Q3s is a better dummy than the 3Cs to measure injury assessment values in side impacts and is a preferable ATD for use in the proposed side impact upgrade to FMVSS No. 213.

The Q3s was derived from the original Q3 dummy developed in Europe. The Q3 is intended for use in frontal, side, and rear impacts. Many of the Q3’s basic design concepts are included in the Q3s. However, as reported by the European Enhanced Vehicle-Safety Committee (Wismans, et al., 2008), the Q3s is superior to the Q3 in terms of lateral biofidelity and other matters. NHTSA considers the Q3s preferable to the Q3 for the proposed FMVSS No. 213 side impact test.

NHTSA concludes that the Q3s is superior to other commercially available child side impact test dummies and should be adopted into 49 CFR Part 572. The Q3s dummy is a state-of-the-art device that will allow for a better assessment of the risk of injury to child occupants than the 3Cs or the Q3. The availability of Q3s's injury measuring capability is important to the design, development and evaluation of the side impact protection provided by child restraint systems. The Q3s test dummy is available today, and has been thoroughly evaluated for suitable reproducibility and repeatability of results.

XI. Rulemaking Analyses and Notices

Executive Order 12866, Executive Order 13563, and DOT Rulemaking Procedures

We have considered the potential impact of this final rule under Executive Orders 12866 and 13563, and the Department of Transportation's administrative rulemaking procedures set forth in 49 CFR part 5, subpart B. This final rule has been determined to be nonsignificant and was not reviewed by the Office of Management and Budget (OMB) under E.O. 12866. We have considered the qualitative costs and benefits of this final rule under the principles of E.O. 12866.

This document would amend 49 CFR Part 572 by adding design and performance specifications for a test dummy representative of a 3-year-old child that the agency plans to use in FMVSS No. 213 side impact compliance tests and for research purposes. As stated in 49 CFR 572.3, *Application*, Part 572 does not in itself impose duties or liabilities on any person. It only serves to describe the test tools that measure the performance of occupant protection systems. Thus, this Part 572 rule itself does not impose any requirements on anyone. Businesses are affected only if they choose to manufacture or test with the dummy. Because the economic impacts of this rule are minimal, no further regulatory evaluation is necessary.

There are benefits associated with this rulemaking but they cannot be quantified. The incorporation of the Q3s into 49 CFR Part 572 would enable NHTSA to use the ATD in the proposed FMVSS No. 213 side impact test. Adoption of side impact protection requirements in FMVSS No. 213 enhances child passenger safety and fulfills a mandate in MAP-21 that NHTSA “issue a final rule amending Federal Motor Vehicle Safety Standard Number 213 to improve the protection of children seated in child restraint systems during side impact crashes.”⁵⁶ In addition, the availability of the Q3s in a standardized, regulated format would be beneficial by providing a suitable, stabilized, and objective test tool to the safety community for use in better protecting children in side impacts.

The costs associated with the Q3s only affect those who choose to use the Q3s. This Part 572 final rule does not impose any requirements on anyone. If incorporated into an FMVSS, NHTSA will use the Q3s in its compliance testing of the requirements, but regulated entities are not required to use the Q3s or assess the performance of their products in the manner specified in the FMVSSs.

Based on NHTSA’s dummy purchase contract with HIS, the estimated cost of an uninstrumented Q3s dummy is approximately \$50,000. Instruments installed within the dummy needed to perform the qualification in accordance with Part 572 include: three uni-axial accelerometers within the head of the dummy (about \$500 each); an upper neck load cell (about \$10,000); a shoulder potentiometer (about \$500); and a single-axis IR-TRACC within the thorax cavity (about \$8,000). The cost of this instrumentation adds approximately \$20,000 for a total cost of about \$70,000.

⁵⁶ Section 31501(a) of Subtitle E, “Child Safety Standards,” MAP-21, P.L. 112-141.

There are minor costs associated with conducting the qualification tests. Most of the qualification fixtures are common with those used to qualify other Part 572 dummies (including the neck pendulum, the quick-release fixture used in the head drop test, and the bench used in the probe impact tests). Some additional equipment unique to the Q3s may be fabricated from drawings within the technical data package, for an estimated cost of about \$20,000 (price may vary widely depending on prevailing labor rates). This includes the cost to fabricate a load cell blank⁵⁷ used in the head drop tests, the torsion fixture for the neck torsion test, the special headform used in the neck and lumbar flexion tests, the leg positioning tool used in the probe impact tests, and the 3.81 kg test probe itself. The costs of the instrumentation equipment needed to perform the qualification tests amounts to an additional \$3,460 (two angular rate sensors, \$1,230 apiece; one test probe accelerometer, \$500; one rotary potentiometer, \$500.) This Part 572 rule does not impose these costs on anyone. Child restraint manufacturers are affected by this final rule only if they elect to use the Q3s to test their products.

Dummy refurbishments and part replacements are a routine part of ATD testing. Various parts will likely have to be refurbished or replaced. However, the Q3s has proven to have high durability in sled testing. In addition, since the dummies are designed to be reusable, costs of the dummies and of parts can be amortized over a number of tests.

Executive Order 13771

Executive Order 13771 titled “Reducing Regulation and Controlling Regulatory Costs,” directs that, unless prohibited by law, whenever an executive department or agency publicly proposes for notice and comment or otherwise promulgates a new regulation, it shall identify at

⁵⁷ See drawing 020-0150 in the TDP.

least two existing regulations to be repealed. In addition, any new incremental costs associated with new regulations shall, to the extent permitted by law, be offset by the elimination of existing costs. Only those rules deemed significant under section 3(f) of Executive Order 12866, “Regulatory Planning and Review,” are subject to these requirements. As discussed above, this rule is not a significant rule under Executive Order 12866 and, accordingly, is not subject to the offset requirements of 13771.

Regulatory Flexibility Act

Pursuant to the Regulatory Flexibility Act (5 U.S.C. 601 et seq., as amended by the Small Business Regulatory Enforcement Fairness Act (SBREFA) of 1996), whenever an agency is required to publish a proposed or final rule, it must prepare and make available for public comment a regulatory flexibility analysis that describes the effect of the rule on small entities (i.e., small businesses, small organizations, and small governmental jurisdictions), unless the head of the agency certifies the rule will not have a significant economic impact on a substantial number of small entities. The Small Business Administration’s regulations at 13 CFR Part 121 define a small business, in part, as a business entity “which operates primarily within the United States.” (13 CFR 121.105(a)).

NHTSA has considered the effects of this rulemaking under the Regulatory Flexibility Act. I hereby certify that this rulemaking action will not have a significant economic impact on a substantial number of small entities. This action will not have a significant economic impact on a substantial number of small entities because the addition of the test dummy to Part 572 will not impose any requirements on anyone. NHTSA will use the ATD in agency testing but will not require anyone to manufacture the dummy or to test motor vehicles or motor vehicle equipment with it.

National Environmental Policy Act

NHTSA has analyzed this final rule for the purposes of the National Environmental Policy Act and determined that it will not have any significant impact on the quality of the human environment.

Executive Order 13045 and 13132 (Federalism)

Executive Order 13045 (62 FR 19885, April 23, 1997) applies to any rule that: (1) is determined to be “economically significant” as defined under E.O. 12866, and (2) concerns an environmental, health, or safety risk that NHTSA has reason to believe may have a disproportionate effect on children. If the regulatory action meets both criteria, NHTSA must evaluate the environmental health or safety effects of the planned rule on children, and explain why the planned regulation is preferable to other potentially effective and reasonably feasible alternatives considered by the agency.

This final rule is not subject to the Executive Order because it is not economically significant as defined in E.O. 12866.

NHTSA has examined today’s final rule pursuant to Executive Order 13132 (64 FR 43255, August 10, 1999) and concluded that no additional consultation with States, local governments or their representatives is mandated beyond the rulemaking process. The agency has concluded that this final rule will not have federalism implications because the rule would not have “substantial direct effects on the States, on the relationship between the national government and the States, or on the distribution of power and responsibilities among the various levels of government.” This final rule will not impose any requirements on anyone. Businesses will be affected only if they choose to manufacture or test with the dummy.

Further, no consultation is needed to discuss the preemptive effect of today's final rule. NHTSA's safety standards can have preemptive effect in two ways. This rule amends 49 CFR Part 572 and is not a safety standard.⁵⁸ This Part 572 final rule will not impose any requirements on anyone.

Civil Justice Reform

With respect to the review of the promulgation of a new regulation, section 3(b) of Executive Order 12988, "Civil Justice Reform" (61 FR 4729, February 7, 1996) requires that Executive agencies make every reasonable effort to ensure that the regulation: (1) Clearly specifies the preemptive effect; (2) clearly specifies the effect on existing Federal law or regulation; (3) provides a clear legal standard for affected conduct, while promoting simplification and burden reduction; (4) clearly specifies the retroactive effect, if any; (5) adequately defines key terms; and (6) addresses other important issues affecting clarity and general draftsmanship under any guidelines issued by the Attorney General. This document is consistent with that requirement.

Pursuant to this Order, NHTSA notes as follows.

The issue of preemption is discussed above in connection with E.O. 13132. NHTSA notes further that there is no requirement that individuals submit a petition for reconsideration or pursue other administrative proceeding before they may file suit in court.

Paperwork Reduction Act

⁵⁸ With respect to the safety standards, the National Traffic and Motor Vehicle Safety Act contains an express preemptive provision: "When a motor vehicle safety standard is in effect under this chapter, a State or a political subdivision of a State may prescribe or continue in effect a standard applicable to the same aspect of performance of a motor vehicle or motor vehicle equipment only if the standard is identical to the standard prescribed under this chapter." 49 U.S.C. 30103(b)(1). Second, the Supreme Court has recognized the possibility of implied preemption: State requirements imposed on motor vehicle manufacturers, including sanctions imposed by State tort law, can stand as an obstacle to the accomplishment and execution of a NHTSA safety standard. When such a conflict exists, the Supremacy Clause of the Constitution makes the State requirements unenforceable. See Geier v. American Honda Motor Co., 529 U.S. 861 (2000).

Under the Paperwork Reduction Act of 1995, a person is not required to respond to a collection of information by a Federal agency unless the collection displays a valid control number from the Office of Management and Budget (OMB). This final rule will not have any requirements that are considered to be information collection requirements as defined by the OMB in 5 CFR Part 1320.

National Technology Transfer and Advancement Act

Section 12(d) of the National Technology Transfer and Advancement Act of 1995 (NTTAA), Public Law 104-113, section 12(d) (15 U.S.C. 272) directs NHTSA to use voluntary consensus standards in its regulatory activities unless doing so would be inconsistent with applicable law or otherwise impractical. Voluntary consensus standards are technical standards (e.g., materials specifications, test methods, sampling procedures, and business practices) that are developed or adopted by voluntary consensus standards bodies. The NTTAA directs NHTSA to provide Congress, through OMB, explanations when the agency decides not to use available and applicable voluntary consensus standards.

The following voluntary consensus standards have been used in developing the Q3s:

- SAE Recommended Practice J211, Rev. Mar 95, “Instrumentation for Impact Tests – Part 1 – Electronic Instrumentation;” and
- SAE J1733 of 1994-12 “Sign Convention for Vehicle Crash Testing.”

Unfunded Mandates Reform Act

Section 202 of the Unfunded Mandates Reform Act of 1995 (UMRA), Pub. L. 104-4, requires Federal agencies to prepare a written assessment of the costs, benefits, and other effects of proposed or final rules that include a Federal mandate likely to result in the expenditure by State, local, or tribal governments, in the aggregate, or by the private sector, of more than \$100

million annually (adjusted for inflation with base year of 1995). Before promulgating a NHTSA rule for which a written statement is needed, section 205 of the UMRA generally requires the agency to identify and consider a reasonable number of regulatory alternatives and adopt the least costly, most cost-effective, or least burdensome alternative that achieves the objectives of the rule.

This final rule will not impose any unfunded mandates under the UMRA. This rule does not meet the definition of a Federal mandate because it does not impose requirements on anyone. It amends 49 CFR Part 572 by adding design and performance specifications for a 3-year-old child side impact test dummy that the agency would use in FMVSS No. 213 and for research purposes. This final rule would affect only those businesses that choose to manufacture or test with the dummy. It would not result in costs of \$100 million or more to either State, local, or tribal governments, in the aggregate, or to the private sector.

Incorporation by Reference

Under regulations issued by the Office of the Federal Register (1 CFR 51.5(a)), an agency, as part of a final rule that includes material incorporated by reference, must summarize in the preamble of the final rule the material it incorporates by reference and discuss the ways the material is reasonably available to interested parties or how the agency worked to make materials available to interested parties.

In this final rule, NHTSA incorporates by reference a technical data package for the Q3s consisting of a set of engineering drawings for the test dummy, a parts list, and a user's manual that has procedures for assembly, disassembly, and inspection of the dummy. Q3s dummies manufactured to meet the qualification requirements and the technical data package will be uniform in their design, construction, and response to impact forces.

NHTSA has placed a copy of the technical data package in the docket for this final rule. Interested persons can download a copy of the materials or view the materials online by accessing www.Regulations.gov, telephone 1-877-378-5457, or by contacting NHTSA's Chief Counsel's Office at the phone number and address set forth in the "For Further Information" section of this document. The material is also available for inspection at the Department of Transportation, Docket Operations, Room W12-140, 1200 New Jersey Avenue, S.E., Washington, D.C. Telephone: 202-366-9826. This final rule also incorporates versions of SAE Recommended Practice J211/1 parts 1 and 2 and SAE J1733. The material is available for review at NHTSA and is available for purchase from SAE International.

Plain Language

Executive Order 12866 requires each agency to write all rules in plain language. Application of the principles of plain language includes consideration of the following questions:

Has the agency organized the material to suit the public's needs?

Are the requirements in the rule clearly stated?

Does the rule contain technical language or jargon that is not clear?

Would a different format (grouping and order of sections, use of headings, paragraphing) make the rule easier to understand?

Would more (but shorter) sections be better?

Could the agency improve clarity by adding tables, lists, or diagrams?

What else could the agency do to make this rulemaking easier to understand?

If you have any responses to these questions, please send them to NHTSA.

Regulation Identifier Number

The Department of Transportation assigns a regulation identifier number (RIN) to each regulatory action listed in the Unified Agenda of Federal Regulations. The Regulatory Information Service Center publishes the Unified Agenda in April and October of each year. You may use the RIN contained in the heading at the beginning of this document to find this action in the Unified Agenda.

List of Subjects in 49 CFR Part 572

Motor vehicle safety, Incorporation by reference.

In consideration of the foregoing, NHTSA amends 49 CFR Part 572 as follows:

PART 572-ANTHROPOMORPHIC TEST DEVICES

1. The authority citation for Part 572 continues to read as follows:

Authority: 49 U.S.C. 322, 30111, 30115, 30117 and 30166; delegation of authority at 49 CFR 1.95.

2. 49 CFR Part 572 is amended by adding a new Subpart W consisting of §§ 572.210 through 572.219 to read as follows:

Subpart W – Q3s Three-Year-Old Child Test Dummy

Secs.

572.210 Incorporation by reference.

572.211 General description.

572.212 Head assembly and test procedure.

572.213 Neck assembly and test procedure.

572.214 Shoulder assembly and test procedure.

572.215 Thorax with arm assembly and test procedure.

572.216 Thorax without arm assembly and test procedure.

572.217 Lumbar spine assembly and test procedure.

572.218 Pelvis assembly and test procedure.

572.219 Test conditions and instrumentation.

Appendix – Figures to Subpart W of Part 572

§ 572.210 Incorporation by reference

Certain material is incorporated by reference (IBR) into this part with the approval of the Director of the Federal Register under 5 U.S.C. 552(a) and 1 CFR part 51. To enforce any edition other than that specified in this section, NHTSA must publish a document in the *Federal Register* and the material must be available to the public. All approved material is available for inspection at the Department of Transportation, Docket Operations, Room W12-140, 1200 New Jersey Avenue, SE, Washington DC 20590, telephone 202-366-9826, and is available from the sources listed in the following paragraphs in this section. It is also available for inspection at the National Archives and Records Administration (NARA). For information on the availability of this material at NARA, email fedreg.legal@nara.gov or go to www.archives.gov/federal-register/cfr/ibr-locations.html.

(a) NHTSA Technical Information Services, 1200 New Jersey Ave., S.E., Washington, D.C. 20590, telephone 202-366-5965.

(1) A parts/drawing list entitled, “Parts/Drawings List, Part 572 Subpart W, Q3s Three-Year-Old Child Side Impact Dummy, May 2016,” (Parts/Drawings List); IBR approved for §572.211.

(2) A drawings and inspection package entitled, “Drawings and Specifications for Q3S Three-Year-Old Child Test Dummy, Part 572 Subpart W, May 2016,” (Drawings and

Specifications); IBR approved for §§572.211, 572.212, 572.213, 572.214, 572.215, 572.216, 572.217, 572.218, and 572.219.

(3) A procedures manual entitled “Procedures for Assembly, Disassembly, and Inspection (PADI) of the Q3s Child Side Impact Crash Test Dummy, May 2016,” (PADI); IBR approved for §§572.211, 572.215(b)(1), 572.216(b)(1), and 572.219(a)(1).

(b) SAE International, 400 Commonwealth Drive, Warrendale, PA 15096, call 1-877-606-7323, <https://www.sae.org/>.

(1) SAE Recommended Practice J211/1, Rev. Mar 95, “Instrumentation for Impact Tests – Part 1 – Electronic Instrumentation,” (SAE J211); IBR approved for §572.219;

(2) SAE Information Report J1733 of 1994-12, “Sign Convention for Vehicle Crash Testing,” December 1994, (SAE J1733); IBR approved for §572.219.

§ 572.211 General description

(a) The Q3s Three-Year-Old Child Test Dummy is defined by the following materials:

- (1) The Parts/Drawings List (incorporated by reference, see §572.210);
- (2) The Drawings and Specifications (incorporated by reference, see §572.210);
- (3) The PADI (incorporated by reference, see §572.210).

(b) The structural properties of the dummy are such that the dummy conforms to this subpart in every respect before use in any test.

§ 572.212 Head assembly and test procedure

All assemblies and drawings referenced in this section are contained in Drawings and Specifications, incorporated by reference, see §572.210.

(a) The head assembly for this test consists of the complete head (drawing 020-1200) with head accelerometer assembly (drawing 020-1013A), and a half mass simulated upper neck load cell (drawing 020-1050).

(b) When the head assembly is tested according to the test procedure in paragraph (c) of this section, it shall have the following characteristics:

(1) *Frontal head qualification test.* When the head assembly is dropped from a height of 376.0 ± 1.0 mm in accordance with subsection (c) of this section, the peak resultant acceleration at the location of the accelerometers at the head CG shall have a value between 255 G and 300 G. The resultant acceleration vs. time history curve shall be unimodal; oscillations occurring after the main pulse must be less than 10 percent of the peak resultant acceleration. The lateral acceleration shall not exceed 15 G (zero to peak).

(2) *Lateral head qualification test.* When the head assembly is dropped from a height of 200.0 ± 1.0 mm in accordance with subsection (c) of this section, the peak resultant acceleration at the location of the accelerometers at the head CG shall have a value between 114 G and 140 G. The resultant acceleration vs. time history curve shall be unimodal; oscillations occurring after the main pulse must be less than 10 percent of the peak resultant acceleration. The X-component acceleration shall not exceed 15 G (zero to peak).

(c) The test procedure for the head assembly is as follows:

(1) Soak the head assembly in a controlled environment at any temperature between 20.6 and 22.2 °C and a relative humidity from 10 to 70 percent for at least four hours prior to a test.

(2) Prior to the test, clean the impact surface of the skin and the impact plate surface with isopropyl alcohol, trichloroethane, or an equivalent. The skin of the head and the impact plate surface must be clean and dry for testing.

(3)(i) For the frontal head test, suspend and orient the head assembly with the forehead facing the impact surface as shown in Figure W1 in appendix A to this subpart. The lowest point on the forehead must be 376.0 ± 1.0 mm from the impact surface. Assure that the head is horizontal laterally. Adjust the head angle so that the upper neck load cell simulator is 28 ± 2 degrees forward from the vertical while assuring that the head remains horizontal laterally.

(ii) For the lateral head test, the head is dropped on the aspect that opposes the primary load vector of the ensuing full scale test for which the dummy is being qualified. A left drop set up that is used to qualify the dummy for an ensuing full scale left side impact is depicted in Figure W2 in appendix A to this subpart. A right drop set-up would be the mirror image of that shown in Figure W2. Suspend and orient the head assembly as shown in Figure W2. The lowest point on the impact side of the head must be 200.0 ± 1.0 mm from the impact surface. Assure that the head is horizontal in the fore-aft direction. Adjust the head angle so that the head base plane measured from the base surface of the upper neck load cell simulator is 35 ± 2 degrees forward from the vertical while assuring that the head remains horizontal in the fore-aft direction.

(4) Drop the head assembly from the specified height by means that ensure a smooth, instant release onto a rigidly supported flat horizontal steel plate which is 50.8 mm thick and 610 mm square. The impact surface shall be clean, dry and have a surface finish of not less than 0.2 microns (RMS) and not more than 2.0 microns (RMS).

(5) Allow at least 2 hours between successive tests on the same head.

§572.213 Neck assembly and test procedure

All assemblies and drawings referenced in this section are contained in Drawings and Specifications, incorporated by reference, see §572.210.

(a)(1) The neck and headform assembly for the purposes of the fore-aft neck flexion and lateral neck flexion qualification tests, as shown in Figures W3 and W4 in appendix A to this subpart, consists of the headform (drawing 020-9050, sheet 1) with angular rate sensor installed (drawing SA572-S58), six-channel neck/lumbar load cell (drawing SA572-S8), neck assembly (drawing 020-2400), neck/torso interface plate (drawing 020-9056) and pendulum interface plate (drawing 020-9051) with angular rate sensor installed (drawing SA572-S58).

(2) The neck assembly for the purposes of the neck torsion qualification test, as shown in Figure W5 in appendix A to this subpart, consists of the neck twist fixture (drawing DL210-200) with rotary potentiometer installed (drawing SA572-S51), neck adaptor plate assembly (drawing DL210-220), neck assembly (drawing 020-2400), six-channel neck/lumbar load cell (drawing SA572-S8), and twist fixture end plate (drawing DL210-210) .

(b) When the neck and headform assembly as defined in paragraph (a)(1) of this section, or the neck assembly as defined in paragraph (a)(2) of this section, is tested according to the test procedure in paragraph (c) of this section, it shall have the following characteristics:

(1) *Fore-aft neck flexion qualification test.* (i) Plane D, referenced in Figure W3 in appendix A to this subpart, shall rotate in the direction of pre-impact flight with respect to the pendulum's longitudinal centerline between 69.5 degrees and 81.0 degrees. During the time interval while the rotation is within these angles, the peak moment measured by the neck transducer (drawing SA572-S8) shall have a value between 41.5 N-m and 50.7 N-m.

(ii) The decaying headform rotation vs. time curve shall cross the zero angle with respect to its initial position at time of impact relative to the pendulum centerline between 45 to 55 ms after the time the peak rotation value is reached.

(iii) All instrumentation data channels are defined to be zero when the longitudinal centerline of the neck and pendulum are parallel.

(iv) The headform rotation shall be calculated by the following formula with the integration beginning at time zero:

$$\text{Headform rotation (deg)} = \int [(\text{Headform Angular Rate})_y - (\text{Pendulum Angular Rate})_y] dt$$

(v) $(\text{Headform Angular Rate})_y$ is the angular rate about the y-axis in deg/sec measured on the headform (drawing 020-9050, sheet 1), and $(\text{Pendulum Angular Rate})_y$ is the angular rate about the y-axis in deg/sec measured on the pendulum interface plate (drawing 020-9051).

(2) *Lateral neck flexion qualification test.* (i) Plane D, referenced in Figure W4 in appendix A to this subpart, shall rotate in the direction of pre-impact flight with respect to the pendulum's longitudinal centerline between 76.5 degrees and 87.5 degrees. During the time interval while the rotation is within these angles, the peak moment measured by the neck transducer (drawing SA572-S8) shall have a value between 25.3 N-m and 32.0 N-m.

(ii) The decaying headform rotation vs. time curve shall cross the zero angle with respect to its initial position at time of impact relative to the pendulum centerline between 61 to 71 ms after the time the peak rotation value is reached.

(iii) All instrumentation data channels are defined to be zero when the longitudinal centerline of the neck and pendulum are parallel.

(iv) The headform rotation shall be calculated by the following formula with the integration beginning at time zero:

$$\text{Headform rotation (deg)} = \int [(\text{Headform Angular Rate})_y - (\text{Pendulum Angular Rate})_y] dt$$

(v) (Headform Angular Rate)_y is the angular rate about the y-axis in deg/sec measured on the headform (drawing 020-9050, sheet 1), and (Pendulum Angular Rate)_y is the angular rate about the y-axis in deg/sec measured on the pendulum interface plate (drawing 020-9051).

(3) *Neck torsion qualification test.* (i) The neck twist fixture (drawing DL210-200), referenced in Figure W5 in appendix A to this subpart, shall rotate in the direction of pre-impact flight with respect to the pendulum's longitudinal centerline between 74.5 degrees and 91.0 degrees, as measured by the rotary potentiometer (drawing SA572-S51). During the time interval while the rotation is within these angles, the peak moment measured by the neck transducer (drawing SA572-S8) shall have a value between 8.0 N-m and 10.0 N-m.

(ii) The decaying neck twist fixture rotation vs. time curve shall cross the zero angle with respect to its initial position at time of impact relative to the pendulum centerline between 85 to 102 ms after the time the peak rotation value is reached.

(iii) All instrumentation data channels are defined to be zero when the zero pins are installed such that the neck is not in torsion.

(c) The test procedure for the neck assembly is as follows:

(1) Soak the neck assembly in a controlled environment at any temperature between 20.6 and 22.2 °C and a relative humidity between 10 and 70 percent for at least four hours prior to a test.

(2)(i) For the fore-aft neck flexion test, mount the neck and headform assembly, defined in subsection (a)(1) of this section, on the pendulum, described in Figure 22 to §572.33, so that the midsagittal plane of the headform is vertical and coincides with the plane of motion of the pendulum, and with the neck placement such that the front side of the neck is closest to the honeycomb material as shown in Figure W3 in appendix A to this subpart.

(ii) For the lateral neck flexion test, the test is carried out in the direction opposing the primary load vector of the ensuing full scale test for which the dummy is being qualified. A right flexion test set-up that is used to qualify the dummy for an ensuing full scale right side impact is depicted in Figure W4 in appendix A to this subpart. A left flexion test set-up would be depicted by a mirror image of all components beneath the pendulum interface plate in Figure W4. Mount the neck and headform assembly, defined in paragraph (a)(1) of this section, on the pendulum, described by Figure 22 to §572.33, so that the midsagittal plane of the headform is vertical and coincides with the plane of motion of the pendulum, and with the neck placement such that the right (or left) side of the neck is closest to the honeycomb material as shown in Figure W4.

(iii) For the neck torsion test, the test is carried out in the direction opposing the primary load vector of the ensuing full scale test for which the dummy is being qualified. A right torsion test set-up that is used to qualify the dummy for an ensuing full scale right side impact is depicted in Figure W5 in appendix A to this subpart. A left flexion test set-up would be a mirror image of that shown in Figure W5. Mount the neck assembly, defined in paragraph (a)(2) of this section, on the pendulum, described by Figure 22 to §572.33, as shown in Figure W5 .

(3)(i) Release the pendulum and allow it to fall freely from a height to achieve an impact velocity of 4.7 ± 0.1 m/s for fore-aft flexion, 3.8 ± 0.1 m/s for lateral flexion, and 3.6 ± 0.1 m/s for torsion, measured by an accelerometer mounted on the pendulum at time zero.

(ii) Stop the pendulum from the initial velocity with an acceleration vs. time pulse that meets the velocity change as specified in Table 1 to this section. Integrate the pendulum accelerometer data channel to obtain the velocity vs. time curve beginning at time zero.

(iii) Time zero is defined as the time of initial contact between the pendulum striker plate and the honeycomb material.

TABLE 1 to §572.213

Time (ms)	Fore-aft Flexion (m/s)	Time (ms)	Lateral Flexion (m/s)	Time (ms)	Torsion (m/s)
10	1.1 – 2.1	10	1.7 – 2.2	10	0.9 – 1.3
20	2.8 – 3.8	15	2.5 – 3.0	15	1.4 – 2.0
30	4.1 – 5.1	20	3.4 – 3.9	20	2.0 – 2.6

§572.214 Shoulder assembly and test procedure

All assemblies and drawings referenced in this section are contained in Drawings and Specifications, incorporated by reference, see §572.210.

(a) The shoulder assembly for this test consists of the torso assembly (drawing 020-4500) with string pot assembly (drawing SA572-S38 or SA572-S39) installed.

(b) When the center of the shoulder of a completely assembled dummy (drawing 020-0100) is impacted laterally by a test probe conforming to §572.219, at 3.6 ± 0.1 m/s according to the test procedure in paragraph (c) of this section:

(1) Maximum lateral shoulder displacement (compression) relative to the spine, measured with the string potentiometer assembly (drawing SA572-S38 or SA572-S39), must not be less than 17.0 mm and not more than 22.0 mm. The peak force, measured by the impact probe as defined in §572.219 and calculated in accordance with paragraph (b)(2) of this section, shall have a value between 1123 N and 1437 N.

(2) The force shall be calculated by the product of the impactor mass and its measured deceleration.

(c) The test procedure for the shoulder assembly is as follows:

(1) The dummy is clothed in the Q3s suit (drawing 020-8001). No additional clothing or shoes are placed on the dummy.

(2) Soak the dummy in a controlled environment at any temperature between 20.6 and 22.2 °C and a relative humidity from 10 to 70 percent for at least four hours prior to a test.

(3) The shoulder test is carried out in the direction opposing the primary load vector of the ensuing full scale test for which the dummy is being qualified. A left shoulder test set-up that is used to qualify the dummy for an ensuing full scale left side impact is depicted in Figure W6 in appendix A to this subpart. A right shoulder set-up would be a mirror image of that shown in Figure W6. Seat the dummy on the qualification bench described in Figure V3 to § 572.194, the seat pan and seat back surfaces of which are covered with thin sheets of PTFE (Teflon) (nominal stock thickness: 2 to 3 mm) along the impact side of the bench.

(4) Position the dummy on the bench as shown in Figure W6, with the ribs making contact with the seat back oriented 24.6 degrees relative to vertical, the legs extended forward along the seat pan oriented 21.6 degrees relative to horizontal with the knees spaced 40 mm apart. Position the arms so that the upper arms are parallel to the seat back (± 2 degrees) and the lower arms are parallel to the dummy's sagittal plane and perpendicular to the upper arms. Move the elbows inward (medially) until initial contact occurs between the sleeve and the portion of the suit covering the thorax while maintaining the relationships between the arms, seat back, and sagittal plane.

(5) The target point of the impact is a point on the shoulder that is 15 mm above and perpendicular to the midpoint of a line connecting the centers of the bolt heads of the two lower bolts (part #5000010) that connect the upper arm assembly (020-9750) to the shoulder ball retaining ring (020-3533).

(6) Impact the shoulder with the test probe so that at the moment of contact the probe's longitudinal centerline should be horizontal (± 1 degree), and the centerline of the probe should be within 2 mm of the target point.

(7) Guide the test probe during impact so that there is no significant lateral, vertical, or rotational movement.

(8) No suspension hardware, suspension cables, or any other attachments to the probe, including the velocity vane, shall make contact with the dummy during the test.

§572.215 Thorax with arm assembly and test procedure

All assemblies and drawings referenced in this section are contained in Drawings and Specifications, incorporated by reference, see §572.210.

(a) The thorax assembly for this test consists of the torso assembly (drawing 020-4500) with an IR-TRACC (drawing SA572-S37) installed.

(b) When the thorax of a completely assembled dummy (drawing 020-0100) is impacted laterally by a test probe conforming to §572.219 at 5.0 ± 0.1 m/s according to the test procedure in paragraph (c) of this section:

(1) Maximum lateral thorax displacement (compression) relative to the spine, measured with the IR-TRACC (drawing SA572-S37) and processed as set out in the PADI (incorporated by reference, see §572.210), shall have a value between 22.5 mm and 27.5 mm. The peak force occurring after 5 ms, measured by the impact probe as defined in §572.219 and calculated in accordance with paragraph (b)(2) of this section, shall have a value between 1360 N and 1695 N.

(2) The force shall be calculated by the product of the impactor mass and its measured deceleration.

(3) Time zero is defined as the time of contact between the impact probe and the arm.

All channels should be at a zero level at this point.

(c) The test procedure for the thorax with arm assembly is as follows:

(1) The dummy is clothed in the Q3s suit (drawing 020-8001). No additional clothing or shoes are placed on the dummy.

(2) Soak the dummy in a controlled environment at any temperature between 20.6 and 22.2 °C and a relative humidity from 10 to 70 percent for at least four hours prior to a test.

(3) The test is carried out in the direction opposing the primary load vector of the ensuing full scale test for which the dummy is being qualified. A left thorax test set-up that is used to qualify the dummy for an ensuing full scale left side impact is depicted in Figure W7 in appendix A to this subpart. A right thorax set-up would be a mirror image of that shown in Figure W7. Seat the dummy on the qualification bench described in Figure V3 to §572.194, the seat pan and seat back surfaces of which are covered with thin sheets of PTFE (Teflon) (nominal stock thickness: 2 to 3 mm) along the impact side of the bench.

(4) Position the dummy on the bench as shown in Figure W7 in appendix A to this subpart, with the ribs making contact with the seat back oriented 24.6 degrees relative to vertical, the legs extended forward along the seat pan oriented 21.6 degrees relative to horizontal with the knees spaced 40 mm apart. On the non-impact side of the dummy, the long axis of the upper arm is positioned parallel to the seat back (± 2 degrees). On the impact side, the upper arm is positioned such that the target point intersects its long axis as described in paragraph (c)(5) of this section. The long axis of the upper arm is defined by section line A-A in drawing 020-9750. Both of the lower arms are set perpendicular to the upper arms and parallel to the dummy's sagittal plane. Move the elbows inward (medially) until initial contact occurs between the sleeve

and the portion of the suit covering the thorax while maintaining the relationships between the arms, seat back, and sagittal plane.

(5) The target point of the impact is the point of intersection on the lateral aspect of the upper arm and a line projecting from the thorax of the dummy. The projecting line is horizontal, runs parallel to the coronal plane of the dummy, and passes through the midpoint of a line connecting the centers of the bolt heads of the two IR-TRACC bolts (part #5000646). The projected line should intersect the upper arm within 2 mm of its long axis.

(6) Impact the arm with the test probe so that at the moment of contact the probe's longitudinal centerline should be horizontal (± 1 degrees), and the centerline of the probe should be within 2 mm of the target point.

(7) Guide the test probe during impact so that there is no significant lateral, vertical, or rotational movement.

(8) No suspension hardware, suspension cables, or any other attachments to the probe, including the velocity vane, shall make contact with the dummy during the test.

§572.216 Thorax without arm assembly and test procedure

All assemblies and drawings referenced in this section are contained in Drawings and Specifications, incorporated by reference, see §572.210.

(a) The thorax assembly for this test consists of the torso assembly (drawing 020-4500) with IR-TRACC (drawing SA572-S37) installed.

(b) When the thorax of a completely assembled dummy (drawing 020-0100) with the arm (drawing 020-9700 or 020-9800) on the impacted side removed is impacted laterally by a test probe conforming to §572.219 at 3.3 ± 0.1 m/s according to the test procedure in paragraph (c) of this section:

(1) Maximum lateral thorax displacement (compression) relative to the spine, measured with the IR-TRACC (drawing SA572-S37) and processed as set out in the PADI (incorporated by reference, see §572.210), shall have a value between 24.5 mm and 30.5 mm. The peak force, measured by the impact probe as defined in §572.219 and calculated in accordance with paragraph (b)(2) of this section, shall have a value between 610 N and 754 N.

(2) The force shall be calculated by the product of the impactor mass and its measured deceleration.

(c) The test procedure for the thorax without arm assembly is as follows:

(1) The dummy is clothed in the Q3s suit (drawing 020-8001). No additional clothing or shoes are placed on the dummy.

(2) Soak the dummy in a controlled environment at any temperature between 20.6 and 22.2 °C and a relative humidity from 10 to 70 percent for at least four hours prior to a test.

(3) The test is carried out in the direction opposing the primary load vector of the ensuing full scale test for which the dummy is being qualified. A left thorax test set-up that is used to qualify the dummy for an ensuing full scale left side impact is depicted in Figure W8 in appendix A to this subpart. A right thorax set-up would be a mirror image of that shown in Figure W8. Seat the dummy on the qualification bench described in Figure V3 to § 572.194, the seat pan and seat back surfaces of which are covered with thin sheets of PTFE (Teflon) (nominal stock thickness: 2 to 3 mm) along the impact side of the bench.

(4) Position the dummy on the bench as shown in Figure W8 in appendix A to this subpart, with the ribs making contact with the seat back oriented 24.6 degrees relative to vertical, the legs extended forward along the seat pan oriented 21.6 degrees relative to horizontal with the

knees spaced 40 mm apart, and the arm on the non-impacted side positioned so that the upper arm is parallel (± 2 degrees) to the seat back and the lower arm perpendicular to the upper arm.

(5) The target point of the impact is the midpoint of a line between the centers of the bolt heads of the two IR-TRACC bolts (part #5000646).

(6) Impact the thorax with the test probe so that at the moment of contact the probe's longitudinal centerline should be horizontal (± 1 degrees), and the centerline of the probe should be within 2 mm of the target point.

(7) Guide the test probe during impact so that there is no significant lateral, vertical, or rotational movement.

(8) No suspension hardware, suspension cables, or any other attachments to the probe, including the velocity vane, shall make contact with the dummy during the test.

§572.217 Lumbar spine assembly and test procedure

All assemblies and drawings referenced in this section are contained in Drawings and Specifications, incorporated by reference, see §572.210.

(a) The lumbar spine and headform assembly for the purposes of the fore-aft lumbar flexion and lateral lumbar flexion qualification tests, as shown in Figures W9 and W10 in appendix A to this subpart, consists of the headform (drawing 020-9050, sheet 2) with angular rate sensor installed (drawing SA572-S58), six-channel neck/lumbar load cell (drawing SA572-S8), lumbar spine assembly (drawing 020-6000), lumbar interface plate (drawing 020-9062) and pendulum interface plate (drawing 020-9051) with angular rate sensor installed (drawing SA572-S58).

(b) When the lumbar spine and headform assembly is tested according to the test procedure in paragraph (c) of this section, it shall have the following characteristics:

(1) *Fore-aft lumbar flexion qualification test.* (i) Plane D, referenced in Figure W9 in appendix A to this subpart, shall rotate in the direction of pre-impact flight with respect to the pendulum's longitudinal centerline between 47.0 degrees and 58.5 degrees. During the time interval while the rotation is within these angles, the peak moment measured by the neck/lumbar transducer (drawing SA572-S8) shall have a value between 78.2 N-m and 96.2 N-m.

(ii) The decaying headform rotation vs. time curve shall cross the zero angle with respect to its initial position at time of impact relative to the pendulum centerline between 49 to 59 ms after the time the peak rotation value is reached.

(iii) All instrumentation data channels are defined to be zero when the longitudinal centerline of the lumbar spine and pendulum are parallel.

(iv) The headform rotation shall be calculated by the following formula with the integration beginning at time zero:

$$\text{Headform rotation (deg)} = \int [(\text{Headform Angular Rate})_y - (\text{Pendulum Angular Rate})_y] dt$$

(v) $(\text{Headform Angular Rate})_y$ is the angular rate about the y-axis in deg/sec measured on the headform (drawing 020-9050, sheet 2), and $(\text{Pendulum Angular Rate})_y$ is the angular rate about the y-axis in deg/sec measured on the pendulum interface plate (drawing 020-9051).

(2) *Lateral lumbar flexion qualification test.* (i) Plane D, referenced in Figure W10, shall rotate in the direction of pre-impact flight with respect to the pendulum's longitudinal centerline between 46.1 degrees and 58.2 degrees. During the time interval while the rotation is within these angles, the peak moment measured by the neck/lumbar transducer (drawing SA572-S8) shall have a value between 79.4 N-m and 98.1 N-m.

(ii) The decaying headform rotation vs. time curve shall cross the zero angle with respect to its initial position at time of impact relative to the pendulum centerline between 48 to 59 ms after the time the peak rotation value is reached.

(iii) All instrumentation data channels are defined to be zero when the longitudinal centerline of the lumbar spine and pendulum are parallel.

(iv) The headform rotation shall be calculated by the following formula with the integration beginning at time zero:

$$\text{Headform rotation (deg)} = \int [(\text{Headform Angular Rate})_y - (\text{Pendulum Angular Rate})_y] dt$$

(v) $(\text{Headform Angular Rate})_y$ is the angular rate about the y-axis in deg/sec measured on the headform (drawing 020-9050, sheet 2), and $(\text{Pendulum Angular Rate})_y$ is the angular rate about the y-axis in deg/sec measured on the pendulum interface plate (drawing 020-9051).

(c) The test procedure for the lumbar spine assembly is as follows:

(1) Soak the lumbar spine assembly in a controlled environment at any temperature between 20.6 and 22.2 °C and a relative humidity between 10 and 70 percent for at least four hours prior to a test.

(2)(i) For the fore-aft lumbar flexion test, mount the lumbar spine and headform assembly, defined in subsection (a) of this section, on the pendulum described Figure 22 to §572.33 so that the midsagittal plane of the headform is vertical and coincides with the plane of motion of the pendulum, and with the lumbar spine placement such that the front side of the lumbar spine is closest to the honeycomb material.

(ii) For the lateral lumbar flexion test, the test is carried out in the direction opposing the primary load vector of the ensuing full scale test for which the dummy is being qualified. A right flexion test set-up that is used to qualify the dummy for an ensuing a full scale right side

impact is depicted in Figure W10 in appendix A to this subpart. A left flexion test set-up would be depicted by a mirror image of all components beneath the pendulum interface plate in Figure W10. Mount the lumbar spine and headform assembly, defined in paragraph (a)(1) of this section, on the pendulum described in Figure 22 to §572.33 so that the midsagittal plane of the headform is vertical and perpendicular to the direction of motion of the pendulum, and with the lumbar spine placement such that the right (or left) side of the lumbar spine is closest to the honeycomb material.

(3)(i) Release the pendulum and allow it to fall freely from a height to achieve an impact velocity of 4.4 ± 0.1 m/s, measured by an accelerometer mounted on the pendulum as shown in Figure 22 to §572.33 at time zero.

(ii) Stop the pendulum from the initial velocity with an acceleration vs. time pulse that meets the velocity change as specified in Table 1 to this section. Integrate the pendulum accelerometer data channel to obtain the velocity vs. time curve beginning at time zero.

(iii) Time zero is defined as the time of initial contact between the pendulum striker plate and the honeycomb material.

TABLE 1 to §572.217

Time (ms)	Fore-aft Flexion (m/s)	Lateral Flexion (m/s)
10	1.3 – 1.7	1.3 – 1.7
20	2.7 – 3.7	2.7 – 3.7
30	4.1 – 4.9	4.0 – 4.8

§572.218 Pelvis assembly and test procedure

All assemblies and drawings referenced in this section are contained in Drawings and Specifications, incorporated by reference, see §572.210.

(a) The pelvis assembly (drawing 020-7500) for this test may include either a uniaxial pubic load cell (drawing SA572-S7) or a pubic load cell structural replacement (drawing 020-7150) installed on the non-impact side of the pelvis.

(b) When the center of the pelvis of a completely assembled dummy (drawing 020-0100) is impacted laterally by a test probe conforming to §572.219 at 4.0 ± 0.1 m/s according to the test procedure in paragraph (c) of this section:

(1) The peak force, measured by the impact probe as defined in §572.219 and calculated in accordance with paragraph (b)(2) of this section, shall have a value between 1587 N and 1901 N.

(2) The force shall be calculated by the product of the impactor mass and its measured deceleration.

(c) The test procedure for the pelvis assembly is as follows:

(1) The dummy is clothed in the Q3s suit (drawing 020-8001). No additional clothing or shoes are placed on the dummy.

(2) Soak the dummy in a controlled environment at any temperature between 20.6 and 22.2 °C (69 and 72 °F) and a relative humidity from 10 to 70 percent for at least four hours prior to a test.

(3) The pelvis test is carried out in the direction opposing the primary load vector of the ensuing full scale test for which the dummy is being qualified. A left pelvis test set-up that is used to qualify the dummy for an ensuing full scale left side impact is depicted in Figure W11 in appendix A to this subpart. A right pelvis test set-up would be a mirror image of that shown in Figure W11. Seat the dummy on the qualification bench described in Figure V3 to § 572.194,

the seat pan and seat back surfaces of which are covered with thin sheets of PTFE (Teflon) (nominal stock thickness: 2 to 3 mm) along the impact side of the bench.

(4) Position the dummy on the bench as shown in Figure W11 in appendix A to this subpart, with the ribs making contact with the seat back oriented 24.6 degrees relative to vertical, the legs extended forward along the seat pan oriented 21.6 degrees relative to horizontal with the knees spaced 40 mm apart. The arms should be positioned so that the arm on the non-impacted side is parallel to the seat back with the lower arm perpendicular to the upper arm, and the arm on the impacted side is positioned upwards away from the pelvis.

(5) Establish the impact point at the center of the pelvis so that the impact point of the longitudinal centerline of the probe is located 185 mm from the center of the knee pivot screw (part #020-9008) and centered vertically on the femur.

(6) Impact the pelvis with the test probe so that at the moment of contact the probe's longitudinal centerline should be horizontal (± 1 degrees), and the centerline of the probe should be within 2 mm of the center of the pelvis.

(7) Guide the test probe during impact so that there is no significant lateral, vertical, or rotational movement.

(8) No suspension hardware, suspension cables, or any other attachments to the probe, including the velocity vane, shall make contact with the dummy during the test.

§572.219 Test conditions and instrumentation

All assemblies and drawings referenced in this section are contained in Drawings and Specifications, incorporated by reference, see §572.210.

(a) The following test equipment and instrumentation is needed for qualification as set forth in this subpart:

(1) The test probe for shoulder, thorax, and pelvis impacts is of rigid metallic construction, concentric in shape, and symmetric about its longitudinal axis. It has a mass of 3.81 ± 0.02 kg and a minimum mass moment of inertia of 560 kg-cm^2 in yaw and pitch about the CG. One-third ($1/3$) of the weight of the suspension cables and their attachments to the impact probe is included in the calculation of mass, and such components may not exceed five percent of the total weight of the test probe. The impacting end of the probe, perpendicular to and concentric with the longitudinal axis, is at least 25.4 mm long, and has a flat, continuous, and non-deformable 70.0 ± 0.25 mm diameter face with an edge radius between 6.4 – 12.7 mm. The probe's end opposite to the impact face has provisions for mounting of an accelerometer with its sensitive axis collinear with the longitudinal axis of the probe. No concentric portions of the impact probe may exceed the diameter of the impact face. The impact probe shall have a free air resonant frequency of not less than 1000 Hz, which may be determined using the procedure listed in the PADI (incorporated by reference, see §572.210).

(2) Head accelerometers have dimensions, response characteristics, and sensitive mass locations specified in drawing SA572-S4 and are mounted in the head as shown in drawing 020-0100, sheet 2 of 5.

(3) The upper neck force and moment transducer has the dimensions, response characteristics, and sensitive axis locations specified in drawing SA572-S8 and is mounted in the head-neck assembly as shown in drawing 020-0100, sheet 2 of 5.

(4) The angular rate sensors for the fore-aft neck flexion and lateral neck flexion qualification tests have the dimensions and response characteristics specified in drawing SA572-S58 and are mounted in the headform and on the pendulum as shown in Figures W3 and W4 in appendix A to this subpart.

(5) The string potentiometer shoulder deflection transducers have the dimensions and response characteristics specified in drawing SA572-S38 or SA572-S39 and are mounted to the torso assembly as shown in drawing 020-0100, sheet 2 of 5.

(6) The IR-TRACC thorax deflection transducers have the dimensions and response characteristics specified in drawing SA572-S37 and are mounted to the torso assembly as shown in drawing 020-0100, sheet 2 of 5.

(7) The lumbar spine force and moment transducer has the dimensions, response characteristics, and sensitive axis locations specified in drawing SA572-S8 and is mounted in the torso assembly as shown in drawing 020-0100, sheet 2 of 5.

(8) The angular rate sensors for the fore-aft lumbar flexion and lateral lumbar flexion qualification tests have the dimensions and response characteristics specified in drawing SA572-S58 and are mounted in the headform and on the pendulum as shown in Figures W9, W10 in appendix A to this subpart.

(b) The following instrumentation may be required for installation in the dummy for compliance testing. If so, it is installed during qualification procedures as described in this subpart:

(1) The optional angular rate sensors for the head have the dimensions and response characteristics specified in any of drawings SA572-S55, SA572-S56, SA572-S57 or SA572-S58 and are mounted in the head as shown in drawing 020-0100, sheet 2 of 5.

(2) The upper spine accelerometers have the dimensions, response characteristics, and sensitive mass locations specified in drawing SA572-S4 and are mounted in the torso assembly as shown in drawing 020-0100, sheet 2 of 5.

(3) The pelvis accelerometers have the dimensions, response characteristics, and sensitive mass locations specified in drawing SA572-S4 and are mounted in the torso assembly as shown in drawing 020-0100, sheet 2 of 5.

(4) The T1 accelerometer has the dimensions, response characteristics, and sensitive mass location specified in drawing SA572-S4 and is mounted in the torso assembly as shown in drawing 020-0100, sheet 2 of 5.

(5) The lower neck force and moment transducer has the dimensions, response characteristics, and sensitive axis locations specified in drawing SA572-S8 and is mounted to the neck assembly as shown in drawing 020-0100, sheet 2 of 5.

(6) The tilt sensor has the dimensions and response characteristics specified in drawing SA572-S44 and is mounted to the torso assembly as shown in drawing 020-0100, sheet 2 of 5.

(7) The pubic force transducers have the dimensions and response characteristics specified in drawing SA572-S7 and are mounted in the torso assembly as shown in drawing 020-0100, sheet 2 of 5.

(c) The outputs of transducers installed in the dummy and in the test equipment specified by this part are to be recorded in individual data channels that conform to SAE J211 (incorporated by reference, see §572.210) except as noted, with channel frequency classes (CFCs) as follows:

- (1) Pendulum acceleration, CFC 180,
- (2) Pendulum angular rate, CFC 60,
- (3) Neck twist fixture rotation, CFC 60,
- (4) Test probe acceleration, CFC 180,
- (5) Head accelerations, CFC 1000,

- (6) Headform angular rate, CFC 60,
- (7) Neck moments, upper and lower, CFC 600,
- (8) Shoulder deflection, CFC 180,
- (9) Thorax deflection, CFC 180,
- (10) Upper spine accelerations, CFC 180,
- (11) T1 acceleration, CFC 180,
- (12) Pubic force, CFC 180,
- (13) Pelvis accelerations, CFC 1000.

(d) Coordinate signs for instrumentation polarity are to conform to SAE J1733 (incorporated by reference, see §572.210).

(e) The mountings for sensing devices have no resonant frequency less than 3 times the frequency range of the applicable channel class.

(f) Limb joints are set at one G, barely restraining the weight of the limb when it is extended horizontally. The force needed to move a limb segment is not to exceed 2G throughout the range of limb motion.

(g) Performance tests of the same component, segment, assembly, or fully assembled dummy are separated in time by not less than 30 minutes unless otherwise noted.

(h) Surfaces of dummy components may not be painted except as specified in this subpart or in drawings subtended by this subpart.

Appendix A to subpart W of part 572– Figures

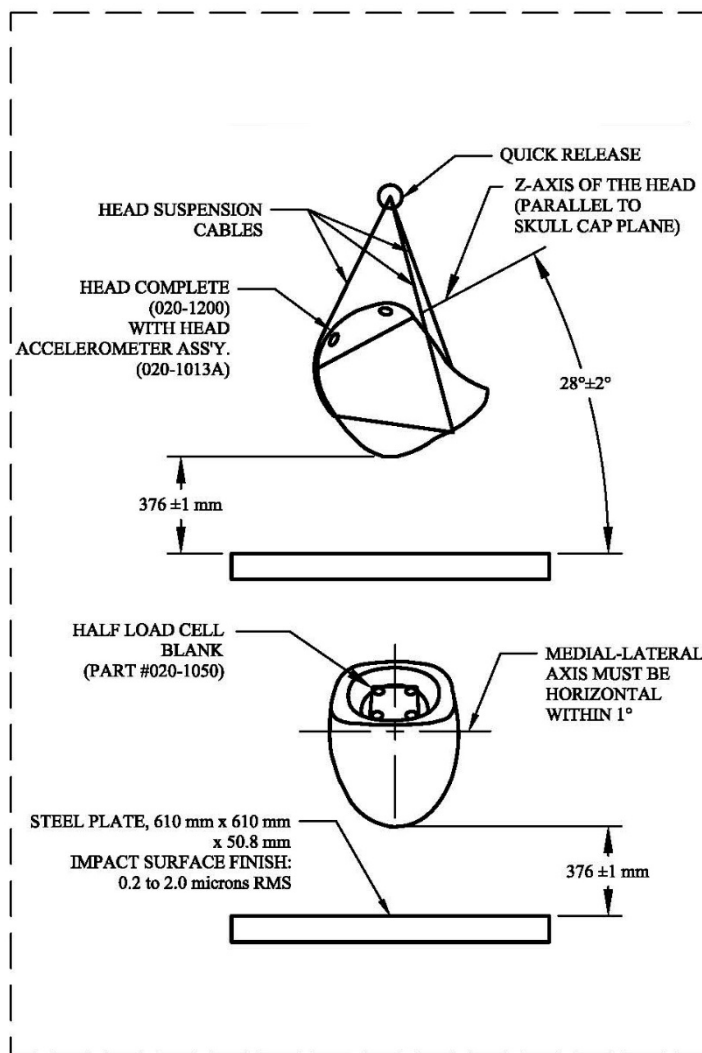

Figure W1. Frontal head drop test set-up specifications.

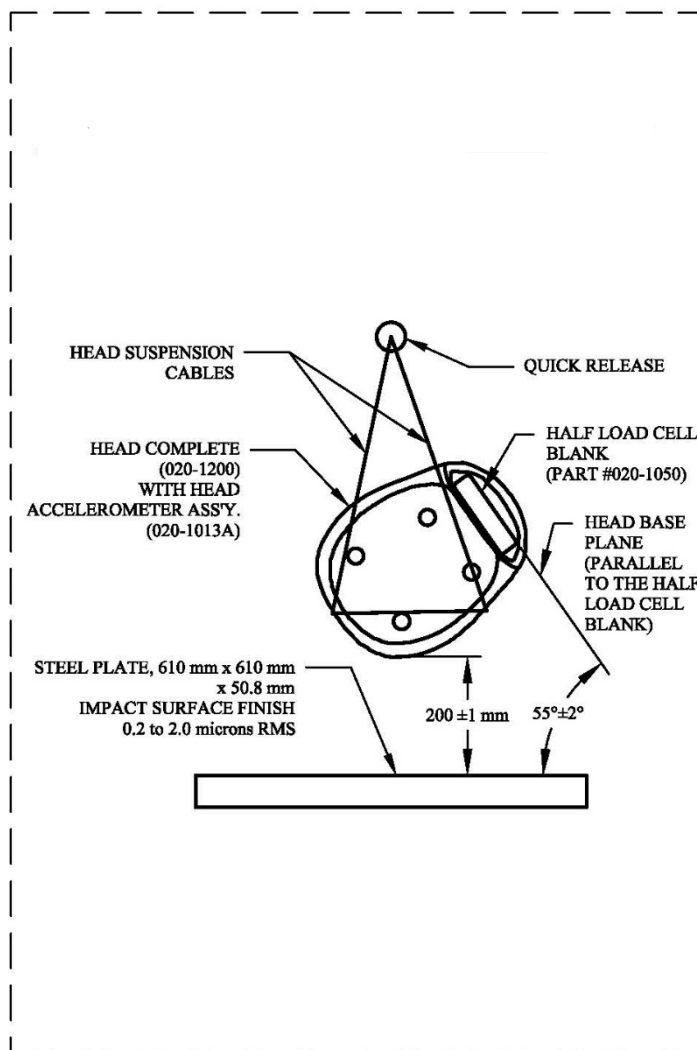

Figure W2. Lateral head drop test set-up specifications.

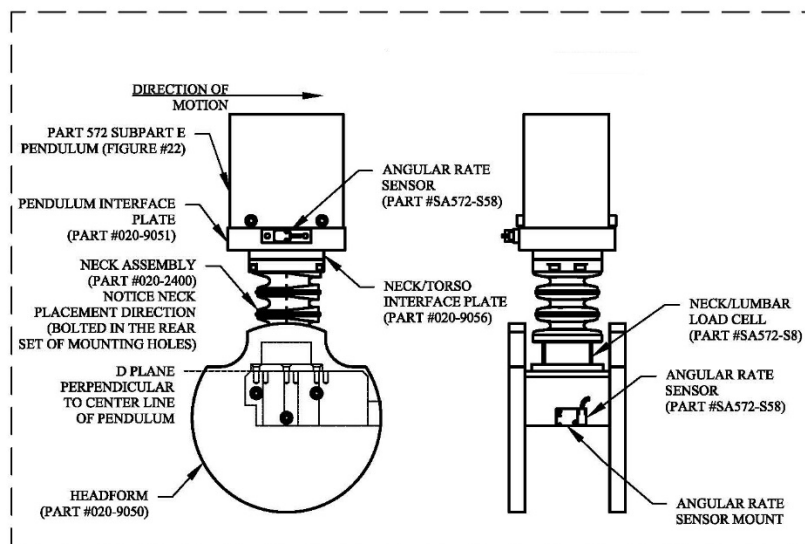

Figure W3. Neck frontal flexion test set-up specifications.

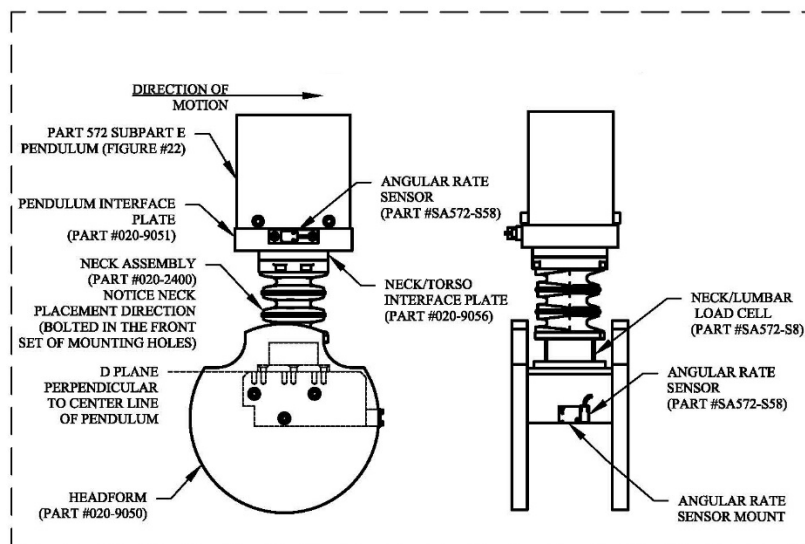

Figure W4. Neck lateral flexion test set-up specifications.

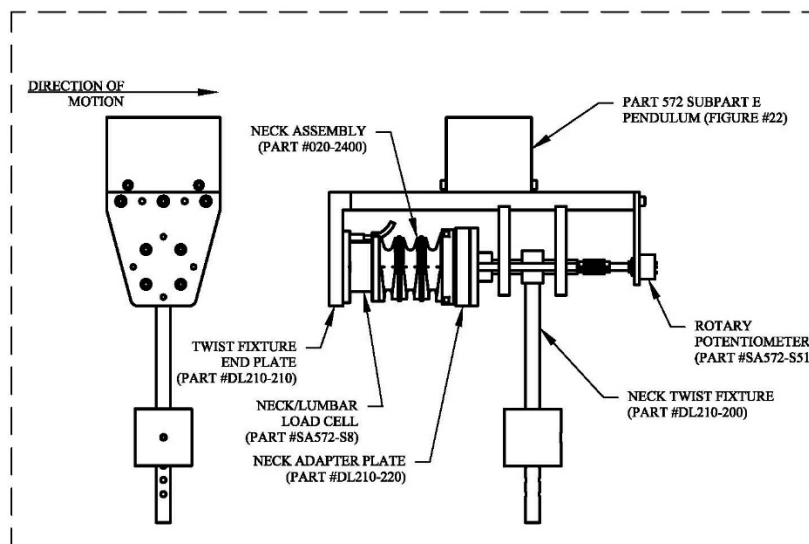

Figure W5. Neck torsion test set-up specifications.

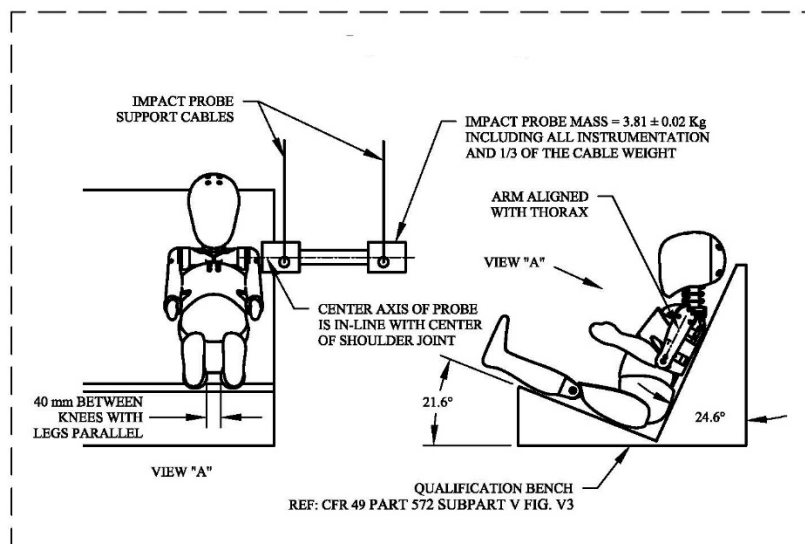

Figure W6. Lateral shoulder impact test set-up specifications.

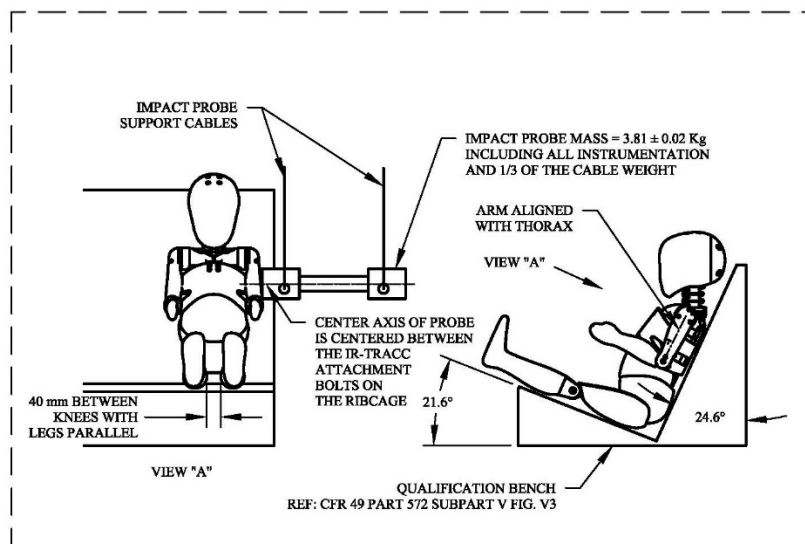

Figure W7. Lateral thorax with arm impact test set-up specifications.

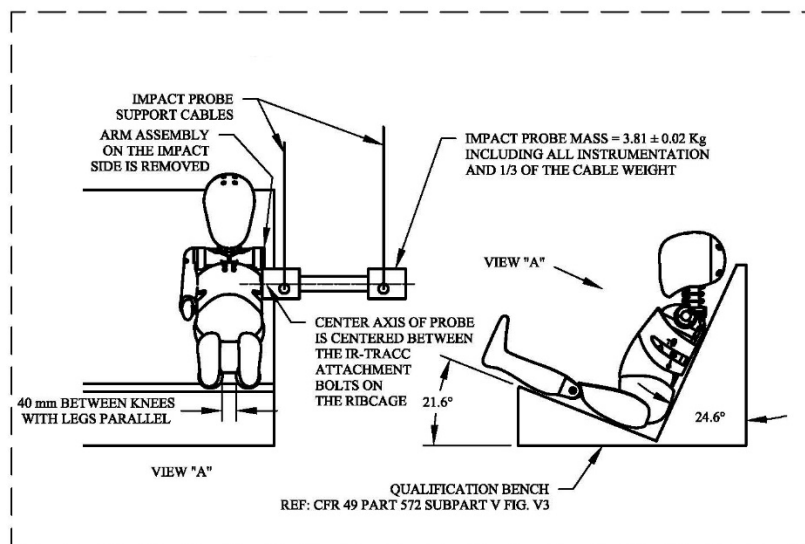

Figure W8. Lateral thorax without arm impact test set-up specifications.

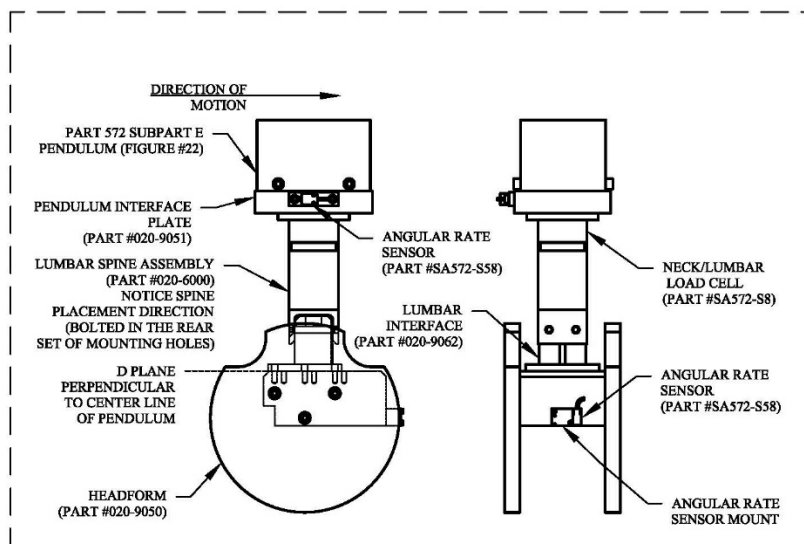

Figure W9. Lumbar frontal flexion test set-up specifications.

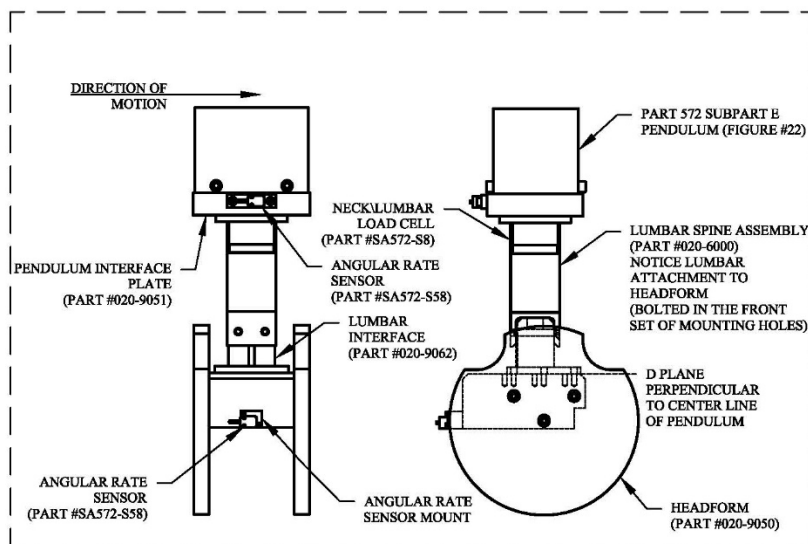

Figure W10. Lumbar lateral flexion test set-up specifications.

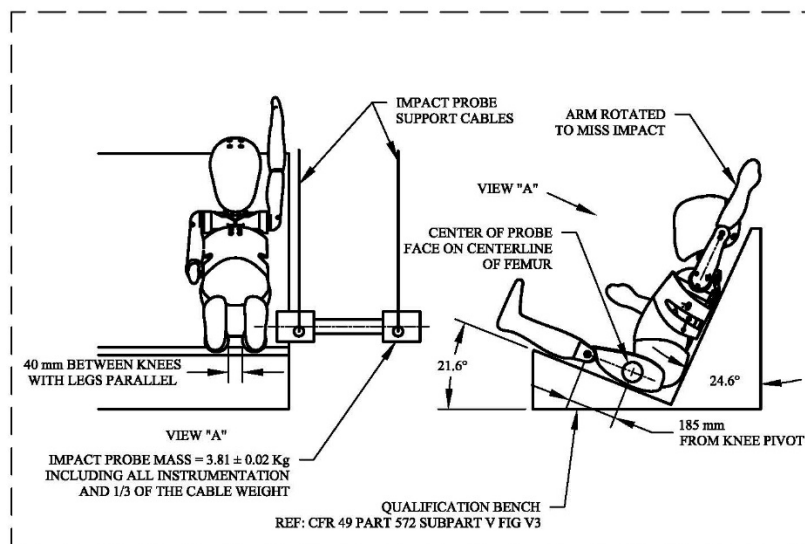

Figure W11. Pelvis lateral impact test set-up specifications.

Authority: 49 U.S.C. 322, 30111, 30115, 30117 and 30166; delegation of authority at 49 CFR 1.95 and 501.4.

Issued on:

James C. Owens
Deputy Administrator

Billing Code: 4910-59-C

[Signature page; Q3s Final Rule, 49 CFR Part 572, RIN 2127-AL04]