

TP-217TB-00
June 25, 2002

U.S. DEPARTMENT OF TRANSPORTATION
NATIONAL HIGHWAY TRAFFIC SAFETY ADMINISTRATION

LABORATORY TEST PROCEDURE

FOR

FMVSS No. 217

Bus Emergency Exits and
Window Retention and Release
(GVWR over 10,000 lb)



ENFORCEMENT
Office of Vehicle Safety Compliance
Room 6111, NVS-220
400 Seventh Street, SW
Washington, DC 20590

REVISION CONTROL LOG
FOR OVSC LABORATORY
TEST PROCEDURES

TP-217TB-00

Bus Emergency Exits and Window Retention and Release

TEST PROCEDURE		FMVSS 217		DESCRIPTION
REV. No.	DATE	AMENDMENT	EFFECTIVE DATE	
00	06/25/02	37FR9394	06/25/02	Original release signed by O.D.
01				
02				
03				
04				
05				
06				
07				
08				
09				
10				

OVSC LABORATORY TEST PROCEDURE No. 217
TABLE OF CONTENTS

	PAGE
1. PURPOSE AND APPLICATION.....	1
2. SECURITY	2
3. GOOD HOUSEKEEPING.....	2
4. TEST SCHEDULING AND MONITORING	3
5. EQUIPMENT AND INSTRUMENTATION	3
6. GOVERNMENT FURNISHED PROPERTY (GFP).....	6
7. CALIBRATION OF TEST INSTRUMENTS.....	7
8. PHOTOGRAPHIC DOCUMENTATION.....	9
9. DEFINITIONS.....	10
10. COMPLIANCE TEST EXECUTION.....	15
11. TEST DATA AND TEST VEHICLE DISPOSITION.....	30
12. REPORTS	30
13. FINAL TEST REPORTS.....	36
13.1 REQUIREMENTS	36
13.2 COPIES.....	36
13.3 FIRST THREE PAGES OF FINAL REPORT	37
13.4 TABLE OF CONTENTS	42
14. DATA SHEETS.....	45
APPENDIX.....	52

1. PURPOSE AND APPLICATION

The Office of Vehicle Safety Compliance (OVSC) provides contractor laboratories with Laboratory Test Procedures as guidelines for obtaining compliance test data. The data are used to determine if a specific vehicle or item of motor vehicle equipment meets the minimum performance requirements of the subject Federal Motor Vehicle Safety Standard (FMVSS). The purpose of the OVSC Laboratory Test Procedures is to present a uniform testing and data recording format, and provide suggestions for the use of specific equipment and procedures. If any contractor views any part of an OVSC Laboratory Test Procedure to be in conflict with a Federal Motor Vehicle Safety Standard (FMVSS) or observes deficiencies in a Laboratory Test Procedure, the contractor is required to advise the Contracting Officer's Technical Representative (COTR) and resolve the discrepancy prior to the start of compliance testing.

Every contractor is required to submit a detailed test procedure to the COTR before initiating the compliance test program. The procedure must include a step-by-step description of the methodology to be used. The contractor's test procedure shall contain a complete listing of test equipment with make and model number and a detailed check-off sheet. The list of test equipment shall include instrument accuracy and calibration dates. All equipment shall be calibrated in accordance with the manufacturer's instructions. There shall be no contradictions between the Laboratory Test Procedure and the contractor's in-house test procedure. Written approval of the in-house test procedures shall be obtained from the COTR before initiating the compliance test program. The OVSC Laboratory Test Procedures are not intended to limit or restrain a contractor from developing or utilizing any testing techniques or equipment which will assist in procuring the required compliance test data. These Laboratory Test Procedures do not constitute an endorsement or recommendation for use of any product or method. However, the application of any such testing technique or equipment is subject to prior approval of the COTR.

NOTE: The OVSC Laboratory Test Procedures, prepared for the limited purpose of use by independent laboratories under contract to conduct compliance tests for the OVSC, are not rules, regulations or NHTSA interpretations regarding the meaning of a FMVSS. The Laboratory Test Procedures are not intended to limit the requirements of the applicable FMVSS(s). In some cases, the OVSC Laboratory Test Procedures do not include all of the various FMVSS minimum performance requirements. Recognizing applicable test tolerances, the Laboratory Test Procedures may specify test conditions that are less severe than the minimum requirements of the standard. In addition, the Laboratory Test Procedures may be modified by

1. PURPOSE AND APPLICATION....Continued

The OVSC at any time without notice, and the COTR may direct or authorize contractors to deviate from these procedures, as long as the tests are performed in a manner consistent with the standard itself and within the scope of the contract. Laboratory Test Procedures may not be relied upon to create any right or benefit in any person. Therefore, compliance of a vehicle or item of motor vehicle equipment is not necessarily guaranteed if the manufacturer limits its certification tests to those described in the OVSC Laboratory Test Procedures.

2. SECURITY

The contractor shall provide appropriate security measures to protect OVSC test vehicles and government furnished property (GFP) from unauthorized personnel during the entire compliance testing program. The contractor is financially responsible for any acts of theft and/or vandalism that occur during storage of test vehicles and GFP. Any security problems that arise shall be reported by telephone to the Industrial Property Manager (IPM), Office of Contracts and Procurement (OCP), within two working days after the incident. A letter containing specific details of the security problem will be sent to the IPM (with copy to the COTR) within 48 hours.

The contractor shall protect and segregate the data that evolve from compliance testing before and after each vehicle test. No information concerning the vehicle safety compliance testing program shall be released to anyone except the COTR, unless specifically authorized by the COTR or the COTR's Branch or Division Chief.

NOTE: NO INDIVIDUALS, OTHER THAN CONTRACTOR PERSONNEL DIRECTLY INVOLVED IN THE COMPLIANCE TESTING PROGRAM OR OVSC PERSONNEL, SHALL BE ALLOWED TO WITNESS ANY VEHICLE COMPLIANCE TEST UNLESS SPECIFICALLY AUTHORIZED BY THE COTR.

3. GOOD HOUSEKEEPING

Contractors shall maintain the entire vehicle compliance testing area, test fixtures, and instrumentation in a neat, clean, and painted condition with test instruments arranged in an orderly manner consistent with good test laboratory housekeeping practices.

4. TEST SCHEDULING AND MONITORING

The contractor shall submit a vehicle test schedule to the COTR prior to testing. Tests shall be completed as required in the contract.

Scheduling of vehicle tests shall be adjusted to permit vehicles to be tested in accordance other FMVSSs, as may be required by the OVSC. All vehicle compliance testing shall be coordinated with the COTR in order to allow monitoring by the COTR and/or other OVSC personnel if desired.

5. EQUIPMENT AND INSTRUMENTATION

The following is a description of the **minimum** equipment and instrumentation needed to conduct tests to the requirements of FMVSS 217:

A. ELLIPSOID

Fabricate an ellipsoid with the dimensions generated by revolving a 33 x 50 centimeters ellipse about the 33 cm minor axis. A suggested method is shown in Figure 1 below.

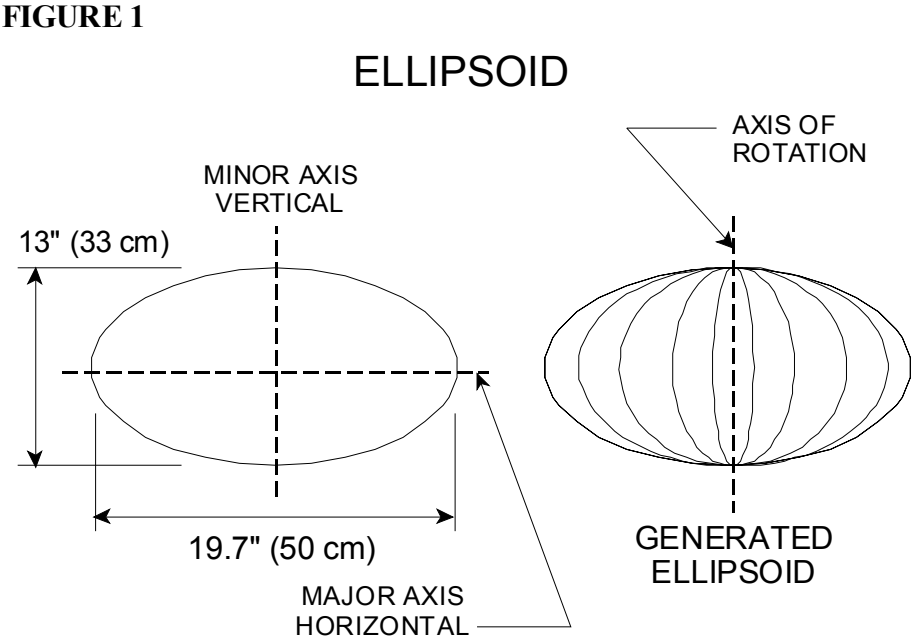

5. EQUIPMENT AND INSTRUMENTATION....Continued

B. EQUIPMENT FOR WINDOW RETENTION TEST

HEAD FORM

The head form will be assembled as shown in Figure 2:

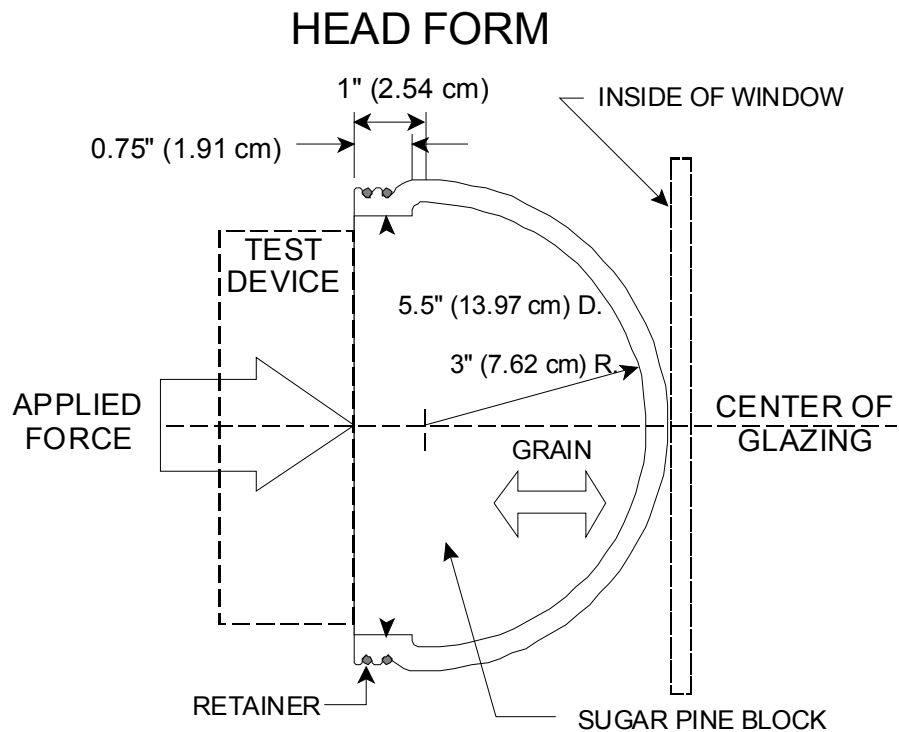

FIGURE 2

- (1) Retainer design is optional.
- (2) The 3.00 inch radius is SPHERICAL.
- (3) The sugar pine block is covered as follows:
 - [a] Underlayer of 0.250 inch thick, plus or minus 0.025 inch; synthetic having a tensile strength of 250 psi, ± 25 psi; and an elongation of 50 percent, $\pm 10\%$.

5. EQUIPMENT AND INSTRUMENTATION...Continued

- [b] Outer layer of NAPA goatskin, wet chamois, or 0.030 inch thick, plus or minus 0.003 inch synthetic skin with a tensile strength of 1000 psi, ± 50 psi and an elongation of 100 percent, ± 5 percent.

C. FOUR INCH TEST SPHERE

Fabricate a 4 inch diameter sphere. Attach a handle to permit repeated attempts to pass the sphere through openings that could appear around the window retaining structure while load is being applied during the window retention tests. The sphere and handle must weigh less than 5 pounds.

D FORCE MEASURING APPARATUS

A calibrated force measuring apparatus (load cell) shall be installed between the head form and the load input device to continuously measure the load rate. The apparatus must be capable of measuring 120 percent of the specified load.

E DISPLACEMENT MEASURING APPARATUS

A calibrated displacement measuring device shall be used to continuously measure the outward (horizontal) displacement of the inner surface of the window glazing at the center of the force application.

F. TEMPERATURE RECORDING DEVICE

A temperature recording device capable of taking continuous, temperature readings between 70° F and 85° F with an accuracy of $\pm 2^\circ$ F. To verify that temperature requirements are met, the device shall provide a permanent visual display of the temperature readings taken over a period of at least 4 hours.

G. LOAD INPUT DEVICE

A device capable of continuously applying a load outward and perpendicular to the inside surface of the window such that the load rate is 2 inches per minute (ipm) ± 0.75 ipm. Controlled or metered hydraulics, pneumatics, or electric screw jacks are examples of acceptable devices.

5. EQUIPMENT AND INSTRUMENTATION....Continued

H. LOAD SYSTEM SUPPORT

A structural framework capable of supporting the load input device, head form and instrumentation. It is recommended that the support be capable of varying in height, width, and length in order to adjust to variations in window size and seat configuration.

I. MEASURING SCALE

Any standard length measuring scale can be used that is not subject to weather or damage effects producing variations that would exceed the specified tolerance.

J. TEST DATA PERMANENT RECORDING INSTRUMENT

A continuous recorder(s) with visual trace is recommended for the recording instrument.

K. FORCE MEASURING DEVICE(S)

To measure the magnitude of force required to release and open (extend) the emergency exit, a force measuring device(s) with a range of at least 445 Newtons and an indicator for peak force readings, shall be used. The force measuring device(s) shall be capable of accurately measuring release forces and extension forces for each type of motion outlined in Section 10.6 of this test procedure.

6. GOVERNMENT FURNISHED PROPERTY (GFP)

6.1 ACCEPTANCE OF TEST VEHICLES

The Contractor is responsible for accepting test vehicles from either dealers or vehicle transporters. In both instances, the contractor acts in the OVSC's behalf when signing an acceptance of test vehicles. If a vehicle is delivered by a dealer, the contractor must check to verify the following:

- A. All options listed on the "window sticker" are present on the test vehicle.
- B. Tires and wheel rims are new and the same as listed.
- C. There are no dents or other interior or exterior flaws.

6. GOVERNMENT FURNISHED PROPERTY (GFP)...continued

- D. The vehicle has been properly prepared and is in running condition.
- E. The glove box contains an owner's manual, warranty document, consumer information, and extra set of keys.
- F. Proper fuel filler cap is supplied on the test vehicle.

If a test vehicle is delivered by a government contracted transporter, the contractor shall check for damage which may have occurred during transit. A "Vehicle Condition" form (see Section 12.3) will be supplied to the contractor by the COTR when a test vehicle is transferred from a new vehicle dealer or between test contracts. The upper half of the form describes the vehicle in detail, and the lower half provides space for a detailed description of the post test condition. Vehicle condition forms must be returned to the COTR with the copies of the final test report, or the reports will NOT be accepted.

6.2 NOTIFICATION OF COTR

A. Vehicle Delivery

The COTR must be notified within 24 hours after a vehicle has been delivered.

B. Notification of Failure

The COTR must be notified within 24 hours after the event of a test failure, i.e. requirements of the standard not met.

7. CALIBRATION OF TEST INSTRUMENTS

Before beginning the safety compliance test program, the contractor must implement and maintain a test instrumentation calibration system in accordance with established calibration practices. Guidelines for setting up and maintaining such calibration systems appear in MIL-C-45662A, "Calibration System Requirements". The calibration system shall be set up and maintained as follows:

- A. Standards for calibrating the measuring and test equipment will be stored and used under appropriate environmental conditions to assure their accuracy and stability.

7. CALIBRATION OF TEST INSTRUMENTS....Continued

- B. All measuring instruments and standards shall be calibrated by the contractor, or by a commercial facility, against a higher order standard at periodic intervals NOT TO EXCEED TWELVE (12) MONTHS! Records, showing the calibration traceability to the National Institute for Standards and Technology (NIST), shall be maintained for all measuring and test equipment.
- C. All measuring and test equipment and measuring standards will be labeled with the following information:
 - (1) Date of calibration
 - (2) Date of next scheduled calibration
 - (3) Name of the technician who calibrated the equipment
- D. The contractor shall provide a written calibration procedure that includes as a minimum the following information for all measurement and test equipment:
 - (1) Type of equipment, manufacturer, model number, etc.
 - (2) Measurement range
 - (3) Accuracy
 - (4) Calibration interval
 - (5) Type of standard used to calibrate the equipment (calibration traceability of the standard must be evident)
- E. The contractor shall keep records of calibration for all test instrumentation in a manner that assures the maintenance of established calibration schedules. All such records shall be readily available for inspection when requested by the COTR. The calibration procedure must be approved by the COTR before the test program commences.

7. CALIBRATION OF TEST INSTRUMENTS....Continued

TEST EQUIPMENT ACCURACY

ITEM	RANGE	ACCURACY
Load Input Device (Hydraulic Actuator or equivalent)	0 to 22,240 Newtons	N/A (NO slippage or leakage)
*Force Transducer (Load Cell or equivalent)	0 to 6,672 Newtons	± 1% (± 67 Newtons)
*Displacement Measuring Device (Linear Pot. or equivalent)	0 to 10 inches	" 0.1 inch
*Continuous Recorder of 5% of Max. Load	Readout capability	+2%
*DC Power Supply units attached	Adequate power for 0.05% @ 105-125v load regulation, 0.05% @ Full Load STABILITY - 0.1%	Line regulation
*Signal Conditioning and Calibration Unit (for calibration of Load Cell and Linear) Potentiometer used in test	Capable of providing signal conditioning	± 0.5%
Digital Voltmeter or equivalent (to monitor or check load cell or linear potentiometer output)	Minimum of 4-digit readout	± 0.1%
Hand Held Force Gauge (with follower needle)	0 to 445 Newtons	± 1% F.S.
Tension or Compression Scale (with follower needle)	0 to 445 Newtons	± 1% F.S.
Temperature Recorder	0 to 150 ° F	± 2° F

*It is recommended that the total system be calibrated as a unit, and that system accuracy be ± 89 Newtons.

8. PHOTOGRAPHIC DOCUMENTATION

Photographs shall be glossy black and white or color, 8 inches x 10 inches, and properly focused for clear images. A legible label or placard identifying the test vehicle model, NHTSA number, and date shall appear in each photograph.

As a minimum, each vehicle final test report shall include the following photographs:

8. PHOTOGRAPHIC DOCUMENTATION....Continued

A. Exterior Photographs

1. Front view
2. Right side view
3. Left side of vehicle
4. Rear view

B. Interior Photographs

1. Rear view depicting seating arrangement
2. Front view depicting seating arrangement
3. Views of each type of exit identification label, exit instruction label or referral label
4. Vehicle's certification label and tire information label, if separate
5. View of ellipsoid clearance of emergency exits
6. Pretest and post test view(s) of windows in retention test
7. Views of each type of emergency exit
8. View of loading fixture and all instrumentation used for window retention test
9. View(s) of window retention tests in progress

9. DEFINITIONS

ADJACENT SEAT

A designated seating position located so that some portion of its occupant space is not more than 25 centimeters from an emergency exit, for a distance of at least 38 centimeters measured horizontally and parallel to the exit

9. DEFINITIONS...Continued

ADJOINING SEAT

A designated seating position located next to an adjacent seat

AUDIBLE ALARM

A sound that can be heard at each emergency door, and at the driver's position, when the ignition is on and the release mechanism of any emergency door is not closed

BUS

A motor vehicle with motive power, except a trailer, designed for carrying more than 10 persons

CONCISE OPERATING INSTRUCTIONS

Label(s) must indicate all the motions required to unlatch and extend the emergency exit.

DESIGNATED SEATING POSITION

Any plan view location capable of accommodating a person at least as large as a 5th percentile adult female, if the overall seat configuration and design and vehicle design is such that the position is likely to be used as a seating position while the vehicle is in motion, except for auxiliary seating accommodations such as temporary or folding jump seats

DESIGNATED SEATING CAPACITY

The number of designated seating positions, including the driver's seat

EIGHTY (80) PERCENT OF GLAZING THICKNESS

(Defined as 80 percent of the TOTAL thickness) If it is a single pane, use 80 percent of its thickness. If it is a dual pane safety plate with a vinyl insert, use 80 percent of the total thickness. If it is a window designed with an airspace between two panes, use 80 percent of the total thickness of both panes excluding the airspace.

9. DEFINITIONS...Continued**ELLIPSOID**

A volume generated by revolving the perimeter of an ellipse about its minor axis of 33 centimeters (see Figure 1). The major axis is noted as 50 centimeters.

EMERGENCY EXIT

Any designated areas of egress such as a push out window, a door, or a roof exit that meets the criteria of the standard.

HEAD FORM TRAVEL TO 2 INCHES PER MINUTE (IPM)

The headform force and headform displacement shall each be permanently recorded. Rate of travel of the force media shall be nominally 2 ipm with an acceptable tolerance of plus or minus 0.75 ipm.

INTERLOCK

A mechanism that prevents starting the school bus engine until the emergency exit door(s) have been unlocked (from inside or outside) by a key, a combination, or operation of a remote switch

LEGIBILITY

Capable of being read or deciphered

LOCKED (INTERLOCK)

The release mechanism cannot be activated by a person at the door without a special device such as a key, or special information such as a combination.

MIDPOINT OF THE PASSENGER COMPARTMENT

Any point on a vertical transverse plane bisecting a line that is parallel to the vehicle centerline and that extends between the two vertical transverse planes defining the foremost and rearmost limits of the passenger compartment

9. DEFINITIONS...Continued

MOTION

Any action, which has direction and force, used to release the emergency exit. The motion may be rotary, straight, upward, downward, inward, forward, rearward, rotational, or any combination of these. When used to extend the emergency exit, the motion is a push pull action, and in most cases will be straight and perpendicular to the unobstructed exit surface.

OCCUPANT

A person at least as large as a 5th-percentile adult female.

OCCUPANT SPACE

The space directly above the seat and footwell, bounded vertically by the ceiling and horizontally by the normally positioned seatback and the nearest obstruction of occupant motion in the direction the seat faces.

PASSENGER COMPARTMENT

Space within the school bus interior that is between a vertical transverse plane located 76 cm in front of the forwardmost passenger seating reference point, and a vertical transverse plane tangent to the rear interior wall of the bus at the vehicle centerline.

POST AND ROOF BOW PANEL SPACE

The area between two adjacent post and roof bows.

"PUSH OUT WINDOW"

A vehicle window designed to open outward (usually perpendicular to the exit surface) to provide for emergency egress.

REACH DISTANCE

This term refers to the space envelopes shown on the various Figures included in this test procedure. All movements required to release and open the emergency exits must occur within the space envelopes.

9. DEFINITIONS...Continued

REAR EXIT

An exit installed in the rear half of the passenger compartment.

REAR HALF OF THE BUS

The rear half of the passenger compartment.

REMOTE CONTROLS OR CENTRAL POWER SYSTEM

Some buses have at the driver's station remote controls or central controls to quickly release and/or open each emergency exit. These central systems are considered secondary controls, the primary exit release and opening mechanism being on or at the emergency exit. The release located at the emergency exit must be able to override the central control system within the applied force limitations.

ROOF EXIT

An exit installed in the ceiling or roof of the passenger compartment and located between the side walls

ROTARY FORCE (MOTION)

If the primary motion of the unlatching mechanism is a rotating shaft or hub, then the mechanism release force is termed "rotary motion" even though a long one sided handle moves through a small arc.

SIDE EXIT

An exit installed in the side wall of the bus passenger compartment between the floor and ceiling

SLIDING WINDOW

A bus window designed to open by moving vertically or horizontally to provide for emergency egress

STRAIGHT FORCE (MOTION)

The type of force that would be applied to a sliding bolt or pin; load that operates in one direction only

9. DEFINITIONS...Continued

WINDOW DISPLACEMENT

Before applying any force to the window using the head form, a zero must be established with the head form in initial contact with undisturbed glazing surface.

WINDOW RETENTION FORCE

The total pounds of force applied using a device or apparatus that will provide a nominal force application rate of 2 ipm, plus or minus 0.75 ipm.

WINDOW TEST PANEL OR AREA

If an occupant's window assembly consists of one uninterrupted glazed surface, the test point shall be the center of the glazed surface. If the window assembly consists of a two part glazed surface (usually one part moveable for ventilation), then each separate panel must be tested for retention. The two panels are not tested simultaneously.

10. COMPLIANCE TEST EXECUTION

10.1 PRETEST CONDITIONS

- A. A clean storage area maintained in accordance with good housekeeping standards will be used for storage of test vehicle(s) during any non-testing period. Vehicle(s) shall be properly protected from any conditions which would impair the test program or cause damage to test vehicle(s).
- B. Upon receipt at the test laboratory, properly identify each vehicle with the assigned NHTSA number supplied by the COTR.
- C. Inspect the vehicle's interior and exterior, including all windows, seats, doors, etc., to confirm that each system is complete and functional per the manufacturer's specifications. Any damage, misadjustment, or other unusual condition that could influence the test program or test results shall be recorded on the Report of Condition form. The NHTSA COTR shall be notified of any abnormal condition(s) that may affect the test results before beginning any test.

10. COMPLIANCE TEST EXECUTION....Continued

- D. Place vehicle on a flat, horizontal floor surface.
- E. Photograph the vehicle's certification label. Record the appropriate information on data sheets.
- F. Check the vehicle's tire pressure and, if necessary, adjust to recommended operating pressures.
- G. The inside and outside of the vehicle are kept at any temperature from 70° F to 85° F for a minimum of 4 hours immediately preceding the tests as well as during the tests.
- H. For window retention test, windows are installed, closed and latched (where latches are provided) in the condition intended for normal bus operation.
- I. For the emergency exit release and extension tests, windows are installed as in H., seats, armrests, and interior objects near the windows are installed as for normal use, and adjustable seats are in the upright position.

10.2 PROVISION OF EMERGENCY EXITS (S5.2, S5.2.2.1, S5.2.2.2, S5.2.2.3)

Buses over 10,000 lb GVWR must provide side emergency exits at least one rear emergency exit. If the bus is configured such that it precludes an accessible rear emergency exit, a roof emergency exit shall be provided in the rear half of the bus.

- A. Copy the designated seating capacity (DSC) from the vehicle's tire placard. If the designated seating capacity is not listed on the placard, count the total number of designated seating positions (DSPs) in the bus, including the driver's position. Record on Data Sheet No. 2.
- B. Calculate the **Total Required Area** by multiplying the DSC or (DSPs) by 432 square centimeters. Record on Data Sheet No. 2.
- C. Identify all marked emergency exit openings on front, sides, rear and roof of bus. Draw a schematic of the bus floor plan indicating the location of each exit. Measure the height and width of each exit opening. Do not include the frame of the exit or areas that are obstructed or preclude free passage in the measurement of exit opening. Record information on Data Sheet No. 2.

10. COMPLIANCE TEST EXECUTION....Continued

- D. Calculate the **Actual Exit Area Measured** (height X width) for each exit. Record on Data Sheet No. 2.
- E. Calculate the **Maximum Credit Area Allowed** for each exit. No exit shall be credited with more than 3,458 cm². If the **Actual Exit Area Measured** is greater than 3,458 cm², the **Maximum Credit Area Allowed** is 3,458 cm², otherwise, the **Maximum Credit Area Allowed** is equal to the **Actual Exit Area Measured**. Record on Data Sheet No. 2.
- F. Calculate the **Total Credit Area** by adding together the **Maximum Credit Area Allowed** for all exits. Record on Data Sheet No. 2.
- G. Determine whether the bus complies with the exit area requirements. If the **Total Credit Area** is greater than or equal to the **Total Required Area**, the bus meets the requirement. Indicate PASS or FAIL on Data Sheet No. 2.
- H. Determine whether the bus has the proper distribution of exit area on its right and left sides. Separately, calculate the **Total Credit Area** for exits located on the right and left sides of the bus by adding together the **Maximum Credit Area Allowed** for all exits on the right side and then all exits on the left side. Record on Data Sheet No. 2. Multiply the **Total Required Area** by 0.40. **The Total Credit Area** for each side must be equal to or exceed this area. Indicate Pass or Fail on Data Sheet No. 2.

10.3 EMERGENCY EXIT RELEASE (S5.3, S5.3.1, S5.3.2) (see APPENDIX)

Each emergency exit shall be releasable from inside the bus passenger compartment by operating one or two mechanisms located within the LOW FORCE or HIGH FORCE access regions specified in Figures 3 thru 10. If the motion to release the exit falls entirely within the LOW FORCE access region, the motion must be rotary or straight (not perpendicular to the undisturbed exit surface) and the average peak force shall not exceed 89 Newtons (20 lb). If the motion to release the exit falls entirely within the HIGH FORCE access region, the motion must be straight (perpendicular to the undisturbed exit surface) and the average peak force shall not exceed 267 Newtons (60 lb). (See Appendix, Interpretation letter dated June 13, 1994).

NOTE- Additional Instructions for Determining Compliance-

If the mechanism is located within both the high and low force access regions, the permissible force is 267 Newtons (60 lb) if the type of operating motion is straight, perpendicular to the undisturbed exit surface; the permissible force is 89 Newtons (20 lb) if the type of operating motion is rotary or straight, but not perpendicular to the undisturbed exit surface. (See Appendix, memorandum dated September 15, 1994).

10. COMPLIANCE TEST EXECUTION....Continued

A. Determine Access Regions for Exit Release

- i. Mark on the schematic the location and number of release mechanisms (1 or 2) for each emergency exit and determine whether each release mechanism lies in a LOW FORCE or HIGH FORCE access region in accordance with Figures 3 thru 10. Record on Data Sheet No. 3.
- ii. Operate each release mechanism two to three times. For exits with two release mechanisms, determine whether each mechanism requires one force application to release the exit. Determine the motion necessary to operate each release mechanism (either rotary, straight, not perpendicular to the undisturbed exit surface OR straight, perpendicular to the undisturbed exit surface). Verify whether the motion to release each exit conforms with the motion required to release the exit based on its access region location. Record on Data Sheet No. 3.

B. Force Tests to Release (Unlatch) the Exit

- i. Attach a force measuring device to the release mechanism's handle, lever, knob, etc. Measure the peak force that occurs during the entire movement of the release mechanism up to the point at which the exit releases or becomes unlatched. Record on Data Sheet No. 3.

NOTE - If the operating motion fails to fully unlatch the exit, record the peak force that occurred during the entire travel of the release mechanism or to the point at which the exit would free itself if an extension force is applied.

- ii. Repeat the force tests three times and average the peak force measurements. Determine whether average peak force exceeds the maximum force requirement. Record results on Data Sheet No. 3.

10.4 EMERGENCY EXIT OPENING (S.5.4, S5.4.1)

After the release mechanism has been operated, using the reach distances and corresponding force levels for exit release, each emergency exit shall allow manual opening to a position that provides an opening large enough to admit passage of an 33 by 50 cm ellipsoid, keeping a major axis horizontal at all times.

10. COMPLIANCE TEST EXECUTION....Continued

If the motion to open the exit falls entirely within the LOW FORCE access region, the motion must be rotary or straight and the average peak force shall not exceed 89 Newtons (20 lb). If the motion to open the exit falls entirely within the HIGH FORCE access region, the motion must be straight, perpendicular to the undisturbed exit surface and the average peak force shall not exceed 267 Newtons (60 lb). The direction of the motion to open the exit must differ from the direction of the release motion by not less than 90° and no more than 180°.

NOTE: Additional Instructions for Determining Compliance -

If the portion of the exit in the immediate area of the release mechanism is within both the high and low force areas, the permissible force is 267newtons (60 lb), if the type of extending motion is straight, perpendicular to the undisturbed exit surface; the permissible force is 89 Newtons (20 lb) if the type of extending motion is rotary or straight, but not perpendicular to the undisturbed exit surface.

A. Determine Access Regions for Exit Opening

- i. Mark the area on the exit where the manufacturer has specified for forces to be applied to extend or open the exit. If the manufacturer has not provided data, mark a place on the emergency exit that is in close proximity to one of the release mechanisms. Determine whether the area lies in a LOW FORCE or HIGH FORCE access region in accordance with Figures 3 thru 10. Record on Data Sheet No. 4.
- ii. Operate the exit by extending it two or three times. Determine the motion and its direction necessary to open each exit (either rotary, straight, not perpendicular to the undisturbed exit surface OR straight, perpendicular to the undisturbed exit surface). Verify whether the motion and its direction to release each exit conforms with the motion and direction required to release the exit based on its access region location and the direction of motion for its release. Record on Data Sheet No. 3.

B. Force Tests to Open (Extend) the Exit

- i. Determine whether the ellipsoid passes freely (unobstructed) through each opened emergency exit. If not, indicate FAIL on Data Sheet No. 4. End test (do not conduct force tests to open the exit)

10. COMPLIANCE TEST EXECUTION....Continued

- ii. Attach a force measuring device to the location where the extension force will be applied. Extend the exit and measure the peak force that occurs during its entire movement up to the point at which the ellipsoid will pass without obstruction. Record on Data Sheet No. 4.
- iii. Repeat the force tests two additional times. Average the three peak force measurements to determine whether the exit meets the requirement. Record results on Data Sheet No. 4.

10. COMPLIANCE TEST EXECUTION...Continued

LOW FORCE ACCESS REGIONS
FOR EMERGENCY EXITS HAVING ADJACENT SEATS

FIGURE 3

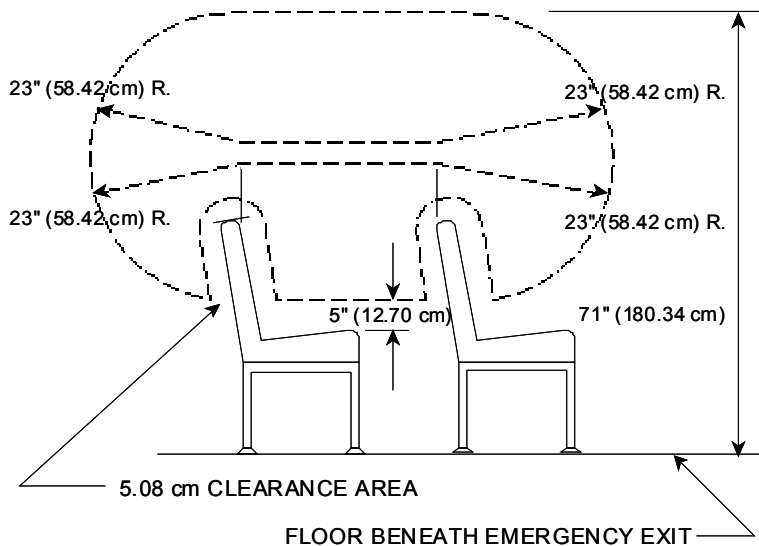
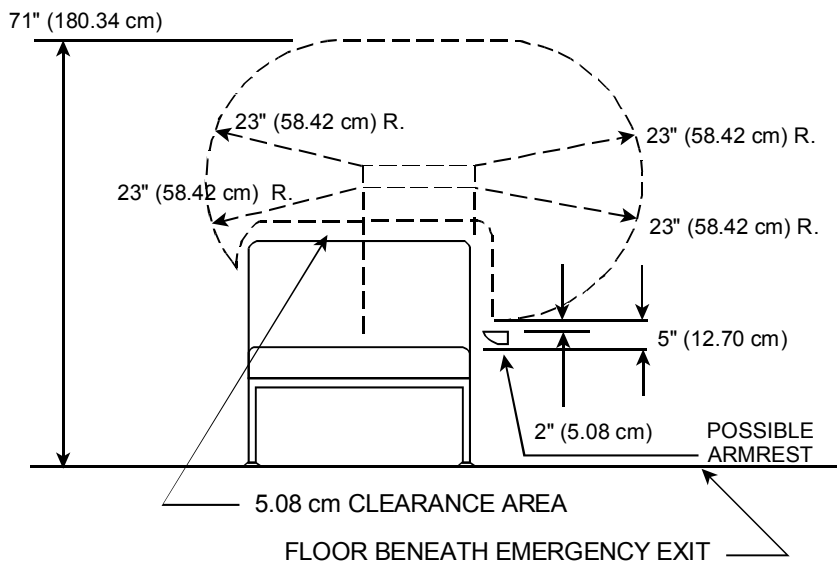

FIGURE 4



10. COMPLIANCE TEST EXECUTION...Continued

HIGH FORCE ACCESS REGIONS FOR EMERGENCY EXITS HAVING ADJACENT SEATS

FIGURE 5

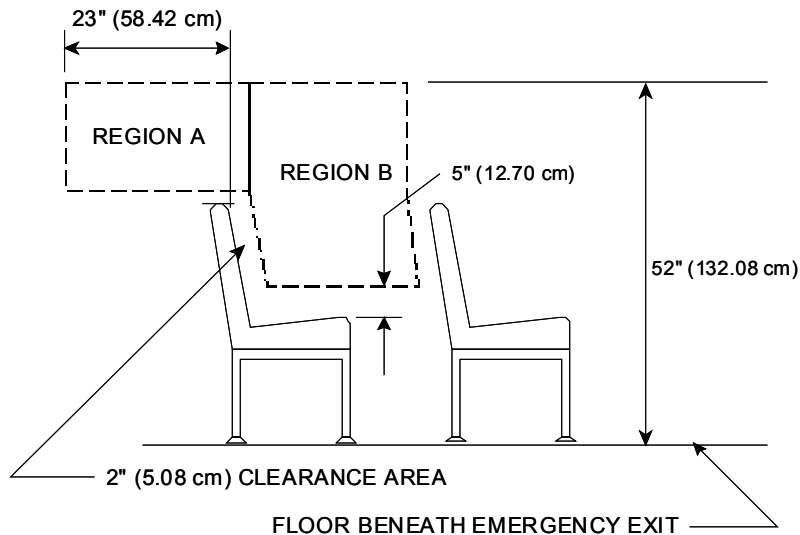
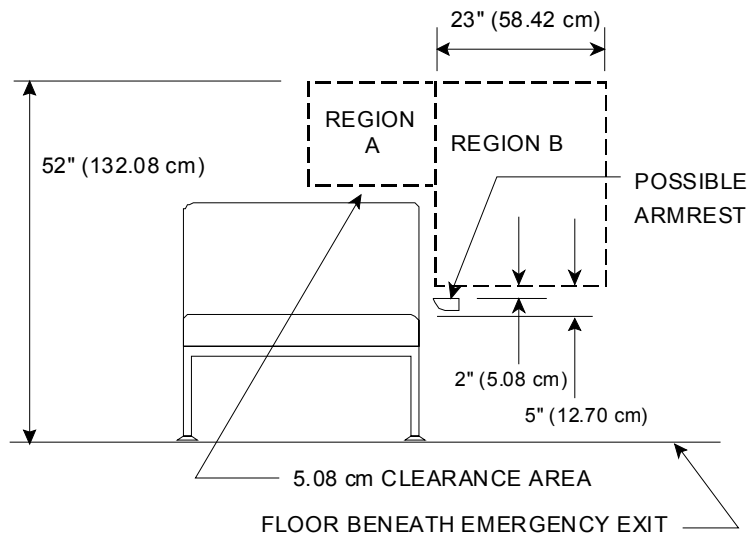

FIGURE 6



10. COMPLIANCE TEST EXECUTION...Continued

FIGURE 7

REAR EMERGENCY EXIT WITHOUT REAR OBSTRUCTION

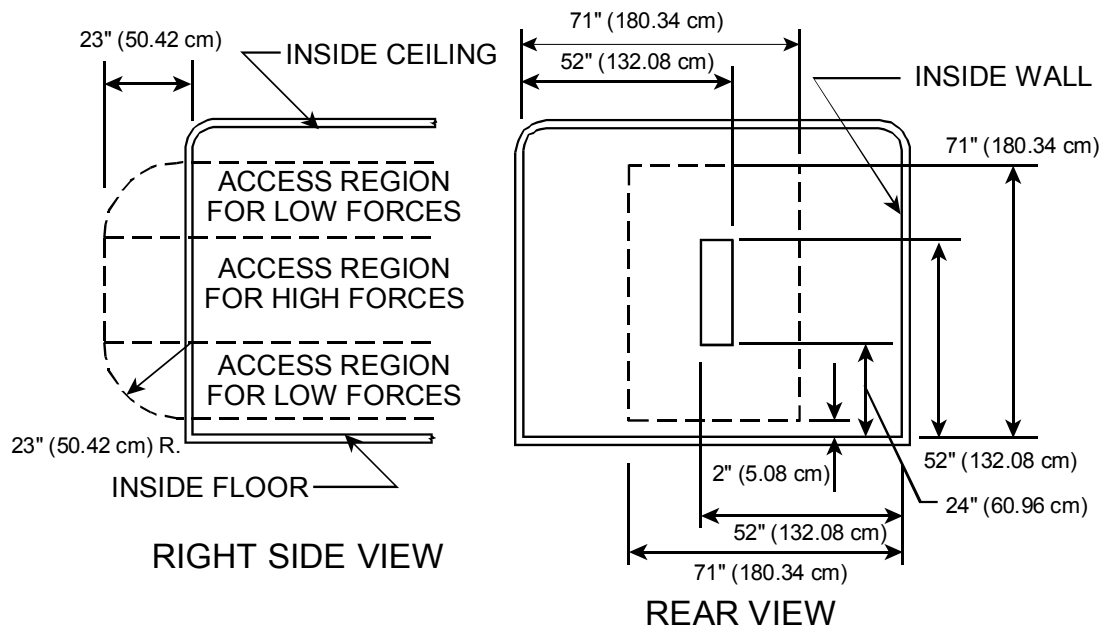
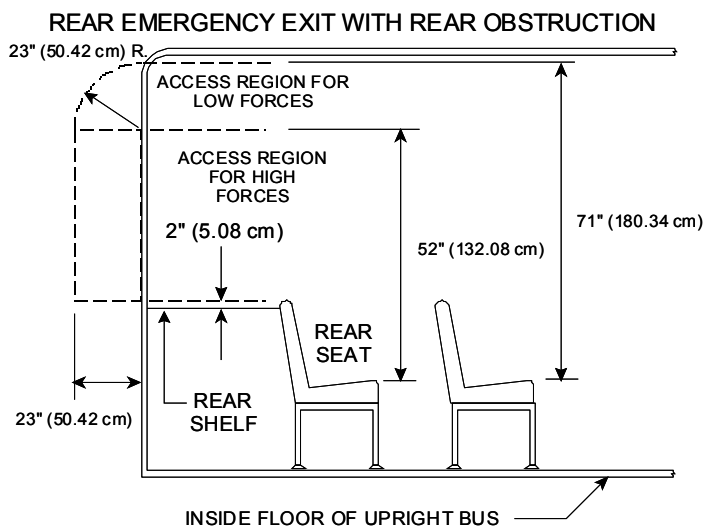

FIGURE 8



10. COMPLIANCE TEST EXECUTION...Continued

FIGURE 9

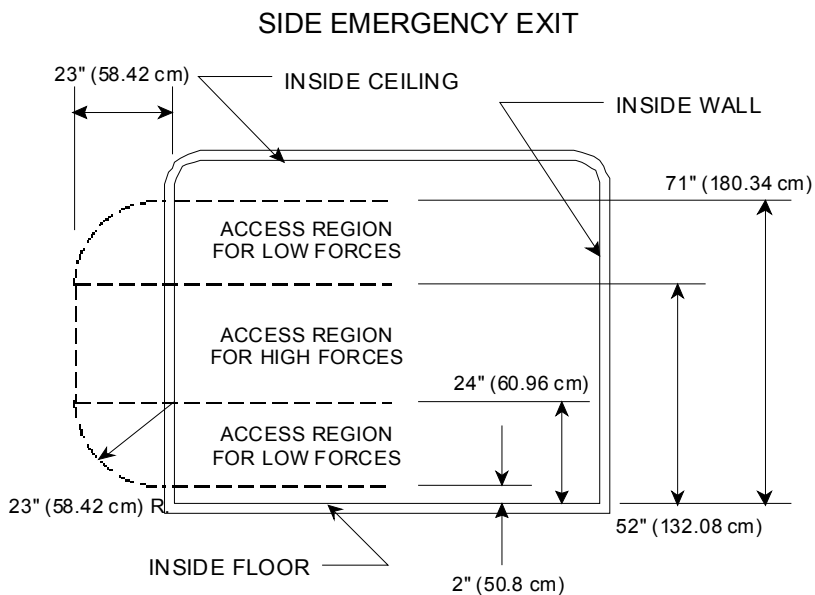
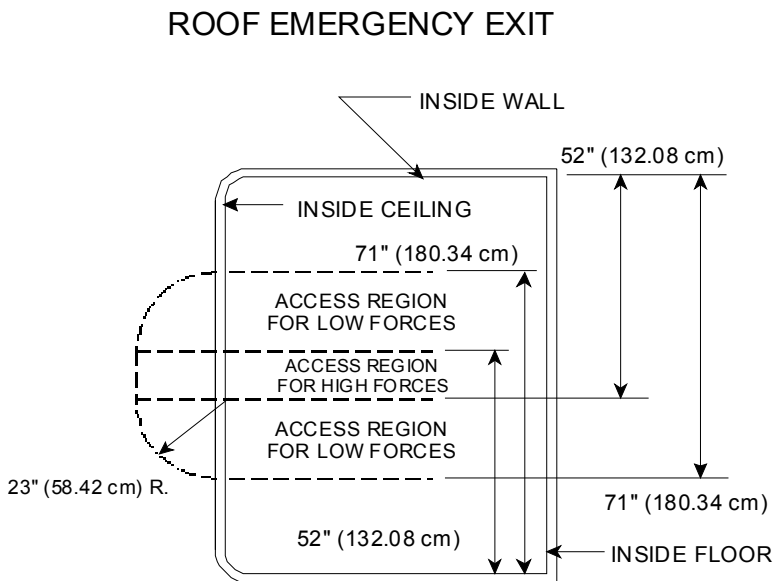

FIGURE 10



10. COMPLIANCE TEST EXECUTION....Continued

10.5 EMERGENCY EXIT IDENTIFICATION (S5.5, S5.5.1, S5.5.2)

For buses with a GVWR over 10,000 lb, each emergency exit door shall have the designation “Emergency Door” or “Emergency Exit.” All other emergency exits shall have the designation “Emergency Exit” followed by concise operating instructions describing the motion necessary to unlatch and open the exit, located within 16 cm of the release mechanism. When a release mechanism is not located within an occupant space of an adjacent seat, a label that indicates the location of the nearest emergency exit must be placed within the occupant space. All labels and placards must be permanently affixed and legible.

1. Emergency Exit Marking and Labeling
 - i. Give a description of each type of designation. Include the exact wording used, the size of the label or placard, the size of the lettering and where it is placed on the exit. Record on Data Sheet No. 5.
 - ii. Verify that each emergency exit has a permanently affixed, legible label or placard with the designation “Emergency Door” or “Emergency Exit.” Record results on Data Sheet No. 5.
 - iii. Verify that each emergency exit has a permanently affixed, legible label or placard describing the motion necessary to unlatch and open the exit. Measure the distance from the midpoint of the label or placard to the midpoint of the nearest release mechanism. Record results on Data Sheet No. 5.
 - iv. For buses equipped with adjacent seats, determine whether an emergency exit release mechanism is within the occupant space. If not, verify that a permanently affixed, legible label or placard has been placed within the occupant space to indicate the location of the nearest release mechanism. Record results on Data Sheet No. 5.

10. COMPLIANCE TEST EXECUTION....Continued

10.6 WINDOW RETENTION TEST

- A. Select the window for retention test. If window is a two part assembly, each panel will be tested separately. This would require testing another window assembly.
- B. Provide a detailed description of the window, such as fixed, push out, single or double glazed, or vertical sliding, etc. Record on Data Sheet 6.
- C. Measure the window and record data of each panel size on Data Sheet 6 (windows with less than an 8 inch horizontal or vertical dimension do not apply).
- D. Exercise window exit release mechanism and extension. Check for proper action.
- E. Close and latch the window being tested as well as the two adjacent windows. Double check for proper lock position.
- F. Adjust position of load input device to achieve a "zero position" at center of window to be tested with head form, so that it will push outward and perpendicular to the undisturbed inside surface and is lightly touching the undisturbed inner glazing surface.
- G. Connect the calibrated load cell and displacement measuring device(s) to the power supply, signal conditioning and recording system. Set zero position and slope of force line to achieve a nominal 2 ipm (± 0.75 imp) displacement rate. Record zero settings.
- H. Photograph test setup.
- I. Turn on recorder and run zero position data and turn off.

10. COMPLIANCE TEST EXECUTION....Continued

- J. Mark slope of force data trace to achieve a nominal 2 ipm rate of movement of head form. The plot shall note the minimum/maximum limits plus maximum travel of head form (see Figure 18). Also, on a separate plot, mark the 1200 pound force limit as well as the maximum displacement **D** permitted by the formula:

$$D' \frac{\sqrt{L}}{2}$$

where: D = Window panel displacement

L = minimum horizontal or vertical surface dimension of the window panel (in inches) measured through the center of the area of the entire sheet of window glazing

- K. Turn power source, recorder and plotters on and start test. Apply power continuously until one of the following three limits is achieved:
- (1) 1200 pounds force is reached.
 - (2) Shattering of the glazing occurs (or at least 80% of the glazing thickness has developed cracks running from the load contact region to the periphery at two or more points).
 - (3) The maximum displacement **D** is achieved.
- L. Continuously check large openings forming about the structure by attempts at passing the 4-in. sphere through the opening. Apply no more than 5 pounds of force at each attempted pass.
- M. **PASS/FAIL Criteria:** If the window retention structure fails before any of the limits of Item J are attained, it is considered a failure. If the window structure withstands the force and any one of the three items of Item J is attained, it is considered a pass. If one panel of a two panel window assembly fails to pass, the entire window assembly is a FAIL.
- N. Photograph test in progress.
- O. If the window is two panel assembly, repeat steps C through K above for the other panel. This would require testing another window position because of the interaction of the two window halves.
- P. Terminate the tests and photograph the results.

10. COMPLIANCE TEST EXECUTION....Continued

- Q. Remove load support fixture, and repeat the force tests to unlatch and open the emergency exits in accordance with Sections 10.3 and 10.4.
- R. Record results on Data Sheet 6.

10. COMPLIANCE TEST EXECUTION...Continued

WINDOW RETENTION TEST PLOTS

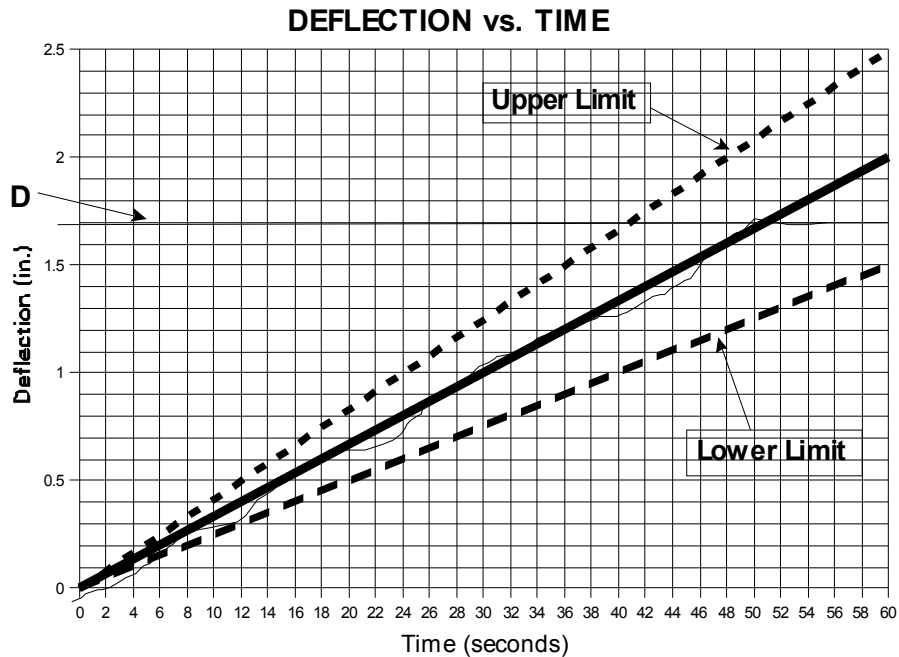

LOAD VS. DEFLECTION

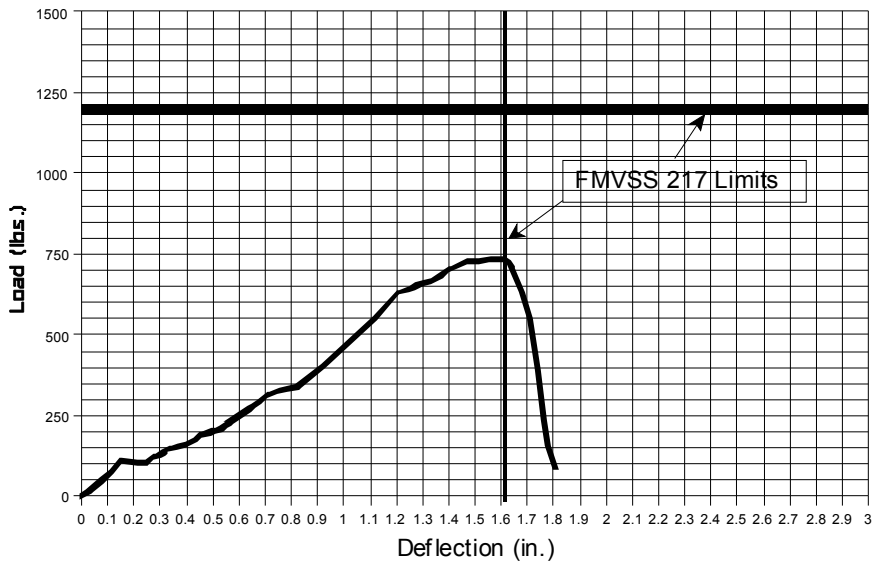

11. TEST DATA AND TEST VEHICLE DISPOSITION

The contractor shall make all vehicle preliminary compliance test data available to the COTR at the test site within 4 hours after the test. Final test data, including digital printouts and computer generated plots (if applicable), shall be furnished to the COTR according to the contract requirements. Additionally, the contractor shall analyze the preliminary test results as directed by the COTR. All backup data sheets, strip charts, recordings, plots, technician's notes, etc., shall be either sent to the COTR or destroyed at the conclusion of each delivery order, purchase order, etc.

11.1 TEST DATA LOSS

A compliance test is not to be conducted unless and until all the various test conditions specified in the OVSC laboratory test procedure have been met. Failure of a contractor to obtain the required test data and to maintain acceptable limits on test parameters in the manner outlined in the OVSC laboratory test procedure shall require a retest at the expense of the contractor. Retest costs will include the cost of the replacement vehicle and the service costs of conducting the retest. The original GFP will become the property of the contractor after the retest has been successfully conducted.

11.2 TESTED VEHICLE(S)

The contractor is responsible for providing necessary protection to the bus interior during storage following completion of testing (such as weather resistant protective coverings over open and/or broken windows or doors, etc.).

12. REPORTS

This section lists reports, other than final test reports, which the contractor shall submit to the COTR according to schedule. The following report forms are provided as examples. The contractor is not restricted from using other forms or expanding the forms outlined in this section as long as the content of the report remains unaltered.

12.1 MONTHLY STATUS REPORTS

The contractor shall submit a Monthly Test Status Report and a Vehicle Status Report to the COTR. The Vehicle Status Report shall be submitted until all vehicles or items of equipment are disposed of. Samples of the required Monthly Status Report forms are as follows.

12. REPORTS...Continued

MONTHLY TEST STATUS REPORT
 FMVSS 217
 DATE OF REPORT:

No.	BUS NHTSA No., MAKE & MODEL	COMPLIANCE TEST DATE	PASS/ FAIL	DATE REPORT SUBMITTED	DATE INVOICE SUBMITTED	INVOICE PAYMENT DATE
1						
2						
3						
4						
5						
6						
7						
8						
9						
10						

12.REPORTS....Continued

MONTHLY VEHICLE STATUS REPORT
FMVSS 217
DATE OF REPORT:

No.	BUS NHTSA No., MAKE & MODEL	DATE OF DELIVERY	ODOMETER READING	TEST COMPLETE DATE	BUS SHIPMENT DATE	ODOMETER READING
1						
2						
3						
4						
5						
6						
7						
8						
9						
10						

12. REPORTS...Continued**12.2 LABORATORY NOTICE OF TEST FAILURE REPORT**

Any indication of a test failure shall be communicated by telephone to the COTR within 24 hours, with written notification mailed within 48 hours (Sat./Sun. excluded). A Notice of Test Failure Report (see sample form below) with a copy of the particular compliance-test data sheet(s) and preliminary data plot(s) shall be included.

LABORATORY NOTICE OF TEST FAILURE TO OVSC

FMVSS NO.: 217 TEST DATE: _____

LABORATORY: _____

CONTRACT NO.: _____ DELV. ORDER NO.: _____

LABORATORY PROJECT ENGINEER'S NAME: _____

BUS DESCRIPTION: _____

NHTSA NO.: _____ VIN: _____

MFR: _____

TEST FAILURE DESCRIPTION: _____

S217 REQUIREMENT, PARAGRAPHS ____ : _____

NOTIFICATION TO NHTSA (COTR): _____

DATE: _____ BY: _____

REMARKS:

12. REPORTS...Continued

12.3 VEHICLE CONDITION REPORT

A form must be submitted to the COTR with the copies of the Final Test Report. The first page of the form shall be completed when the test vehicle arrives at the testing laboratory. The second page of the form is completed after the test. The forms shall be LEGIBLE (hand written forms are unacceptable) and COMPLETE (all information requested is filled out).

REPORT OF VEHICLE CONDITION (pg. 1)

CONTRACT NO. DTNH22-_____ Date: _____
 FROM: (Lab & rep name)
 TO: NHTSA, OVSC (NSA-31)
 PURPOSE: () Initial () Received () Present
 Receipt via Transfer vehicle condition
 MODEL YEAR/MAKE/MODEL/BODY STYLE: _____
 MANUFACTURE DATE: _____ NHTSA NO.: _____ BODY COLOR: _____
 VIN: _____ GVWR _____ GAWR (Fr) _____ GAWR (Rr) _____
 ODOMETER READINGS: ARRIVAL _____ miles DATE _____
 COMPLETION _____ miles DATE _____
 PURCHASE PRICE: \$ _____ DEALER'S NAME: _____

1. ALL OPTIONS LISTED ON A WINDOW STICKER ARE PRESENT ON THE TEST VEHICLE
2. TIRES AND WHEEL RIMS ARE NEW AND THE SAME AS LISTED
3. THERE ARE NO DENTS OR OTHER INTERIOR OR EXTERIOR FLAWS
4. THE VEHICLE HAS BEEN PROPERLY PREPARED AND IS IN RUNNING CONDITION
5. KEYLESS REMOTE IS AVAILABLE AND WORKING
6. THE GLOVE BOX CONTAINS AN OWNER'S MANUAL, WARRANTY DOCUMENT, CONSUMER INFORMATION, AND EXTRA SET OF KEYS
7. PROPER FUEL FILLER CAP IS SUPPLIED ON THE TEST VEHICLE
8. USING PERMANENT MARKER, IDENTIFY VEHICLE WITH NHTSA NUMBER AND FMVSS TEST TYPE(S) ON ROOF LINE ABOVE DRIVER DOOR OR FOR SCHOOL BUSES, PLACE A PLACARD WITH NHTSA NUMBER INSIDE THE WINDSHIELD AND TO THE EXTERIOR FRONT AND REAR SIDE OF BUS
9. PLACE VEHICLE IN STORAGE AREA
10. INSPECT THE VEHICLE'S INTERIOR AND EXTERIOR, INCLUDING ALL WINDOWS, SEATS, DOORS, ETC., TO CONFIRM THAT EACH SYSTEM IS COMPLETE AND FUNCTIONAL PER THE MANUFACTURER'S SPECIFICATIONS. ANY DAMAGE, MISADJUSTMENT, OR OTHER UNUSUAL CONDITION THAT COULD INFLUENCE THE TEST PROGRAM OR TEST RESULTS SHALL BE RECORDED. REPORT ANY ABNORMAL CONDITION TO THE NHTSA COTR BEFORE BEGINNING ANY TEST

12. REPORTS....Continued:

REPORT OF VEHICLE CONDITION AT THE COMPLETION OF TESTING (pg. 2)

LIST OF FMVSS TESTS PERFORMED BY THIS LAB:

VEHICLE _____ NHTSA NO.

REMARKS:

Equipment that is no longer on the test vehicle as noted on previous page:

Explanation for equipment removal:

Test Vehicle Condition:

RECORDED BY: _____ DATE:

APPROVED BY: _____ DATE:

#####

RELEASE OF TEST VEHICLE

The vehicle described above is released from _____ to be delivered to _____

Date: _____ Time: _____ Odometer:

Lab Representative: _____
Signature Title

Carrier/Customer Representative: _____
Signature Date

13. FINAL TEST REPORTS

13.1 REQUIREMENTS

The Final Test Report and associated documentation (including photographs) are relied upon as the chronicle of the compliance test. The Final Test Report will be released to the public domain after review and acceptance by the COTR. For these reasons, each final report must be a complete document capable of standing by itself.

The contractor should use DETAILED descriptions of all compliance-test events. Any events not directly associated with the standard but of technical interest should also be included. The contractor should include as much DETAIL as possible in the report.

Instructions for preparing the first three pages of the final test report are provided here for the purpose of standardization.

13.2 COPIES

In the case of a test failure, SEVEN copies of the Final Test Report shall be submitted to the COTR for acceptance within three weeks of test completion. Format of the Final Test Report to be used by all contractors can be found in the "Report Section."

Where there has been no indication of a test failure, THREE copies of each Final Test Report shall be submitted to the COTR within three weeks of test completion.

Payment of contractor's invoices for completed compliance tests may be withheld until the Final Test Report is accepted by the COTR. Contractors are requested to NOT submit invoices before the COTR is provided copies of the Final Test Report.

Contractors are required to submit the first Final Test Report in draft form within two weeks after the compliance test is conducted. The contractor and the COTR will then be able to discuss the details of both test conduct and report content early in the compliance-test program.

Contractors are required to PROOFREAD all Final Test Reports before submittal to the COTR. The OVSC will not act as a report quality-control office for contractors. Reports containing a significant number of errors will be returned to the contractor for correction, and a "hold" will be placed on invoice payment for the particular test.

13. FINAL TEST REPORTS....Continued

13.3 FIRST THREE PAGES

A. FRONT COVER

A heavy paperback cover (or transparency) shall be provided for protection of the final report. Information required on the cover is:

(1) Final Report Number (such as 217-ABC-0X-001), where :

217 is the FMVSS tested
 ABC are the initials for the laboratory
 0X is the fiscal year of the test program
 001 is the group number (001 for the 1st test,
 002 for the 2nd test, etc.)

(2) Final Report Title And Subtitle, such as -

SAFETY COMPLIANCE TESTING FOR FMVSS 217
 Bus Emergency Exits And Window Retention and Release

World Motors Corporation
 200X XYZ Transit Bus
 NHTSA No. CX0901

(3) Contractor's Name and Address (such as

COMPLIANCE TESTING LABORATORIES, INC.
 4335 West Dearborn Street
 Detroit, Michigan 48090

NOTE: DOT SYMBOL WILL BE PLACED BETWEEN ITEMS (3) AND (4)

(4) Date of Final Report completion

(5) The words "FINAL REPORT"

(6) The sponsoring agency's name and address, as follows:

U. S. DEPARTMENT OF TRANSPORTATION
 National Highway Traffic Safety Administration
 Enforcement
 Office of Vehicle Safety Compliance
 400 Seventh Street, SW
 Room 6111 (NVS-220)
 Washington, DC 20590

13. FINAL TEST REPORTS....Continued

B. FIRST PAGE AFTER FRONT COVER

A disclaimer statement and an acceptance signature block for the COTR shall be provided as follows:

This publication is distributed by the U.S. Department of Transportation, National Highway Traffic Safety Administration, in the interest of information exchange. The opinions, findings and conclusions expressed in this publication are those of the author(s) and not necessarily those of the Department of Transportation or the National Highway Traffic Safety Administration. The United States Government assumes no liability for its contents or use thereof. If trade or manufacturers' names or products are mentioned, it is only because they are considered essential to the object of the publication and should not be construed as an endorsement. The United States Government does not endorse products or manufacturers.

Prepared By: _____

Approved By: _____

Approval Date: _____

FINAL REPORT ACCEPTANCE BY OVSC:

Accepted By: _____

Acceptance Date: _____

13. FINAL TEST REPORTS....Continued**C. SECOND PAGE AFTER FRONT COVER**

A completed Technical Report Documentation Page (Form DOT F1700.7) shall be completed for those items that are applicable with the other spaces left blank. Sample data for the applicable block numbers of the title page follows.

Block 1 - REPORT NUMBER

217-ABC-0X-001

Block 2 ¥ GOVERNMENT ACCESSION NUMBER

Leave blank

Block 3 ¥ RECIPIENT'S CATALOG NUMBER

Leave blank

Block 4 ¥ TITLE AND SUBTITLE

Final Report of FMVSS 217 Compliance
Testing of 200X World XYZ Transit Bus
NHTSA No. CXXXXX

Block 5 ¥ REPORT DATE

March 1, 200X

Block 6 ¥ PERFORMING ORGANIZATION CODE

ABC

Block 7 ¥ AUTHOR(S)

John Smith, Project Manager
Bill Doe, Project Engineer

Block 8 ¥ PERFORMING ORGANIZATION REPORT NUMBER

ABC-DOT-XXX-001

13. FINAL TEST REPORTS....Continued

Block 9 ¥ PERFORMING ORGANIZATION NAME AND ADDRESS

ABC Laboratories
105 Main Street
Detroit, MI 48070

Block 10 ¥ WORK UNIT NUMBER

Leave blank

Block 11 ¥ CONTRACT OR GRANT NUMBER

DTNH22-0X-D-12345

Block 12 ¥ SPONSORING AGENCY NAME AND ADDRESS

United States Department of Transportation
National Highway Traffic Safety Administration
Enforcement
Office of Vehicle Safety Compliance
Mail Code: NVS-220
400 Seventh Street, SW, Room 6111
Washington, DC 20590

Block 13 ¥ TYPE OF REPORT AND PERIOD COVERED

Final Test Report
Feb. 15 to Mar. 15, 200X

Block 14 ¥ SPONSORING AGENCY CODE

NVS-220

Block 15 ¥ SUPPLEMENTARY NOTES

Leave blank

13. FINAL TEST REPORTS....Continued

Block 16 ¥ ABSTRACT

Compliance tests were conducted on the subject 200X World XYZ Transit Bus in accordance with the specifications of the Office of Vehicle Safety Compliance Test Procedure No. TP-217TB-0X for the determination of FMVSS 217 compliance. Test failures identified were as follows:

None

NOTE: Above wording must be shown with appropriate changes made for a particular compliance test. Any questions should be resolved with the COTR.

Block 17 ¥ KEY WORDS

Compliance Testing
Safety Engineering
FMVSS 217

Block 18 ¥ DISTRIBUTION STATEMENT

Copies of this report are available from:

NHTSA Technical Information Services (TIS)
Room 5108 (NPO-230)
400 Seventh St., SW
Washington, DC 20590
Telephone No. 202-366-4946

Block 19 ¥ SECURITY CLASSIFICATION OF REPORT

Unclassified

Block 20 ¥ SECURITY CLASSIFICATION OF PAGE

Unclassified

13. FINAL TEST REPORTS....Continued

Block 21 ¥ NUMBER OF PAGES

Add appropriate number

Block 22 ¥ PRICE

Leave blank

13.4 TABLE OF CONTENTS

Final test report Table of Contents shall include the following:

Section 1 ¥ Purpose of Compliance Test

Section 2 ¥ Test Data Summary

Section 3 ¥ Compliance Test Data

Section 4 ¥ Instrumentation and Equipment List

Section 5 ¥ Photographs

13. FINAL TEST REPORTS...Continued

A. Section 1 - PURPOSE OF COMPLIANCE TEST

This section briefly outlines the purpose for conducting the test and states the appropriate test procedure used. The following is provided as an example;

Tests were conducted on a 200X ABC, 80 passenger school bus, NHTSA No. CXXXXX, in accordance with the specifications of the Office of Vehicle Safety Compliance (OVSC) Test Procedure TP-217TB-XX to determine compliance to the requirements of Federal Motor Vehicle Safety Standards (FMVSS) 217 "Bus Emergency Exits and Window Retention and Release".

This program is sponsored by the National Highway Traffic Safety Administration (NHTSA), under contract No. DTNH22-XX-X-XXXXX.

NOTE: This section should be double-spaced and requires an entire separate page.

B. Section 2 - TEST DATA SUMMARY

This section gives a brief summary of the test results (see Data Sheet No. 1)

C. Section 3 - COMPLIANCE TEST DATA

This section requires the reporting of all information recorded on the following Data Sheets;

- (1) Data Sheet No. 2 - PROVISION OF EMERGENCY EXITS
- (2) Data Sheet No. 3 - EMERGENCY EXIT RELEASE
- (3) Data Sheet No. 4 - EMERGENCY EXIT OPENING
- (4) Data Sheet No. 5 - EMERGENCY EXIT IDENTIFICATION
- (5) Data Sheet No. 6 - WINDOW RETENTION TEST

13. FINAL TEST REPORTS....Continued

D. Section 4 - INSTRUMENTATION AND EQUIPMENT LIST

This section obtains a list of all the instrumentation and equipment used during the tests, including a description of the items, serial numbers and calibration dates. The following table is provided as an example.

EQUIPMENT AND INSTRUMENTATION LIST

EQUIPMENT	DESCRIPTION	SERIAL NO.	CAL. DATE	NEXT CAL. DATE
Ellipsoid	Minor Axis = 33 cm Major Axis = 50 cm	N/A	N/A	N/A
Force gauge	Model a1x1	454545	00/00/00	00/00/00
Displacement Transducer	Xr7 q	656565	00/00/00	00/00/00
ABC Load Cell	Model 1111	1234	00/00/00	00/00/00
Plotter #1	Model A	0202020	each use	
Plotter #2	Model B	0101010	each use	
XYZ Signal Conditioner	Model 2222	5678	00/00/00	00/00/00

E. Section 5 - PHOTOGRAPHS

This section obtains all photographs taken during the test as required by Section 8 - Photographic Documentation.

14. DATA SHEETS

Data Sheets are provided as tools to document test data in the Final Test Report format outlined in the previous section. The contractor is not restricted from using other tools or expanding the data sheets provided in this section. However, for consistency and uniformity in reporting data, the contractor shall format all final test reports in the order outlined in section 13 of this test procedure.

14. DATA SHEETS.....Continued

DATA SHEET No. 1 TEST DATA SUMMARY

A 37-passenger, 200X SuperBus1000 manufactured by ABC, Inc., (VIN:_____) was tested to the requirements of Federal Motor Vehicle Safety Standard No. 217, "Bus Emergency Exits and Window Retention and Release" on March 1, 200X. The bus was tested in accordance with the National Highway Traffic Safety Administration's test procedure TP-217TB-0X, dated March 1, 200X. The bus is equipped with two (2) emergency exit windows on the right and left sides of the bus and two (2) emergency roof exits located at the front and rear half of the bus. A summary of results is provided in the table below.

Table 1 - Test Data Summary

Section	Description	Pass/Fail	Reason
S5.2	Provision of Emergency Exits	Pass	
S5.3	Emergency Exit Release	Pass	
S5.4	Emergency Exit Opening	Pass	
S5.5	Emergency Exit Identification	Pass	
S5.1	Window Retention	Pass	

14. DATA SHEETS...Continued

DATA SHEET No. 2
PROVISION OF EMERGENCY EXITS
SCHEMATIC OF BUS FLOORPLAN

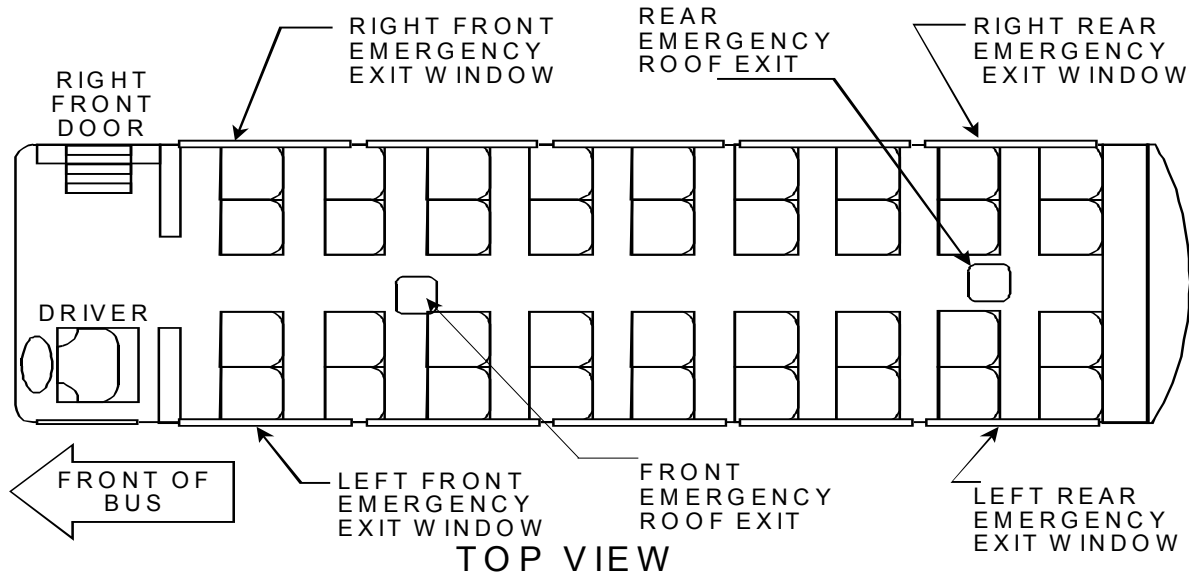

Table 2 - Provision of Emergency Exits

	Emergency Exit Type & Location	Size of Exit Opening (cm)	Actual Exit Area Measured (cm ²)	Maximum Credit Area Allowed (cm ²) (not to exceed 3,458)
1	Window, Right-Front	100 x 66	6,600	3,458
2	Window, Right-Rear	100 x 66	6,600	3,458
3	Roof, Rear	60 x 57	3,420	3,420
4	Roof, Front	60 x 57	3,420	3,420
5	Window, Left-Rear	100 x 66	6,600	3,458
6	Window, Left-Front	100 x 66	6,600	3,458
Total Credit Area				20,672

Total Required Area = 37 Designated Seating Positions (DSPs) X 432 cm² = 15,984 cm²
Total Credit Area = 20,672 cm² (PASS)

Each side of the bus must contain 40% of the Total Required Area
 (.40 X 15,984 cm²) = 6,394cm²

Total Credit Area-Left Side (2 windows) = (2 X 3,458 cm²) = 6,916 cm² (PASS)
 Total Credit Area-Right Side (2 windows)= (2 X 3,458 cm²) = 6,916 cm² (PASS)

14. DATA SHEETS...Continued

DATA SHEET No. 3

Table 3 - Access Regions and Forces Test to Release Exits

	Emergency Exit Type & Location	No. of Release Mechanisms	HIGH or LOW Access Region	Motions Required to Release Exit	Actual Motions to Release Exit	Peak Force Measured to Release Exit (N)		Max. Force Req'mnt. (N)	Pass	Fail
						1 st release mechanism	2 nd release mechanism			
1						1.				
						2.				
						3.				
						Avg. =				
2						1.				
						2.				
						3.				
						Avg. =				
3						1.				
						2.				
						3.				
						Avg. =				
4						1.				
						2.				
						3.				
						Avg. =				
5						1.				
						2.				
						3.				
						Avg. =				
						3.				
						Avg. =				

DATA SHEET No. 4

Table 4 - Access Regions and Forces Test to Open Exits

	Emergency Exit Type & Location	HIGH or LOW Access Region	Motions Required to Open Exit	Actual Motions to Open Exit	Direction of Motion differs 90°-180° from Release motion (Yes or No)	Peak Force Measured to Open Exit (N)	Max. Force Req'mnt. (N)	Pass	Fail
1						1.			
						2			
						3			
						Avg. =			
2						1.			
						2			
						3			
						Avg. =			
3						1.			
						2			
						3			
						. =			
4						1.			
						2			
						3			
						Avg. =			
5						1.			
						2			
						3			
						Avg. =			

14. DATA SHEETS....Continued

Data Sheet No. 5
Table 5 - Emergency Exit Identification

	Emergency Exit Type & Location	Description of Designation Label or Placard	Description of Operating Instructions Label or Placard	(For Buses w/ adjacent seats) Description of labels to indicate location of nearest release mechanism
1				
2				
3				
4				
5				

PASS FAIL

1. Each emergency exit has a permanently affixed, legible label or placard with the designation "Emergency Door" or "Emergency Exit"
2. Each emergency exit has a permanently affixed, legible label or placard describing the motion necessary to release (unlatch) and open the exit.
3. The label is within 16 cm of the nearest release mechanism.
4. For buses equipped with adjacent seats, a permanently affixed, legible label or placard has been placed with the occupant space to indicate the location of the nearest release mechanism.

14. DATA SHEETS...ContinuedData Sheet No.6
WINDOW RETENTION TEST

NHTSA NO.: _____ ; MAKE/MODEL:

1. Test Window Identification:
2. Provide a detailed description of the window such as fixed, push out, single or double glazed, horizontal or vertical sliding, etc.
4. Provide the horizontal and vertical glazing dimensions for each panel.
5. Did the window pass the retention requirements? Describe how the window structure and glazing withstood the force per the **PASS/FAIL** criteria:
6. Did the window pass the force tests to unlatch and open the exit after the completion of the retention test?

NOTE: MAKE A SEPARATE DATA SHEET FOR EACH WINDOW TESTED

REMARKS:

RECORDED BY: _____

DATE: _____

APPROVED BY: _____

APPENDIX