

Child Passenger Safety Restraint Systems on School Buses

National Training

Participant Manual

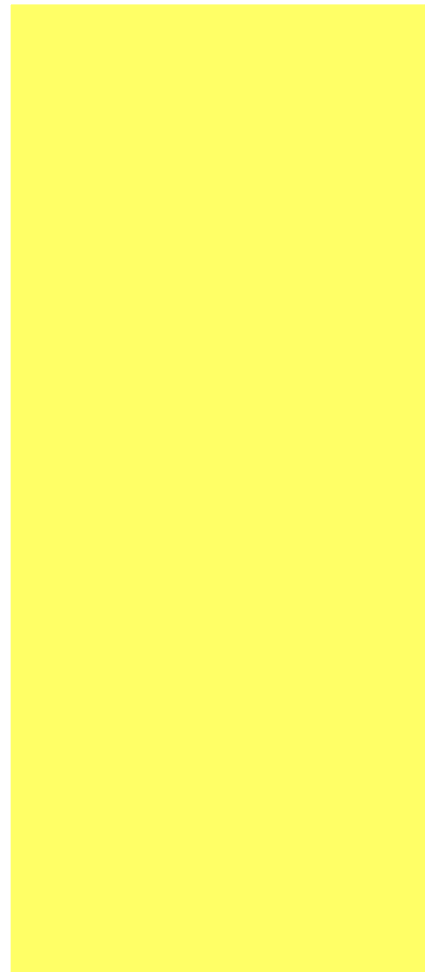
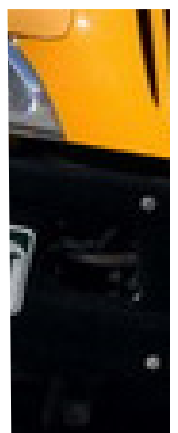
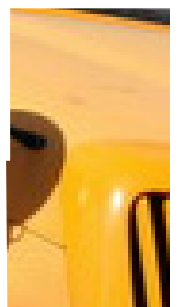

Table of Contents

Acknowledgements	iii
Chapter 1: Introduction	1
Chapter 2: Child Passenger Safety and the School Bus	17
Chapter 3: General Guidelines for Using CSRS	39
Chapter 4: Use and Installation of Conventional CSRS	63
Chapter 5: School Bus Specific CSRS, Safety Vests and Integrated Seats	75
Chapter 6: Proper Use of Lap/Shoulder Belts & Hands-On Installation	113
Chapter 7: Evacuation	129
Appendix	151
Guidelines for the Safe Transportation of Pre-school Age Children in School Buses.....	A 3
Federal Laws Guiding Special Education	A 7
Glossary of Terms.....	A 13
Quick Reference Guide to FMVSS and Regulations	A 19
FMVSS No. 213 Summary.....	A 25
LATCH Requirements.....	A 27
Web Sites for CPS	A 29
Cleaning and Maintenance	A 31
CSRS Safety Log.....	A 33
Reuse CSRS in School Bus After Minor Crash Guidelines	A 35
CSRS Registration Form	A 37
CSRS Questionnaire.....	A 39
AAP Technical Report.....	A 43

NASDPTS Sharing Student Health and Medical Information with School Transporters.....	A 61
AAP Transporting Children with Special Health Care Needs	A 69
Effective Restraints for Students with Special Needs	A 73
School Transportation Safety.....	A 79
Ride Safe Brochure.....	A 91
National Lap/Shoulder Belt Usage	A 97
Installation Signoff Sheet	A 99
103Z Vest Instructions	A 101
EZON Instructions 1086.....	A 103
EZON Instructions 543 KidCam.....	A 107
Over the Shoulder Information.....	A 111
BESI and Universal Securement Vest Instructions	A 113
Pro Tech Installation Instructions.....	A 115
HSM – CE White Child Safety Seat Instructions.....	A 117
HSM – CE White PCR	A 119
STAR Instruction Manual	A 121
SafeGuard Seat Instruction	A 127
Vendor Contacts	A 139

Acknowledgements

This National Highway Traffic Safety Administration revised curriculum is designed to be a comprehensive guide for those who wish to address the issues of transporting the pre-school population safely on school buses. In preparing this edition, we have carefully re-examined all of the content, clarified or updated much of the information from the previous edition and added a substantial amount of new information.

We are deeply grateful to the many Child Passenger Safety Technicians, Transportation Directors, School Bus Drivers/Monitors, Occupational Therapists, Physical Therapists, Early Intervention Specialists or other school personnel who contributed comments which helped us prepare *The Child Passenger Safety Training for School Buses National Training*.

We wish to recognize the contributions of the following people and companies. We apologize if we have neglected to acknowledge all of the people who in some way shared their knowledge or expertise with us.

Amy Artuso	E-Z-On Products
Riley Hospital's Automotive Safety Program	Safe Guard/IMMI
Linda Bluth	Syn-Tec Seating
Peggy Burns	Miriam Manary
Denise Donaldson	Charlie Vits
BESI, Inc.	Beth Warren
C.E. White/HSM	National Safety Council

A special thank you to Judith Talty for offering her guidance, extensive knowledge and precious time on this project

Thank you.

Sue Shutrump	Jennifer Booge
Cheryl Wolf	Charley Kennington
Roseann Schwaderer	

Thank you to Carla Aguiar who provided the technical assistance that was needed in completing this project by formatting into In-Design.

June 2015

Why are we here?

- ▶ School bus drivers are transporting young children.
- ▶ Pre-school age children and infants should be transported in Child Safety Restraint Systems (CSRS).
- ▶ School bus drivers are transporting children in Head Start.

Child Passenger Safety Restraint
Systems on School Buses

2

CLASSROOM NOTES:

- Although the focus of this course is on transportation of typically developing pre-schoolers, toddlers and infants, information regarding additional considerations for those children with special needs is also included. This is in recognition of the fact that some districts may transport younger children who have special needs or who attend “at risk” programs in compliance with federal mandates.
- More and more school bus drivers find themselves transporting pre-school age children and infants.
- All 50 states and the District of Columbia have child passenger restraint laws. National guidelines based on research recommend that pre-school age children be restrained in a CSRS during transport.
- This means that school bus drivers/attendants/monitors need to know about child safety restraints and how they work.
- The National Highway Traffic Safety Administration (NHTSA) has developed this course to meet that need.

Course Format

- ▶ 7 Chapters
- ▶ Lecture, activities, and hands-on practice
- ▶ Certificate of completion

Child Passenger Safety Restraint
Systems on School Buses

6

CLASSROOM NOTES:

In order to accomplish the objectives, the following topics will be covered:

- Introduction to the course
- School buses
- Seat belts
- Introduction to child safety restraint systems (CSRS)
- Rear-facing seats with practice installation
- Forward-facing seats with practice installation
- School bus specific CSRS, integrated school bus seats and lap/shoulder belts with practice installations
- Maintenance, disposal, and storage
- Emergency evacuation

The format will be a mixture of lecture and hands on activities:

- In order to be able to safely transport infants and pre-school age children on school buses you need to have hands-on experience with CSRS.

CLASSROOM NOTES:

School Bus Safety Facts

Safest form of land transportation:

- ▶ Larger and heavier
- ▶ Less likely to be in a crash
- ▶ Conspicuous
- ▶ Meets stringent FMVSS
- ▶ Occupant protection:
 - Compartmentalization
 - Seat Belts required on small buses



Child Passenger Safety Restraint Systems on School Buses

10

- School buses are the safest form of land transportation:
 - Larger and heavier
 - Less likely to be in a crash
 - Conspicuous
 - Meets stringent FMVSS
 - Occupant protection:
 - ▣ Compartmentalization
 - ▣ Seat belts required on small buses
- Compartmentalization is the primary form of occupant protection for school age children and was not designed for or proven effective for pre-school age children. Compartmentalization will be discussed in detail in the next chapter.

Resources for school bus safety facts:

- <http://www.nasdpts.org>
- <http://www.nhtsa.dot.gov>
- <http://americanschoolbuscouncil.org/>

CLASSROOM NOTES:

NHTSA Guidelines and State Laws

- ▶ NHTSA *Guideline for the Safe Transportation of Pre-school Age Children in School Buses*
 - The NHTSA Guidelines are based on NHTSA crash testing of pre-school age size dummies in school bus seats.
 - The test results showed that pre-school age children are safest when transported in CSRS.
- ▶ State laws
 - Governors Highway Safety Association link with state laws:
http://www.ghsa.org/html/stateinfo/laws/childsafety_laws.html

Child Passenger Safety Restraint
Systems on School Buses

11

- The NHTSA Guidelines are based on NHTSA crash testing of pre-school age size dummies in school bus seats. The test results showed that pre-school age children are safest when transported in CSRS.
- All states require that children age 4 and younger must be secured in a CSRS in passenger vehicles, they don't all extend the requirement to school buses.
- Even though a state law may not require a pre-school age child to be in a CSRS on a school bus, NHTSA guidelines recommend transport in a properly secured CSRS for all pre-school age children, which is considered best practice.

Head Start Regulations

- <http://cfr.regstoday.com/45cfr1310.aspx>
- Transport in allowable alternative vehicle in appropriate CSRS.
- Monitors are required on the school bus.



12

CLASSROOM NOTES:

Head Start regulations

- <http://cfr.regstoday.com/45cfr1310.aspx>
- Transport in allowable alternative vehicle in appropriate CSRS.
- Monitors are required on the school bus.

CLASSROOM NOTES:

Three Crashes in a Collision

- ▶ The Vehicle Crash
- ▶ The Human Crash
- ▶ The Internal Crash

Child Passenger Safety Restraint
Systems on School Buses

3

Every vehicle collision includes three crashes:

- **The Vehicle Crash:** The first stage involves the vehicle. A crash causes the vehicle to buckle and bend as it hits something and comes to an abrupt stop. This occurs in approximately 1/10 of a second in a front-end collision. The crushing of the front end absorbs some crash forces and cushions the rest of the vehicle. As a result, the passenger compartment comes to a more gradual stop than the front of the vehicle.
- **The Human Crash.** The second stage occurs as the vehicle stops. In a crash occupants move toward the point of impact, at the vehicle's original speed. Just after the vehicle comes to a complete stop, occupants collide with the steering wheel, windshield, seat belt, or some other part of the vehicle interior. This is the human crash.
 - **NOTE:** All objects in the vehicle move with the same speed upon impact whether secured or not. Another form of the human crash is the person-to-person impact:

- Unsecured occupants colliding with each other or an unsecured occupant colliding with a secured occupant can cause many serious or fatal injuries.
- **The Internal Crash.** The third stage occurs after an occupant's body comes to a complete stop. The internal organs are still moving forward until the organs hit something. Suddenly, organs hit other organs or the skeletal system. This third crash is the internal crash, often causing serious or fatal injuries.

CLASSROOM NOTES:

CLASSROOM NOTES:

Child Safety Restraint Systems

- ▶ Hold occupants in place.
- ▶ Spread crash forces over a wide area of the body, contacting the strongest body parts.
- ▶ Allow the body to “ride down” the crash forces.
- ▶ Protect head and spinal cord.

Child Passenger Safety Restraint
Systems on School Buses

4

Child Safety Restraint Systems:

- Hold occupants in place so that they are not thrown around and so that internal injuries are minimized or prevented.
- Spread the forces over a wide part of the body.
- Spread the forces over the strongest parts of the body.
 - For older children and adults, the strongest parts are the hips and shoulders.
 - For infants, there really isn't a strong part, so the rear-facing seat cradles the entire body and spreads the force over the entire back, head, and neck.
- Allow the body to slowly “ride down” the crash.
 - The belt and harness webbing stretch and the vehicle seat cushions compress to let occupants slow down more gradually than the vehicle.

- Protect the head and spinal cord.
 - The shoulder belt and the harness keep the head and upper body away from the hard surfaces of the vehicle.
- Improve postural control and helps assure student will sit upright and proper in the seat. This is especially important for some students with special needs.

CLASSROOM NOTES:

CLASSROOM NOTES:

Compartmentalization FMVSS 222

- ▶ Protective envelope with 2 features:
- ▶ Closely spaced seats
- ▶ Seat backs that are:
 - High
 - Flexible
 - Energy-absorbing

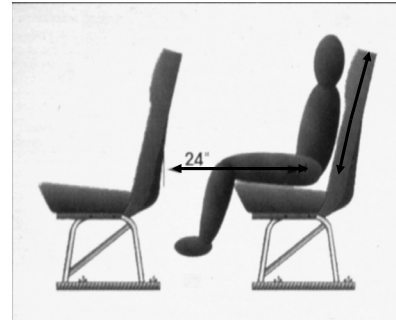

Child Passenger Safety Restraint Systems on School Buses

5

FMVSS 222 sets forth requirements for compartmentalization for large school buses.

Compartmentalization is a passive occupant protection system using the concept of eggs in a carton.

- A protective envelope is created that consists of:
 - Closely-spaced seats, maximum of 24 inches from the seating reference point (from the passenger hip to the seat back in front of the occupant).
 - To ease in the installation of CSRS it is strongly recommend the seats be spaced to the maximum spacing allowed under FMVSS 222.
 - High-backed seats (top of the seat is 24 inches from the seating reference point) that are flexible and padded on both sides to absorb energy.
- Only works when occupants are fully in the bus seat and facing forward.
 - It does not work when occupants are hanging in the aisles, or standing on the seat, etc.

CLASSROOM NOTES:

School Bus and CSRS

- ▶ To safely install a conventional CSRS a school bus must have:
 - Seat belt properly placed and attached or LATCH lower anchors.
 - Reinforced bus seat.

Child Passenger Safety Restraint
Systems on School Buses

8

To safely install a conventional CSRS a school bus must have:

- Seat belt properly placed and attached or LATCH lower anchors.
- Reinforced bus seat.

FMVSS 209

- ▶ If a school bus didn't come from the factory equipped with lap belts and now has lap belts, make sure that:
 - Lap belts are approved by the manufacturer for the specific seat it is to be installed on.
 - Lap belts were installed according to the manufacturer's instructions.
 - Retrofitted equipment is certified to meet FMVSS 209.



Child Passenger Safety Restraint
Systems on School Buses

9

CLASSROOM NOTES:

CLASSROOM NOTES:

Loops verses anchor attachments

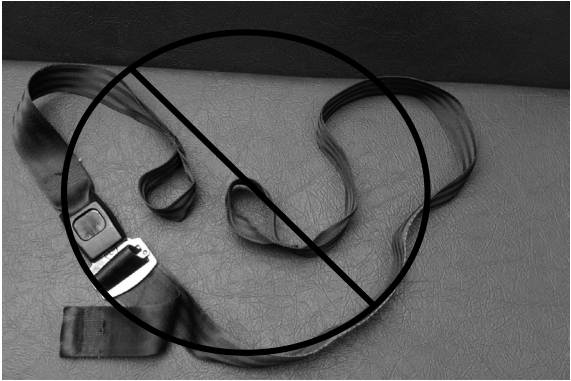

Child Passenger Safety Restraint
Systems on School Buses

10

FMVSS 209 gives the requirements for seat belt assemblies. This belt is unacceptable for installation of a CSRS on a school bus because it does not have anchor points meeting FMVSS 209.



CLASSROOM NOTES:

FMVSS 210 regulates what the seat belt is anchored to.

- In school buses, seat belts are anchored to the seat frame.
- This means that manufacturers must reinforce (strengthen) the seat frame that has a seat belt.
- Properly installed lap belts meeting Federal standards will not be looped, tied, or slip knotted to the school bus seat frame.

Note: Check with the manufacturer to confirm that the seat is compliant with FMVSS 210 and in addition make sure the type of belt you intend to use is compatible with the school bus seat.

CLASSROOM NOTES:

FMVSS 213

Provides performance standards

- ▶ CSRS up to 80 pounds
- ▶ Crashworthiness
- ▶ Flammability
- ▶ Buckle release pressure
- ▶ Crotch Strap/Support

Child Passenger Safety Restraint
Systems on School Buses

12

FMVSS 213 provides CSRS performance standards for children up to 80 pounds.

- Some of these standards include:
 - Crashworthiness (how a CSRS holds up in a crash)
 - Labeling and instructions
 - Manufacturer's identification
 - That it meets FMVSS 213 requirements
 - Model number and date
 - Basic instructions
 - Size limits
 - Flammability
 - Buckle release pressure
- CSRS manufacturers self-certify their equipment.
- NHTSA randomly tests CSRS on a vehicle bench seat in a 30 mph (20G) frontal crash involving crash test dummies.

FMVSS 225

› Also known as LATCH –

Lower
Anchors and
Tethers
for **CH**ildren

Child Passenger Safety Restraint
Systems on School Buses

13

CLASSROOM NOTES:

FMVSS 225 sets the standard for LATCH in vehicles. LATCH stands for Lower Anchors and Tethers for Children. It is an alternative way of installing child safety seats without having to use vehicle seat belts. Child safety seats with LATCH are equipped with flexible or rigid anchors that attach to rigid anchors in the vehicle. The rigid vehicle anchors are located at the junction of the vehicle seat back and bottom.

Remember, two lower connectors should never be attached to one lower anchor.

- NEVER install a CSRS using lower anchors and the seat belt at the same time unless specifically allowed by both the seat and vehicle manufacturers. It should be one system or the other because that is how the CSRS was crash tested.

LATCH in vehicle has two parts:

- Lower anchorages in or near seat bight (the base/crack of the seat).
 - Required in two seating positions in a small school bus (10,000 pounds or less).
 - Optional on a large school bus.

CLASSROOM NOTES:

Multi Function School Activity Bus (MFSAB)



Child Passenger Safety Restraint Systems on School Buses

15

The MFSAB is classified as a school bus.

- The MFSAB must meet all federal standards for a school bus other than the traffic control devices.
- There is no upper weight limit on the MFSAB.
- The MFSAB must meet all warning label requirements applicable to school buses. There is no label unique to the MFSAB.
- Because school bus color is regulated by state law, NHTSA does not prohibit the MFSAB from being painted National School Bus Glossy Yellow.
- This vehicle would qualify as an “**Allowable Alternative Vehicle**” defined in Head Start Regulations.

Since the MFSAB would not pick up or drop off students, on the street, there is no need for traffic control devices such as the 4-way/8-way alternating flashing lights and stop arms.

Questions?

Child Passenger Safety Restraint
Systems on School Buses

16

CLASSROOM NOTES:

CLASSROOM NOTES:

Lined area for taking classroom notes.

Location

- ▶ Best practice is CSRS should be placed in the front of a school bus if possible.
- ▶ Never place CSRS in front of an emergency exit.
- ▶ Place CSRS next to window if another child is going to sit beside him/her.
- ▶ Adequate room between bus seats.
- ▶ Adequate aisle width.

Child Passenger Safety Restraint
Systems on School Buses

6

CLASSROOM NOTES:

- Although there may be many seating positions on a bus, best practice is to place the CSRS in the front of the bus unless the child has special circumstances requiring alternative placement. Never place a CSRS next to an emergency exit and place the CSRS next to the window if the bus seat must accommodate more than one child.
- It is recommended that when writing specifications for a school bus intended to be used to transport pre-school aged passengers
 - Order the maximum spacing allowed under FMVSS 222.
 - Consider ordering a 39 inch seat on one side and a 30 inch seat on the other side of the bus to maximize the aisle width.

Installation Basics

- ▶ Correct belt path.
- ▶ Recline according to manufacturer instructions.
- ▶ Tight and locked in place when checked at the belt path.
 - Should not move more than one inch.
 - Using seat belt or lower anchors.
 - **(Do not use both)**



Child Passenger Safety Restraint
Systems on School Buses

8

CLASSROOM NOTES:

- Read the CSRS manufacturer's instructions for specific information on installation.
- Look on the CSRS for belt path arrow or label.
- Place the CSRS on the bus seat in the proper direction and at the correct recline angle.
- Carefully thread the seat belt or lower connectors through the correct belt path as directed by the manufacturer. Be careful not to have any twists.
- Buckle and lock the seat belt or connect the lower connectors to the anchors in the vehicle.
- Press down firmly on the base or CSRS and tighten. The base or CSRS should NOT move side-to-side or front-to-back more than 1 inch when tested at the belt path.
- Check the following to see if the CSRS fits on the bus seat.
 - Make sure there is enough space for the CSRS to allow for the correct angle.
 - Make sure at least 80 percent of the CSRS base (footprint) fits on the vehicle seat. Some models require that 100 percent of the footprint fit on the vehicle seat.

CLASSROOM NOTES:

Correct Lap Belt Length for Installation of Conventional CSRS

- Non-adjustable end (buckle) of lap belt extends no more than 1-2 inches.
- Starting in October 2011 all buses with lap belts are required to be manufactured to extend no longer than 1 to 2 inches out of the seat bight.



- The bight of the seat is where the seat back and seat bottom meet.
- Many seat belts on school buses manufactured prior to October 2011 have excess webbing on the non-adjustable end. If the webbing on the buckle is too long, the buckle may rest on the frame of the CSRS. In this position, the lap belt can't be secured tightly and may loosen as the school bus is driven.
- The solution would be to replace the lap belt with one of the appropriate webbing length: 1-2 inches out of the seat bight.

CLASSROOM NOTES:

Securing the Child in a CSRS

- ▶ Place the child in the CSRS with back and bottom flat against the seat.
- ▶ Put harness straps over shoulders and buckle at the crotch.
- ▶ Harness straps at or below the shoulders for rear-facing seats.
- ▶ Harness straps at or above the shoulders for forward-facing.
- ▶ Harness snug (pinch test).
- ▶ Harness retainer clip at the armpit level.
- ▶ Crotch strap positioned close to the body.

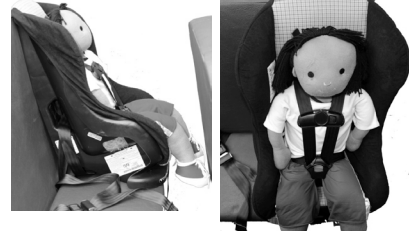

Child Passenger Safety Restraint
Systems on School Buses

11

- Place the child all the way back in the CSRS.
- Place the harness straps at or below the child's shoulders for rear-facing and at or above for forward-facing, according to manufacturer instructions, and buckle at the crotch.
- Pull the slack out of the hip straps before pulling the shoulder straps and harness snug.
- Tighten harness straps snugly.
 - NHTSA requires CSRS manufacturers to state in the instructions: **"A snug strap should NOT allow any slack. It lies in a relatively straight line without sagging. It does not press on the child's flesh or push the child's body into an unnatural position."**
 - You should **NOT** be able to pinch excess webbing at the shoulder or hips once the harness is buckled. This is called the pinch test.
- Place the harness retainer clip at armpit level.
- Only place blankets around the child after the harness is snug and secure. Unapproved padding

CLASSROOM NOTES:

Considerations for Pre-schoolers with Special Needs

- ▶ Whenever possible use conventional seats/ CSRS if they will meet the child's needs.
- ▶ Less expensive than the special needs seats.
- ▶ Commercially available.



Child Passenger Safety Restraint Systems on School Buses

12

- In some ways, the approach for selecting the best restraint for a child with special needs is the same as for any child. The seat should be appropriate for the child's weight, height, physical development and behavioral needs.
- First option is to use a conventional CSRS if it meets the child's needs:
 - Easier to find
 - Less expensive
- Manufacturer's instructions should be read and followed carefully.

Considerations for Pre-school age Children with Special Needs

- Special needs CSRS may be necessary.
- These seats may have higher weight limits and features for positioning support.



22-105 pounds and 56 inches or less



22-102 pounds and 36-60 inches



25-130 pounds and 66 inches or less

Child Passenger Safety Restraint
Systems on School Buses

13

CLASSROOM NOTES:

- Sometimes a specially adapted CSRS is needed when a conventional CSRS does not meet all needs.
- In some cases a special needs CSRS may be prescribed by a therapist and approved by a physician and may need to be ordered from a medical supply company.
- All or part of the CSRS may be paid for by the child's health insurance. If a child does not have a special needs seat but may require one for the maximum protection while riding on a school bus then the school district may have to purchase the seat in order to be in compliance with the laws that govern special needs transportation.
- These seats may have higher weight limits for the internal harness or other special features to provide positioning support (e.g. ability to recline further in a forward-facing position). Additional head or trunk control may be the reason to select one of these seats.

CLASSROOM NOTES:

Tethering Special Seats

- ▶ Follow the manufacturer instructions regarding how to tether special seats.

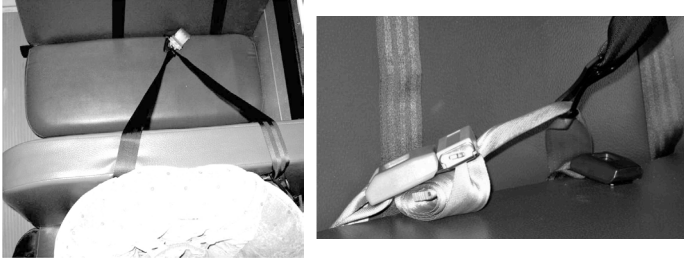

Child Passenger Safety Restraint
Systems on School Buses

14

- Special needs CSRS must be tethered.
- If tether anchors are not available on a school bus or don't accommodate the child's weight, some special needs seats may be able to be tethered to a seat belt in the row behind it.
- Check with the manufacturers of the bus seat and the special CSRS to make sure this is allowed.

CLASSROOM NOTES:

Consumer Information – Reporting Defects

- ▶ Transporter reports the problem
- ▶ Where to report it:
 - Manufacturers
 - <https://www-odi.nhtsa.dot.gov/ivoq/>
 - DOT Auto Safety Hotline 1-888-DASH-2-DOT
- ▶ Current recall list
 - www-odi.nhtsa.dot.gov/cars/problems/recalls/childseat.cfm

Child Passenger Safety Restraint
Systems on School Buses

15

- Each CSRS comes with a product registration form that should be completed and mailed back to the manufacturer.
- Manufacturers can then let product owners know if there is a recall.
- If the child safety seat registration form has not been sent in initially, it can be submitted using the NHTSA CSRS registration form, provided in the Appendix, or a registration form can be submitted online through the manufacturer's web site.
- Not all recalls directly affect performance. For example, an error printed in the Spanish instructions would not concern those reading instructions in English.
- Some recalls do not impact crash performance. For example, a defect reported about a carrying handle will not affect the CSRS during a crash.
- All instructions provided by the manufacturer must be followed.

Chapter Objectives

- ▶ Explain why children should travel facing the rear of vehicle.
- ▶ Explain how to use and install rear-facing and forward-facing CSRS.



2

CLASSROOM NOTES:

CLASSROOM NOTES:

Why Children Should Travel Rear-Facing

- ▶ Physical development
 - Babies have big heads.
 - Bones, tendons, and muscles are not fully developed.

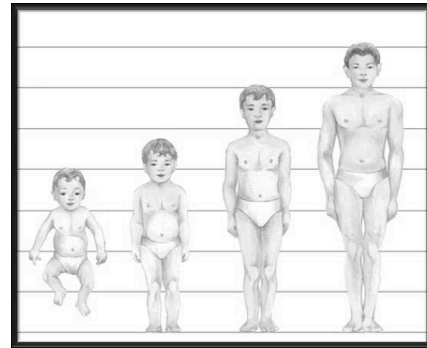

Child Passenger Safety Restraints
on School Buses

3

- This slide shows how a child's body changes as the child grows. Different types of CSRS are made to support the child's growth.
- The infant's head is larger and heavier in proportion to its body than that of an older child. In a frontal crash if the child is facing forward their head will move abruptly forward placing increased forces on the neck. But when a child is properly restrained rear-facing the head moves with the seat reducing the risk for a neck and spine injury.
- Rear-facing only seats are engineered to distribute the forces of a crash across the entire head and body of an infant and young child. The harnesses are attached snugly to keep the child from sliding up the back of the seat and from flying out of the seat in a crash.
- In a frontal crash, the rear-facing CSRS cradles and moves with the child. It is the shell of a CSRS itself that absorbs the forces.

How Long Should Children Travel Rear-Facing?

- ▶ All infants and toddlers should ride in a rear-facing CSRS until they are two years of age or until they reach the highest weight or height allowed by the manufacturer of their CSRS.

Source: AAP

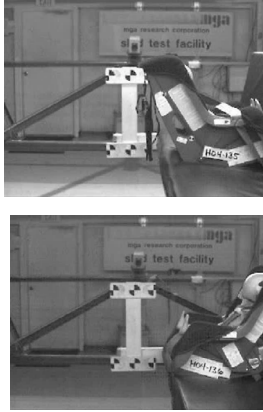

Child Passenger Safety Restraints on School Buses

4

CLASSROOM NOTES:

- Rear-facing only until the child is 2 years of age or
 - Until the child reaches the highest weight or height limit allowed by the rear-facing restraint.
- Students with special needs who have poor head or trunk control may benefit from being transported rear-facing longer providing that they do not exceed the height and weight limits of the CSRS.

CLASSROOM NOTES:

Rear-Facing Only CSRS

- ▶ Head should be 1 inch below the top of the shell.
- ▶ Recline according to manufacturer's instructions.
- ▶ Use harness straps at or below shoulder level.
- ▶ Refer to manufacturer's instruction for proper handle position during transport.
- ▶ Many rear-facing only restraints come with a detachable base.
 - Some models require using the base at all times.



Child Passenger Safety Restraints
on School Buses

5

- Check labels on rear-facing only CSRS for the minimum weight allowed. Most give a specific weight (4 or 5 pounds), while a few say “from birth”.
- The top of the child's head should be well contained within the shell (unless the manufacturer's instructions state otherwise) and not less than 1 inch from top of shell.
- The harness needs to be snug to the child down low in the CSRS so he/she does not slide up and out of the CSRS in a crash.

CLASSROOM NOTES:

Rear-Facing Convertible CSRS

- ▶ Use when babies outgrow rear-facing only CSRS.
- ▶ Use rear-facing position to the highest weight/height allowed by the CSRS manufacturer's instructions.
- ▶ Recline according to manufacturer's instructions.
- ▶ Use rear-facing belt path.
- ▶ Use harness slots at or below shoulder level.



Child Passenger Safety Restraints
on School Buses

6

- Many new convertible CSRS are approved for rear-facing use to 35 pounds and beyond. Convertible seats should be considered for infants who have outgrown their rear-facing only seat.
- Always check the CSRS manufacturer's instructions for upper and lower weight/ height limits.

CLASSROOM NOTES:

Installation – Angle

- ▶ The CSRS must be installed at an angle specified in the CSRS instructions (usually placing the child's back 30 to 45 degrees from upright).
- ▶ The proper angle keeps the CSRS upright enough to spread forces across the child's back, not the shoulders.
- ▶ It also reclines enough to keep the child's head back and the airway open.

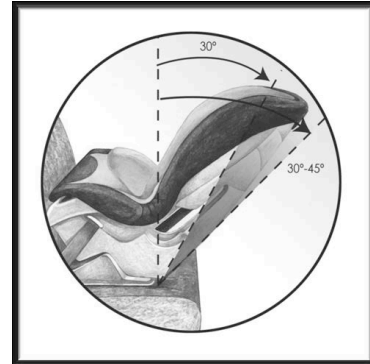

Child Passenger Safety Restraints
on School Buses

7

- Correct recline angle:
 - Follow CSRS manufacturer's instruction for acceptable rear-facing recline angle.
 - Not all manufacturers recommend the same angle.
- CSRS recline indicator:
 - The recline-angle indicator is part of the CSRS and should be used as indicated by the manufacturer.
 - Many rear-facing only CSRS have a detachable base with an adjustable foot that is used to correct the angle.
 - For CSRS that do not have an adjustable base, a firm lightweight object (i.e., a tightly rolled towel or pool noodle) can be placed at the vehicle seat crack or bight.

CLASSROOM NOTES:

Forward-Facing Convertible CSRS

- ▶ A convertible CSRS can be “converted” from rear-facing to forward-facing.
- ▶ Read the owner's manual to ensure the seat is converted correctly.
 - Use forward-facing belt path
 - Use forward-facing harness slots
- ▶ Typically manufacturer instructions recommend they be in the upright position when used forward-facing.
- ▶ Some manufacturers allow a semi-reclined position as well as fully upright. Consider this position if the child has special needs.
- ▶ Some harness systems are approved for use to 40 pounds and some are approved for higher weights.

Child Passenger Safety Restraints
on School Buses

9

- Forward-facing convertible CSRS can be “converted” from a rear-facing to a forward-facing CSRS.
- Always check the CSRS manufacturer's instructions for information on converting the CSRS from rear-facing to forward-facing.
- Forward-facing CSRS should be used when children have outgrown their rear-facing CSRS.
- Forward-facing CSRS should be used to the highest weight/height allowed by the manufacturer.
- Use the harness straps at or above shoulder level.
- Many CSRS are installed upright when forward-facing.
- A child's ears should not be above top of the shell.
- Make sure to use the forward-facing belt path

CLASSROOM NOTES:

Combination CSRS

- ▶ Use to the highest harness weight/height allowed by manufacturer.
- ▶ Use harness straps at or above shoulder level.
- ▶ Typically they are installed upright.
- ▶ Child's ears should not be above top of shell.
- ▶ Cannot be used on a school bus as a booster.



Child Passenger Safety Restraints
on School Buses

10

- Combination CSRS should be used to the highest harness weight/height allowed by the manufacturer.
 - Make sure the upper weight limit for the harness is not confused with the upper weight limit of the CSRS used as a booster.
- Use the harness straps at or above shoulder level.
- A child's ears should not be above top of the shell.

CLASSROOM NOTES:

School Bus Specific CSRS

- Compared to a conventional CSRS
 - All forward-facing systems seat child fully upright (must be at least 25 lbs).
 - Accommodates broader range/larger students.
 - Often allows for increased occupancy.
 - May better accommodate children with medical braces or casts.

Child Passenger Safety Restraint
Systems on School Buses

3

- Available school bus specific CSRS are not appropriate for infants or those students who need recline or head support.
- They accommodate larger children.
- They can assist in meeting the requirements of transportation in the Least Restrictive Environment (LRE).
- Most manufacturers of school bus specific CSRS recommend that a child weigh at least 25 pounds before using their system.

School Bus Specific Add-On CSRS and Safety Vests

- ▶ Five point harness systems.
- ▶ Attached to bus seat through use of cam wrap.
- ▶ Do not utilize lap belts.
- ▶ Can be used on traditional (non-210) and reinforced 210 compliant bus seats.
- ▶ Meet FMVSS 213 including required crotch strap/support.



Child Passenger Safety Restraint
Systems on School Buses

4

CLASSROOM NOTES:

- Can be used on traditional (non-210) and reinforced 210 compliant bus seats.
 - Check state law as some states may require reinforced 210 seats when using a safety vest.
- Must be compliant with FMVSS 213 including crotch strap/support.

CLASSROOM NOTES:

School Bus Specific Lap Belt Add-On CSRS

- Five point (with lap belt) harness systems.
- Attached to bus seat through use of cam wrap or portable seat mount technology.
- Utilize lap belts.
- Must be used on reinforced 210 compliant bus seat.
- Meet FMVSS 213 including required crotch strap/support.

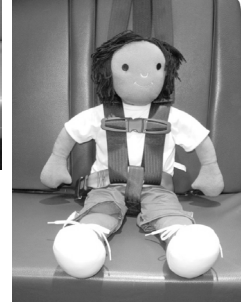

Child Passenger Safety Restraint Systems on School Buses

Lap belt, cam wrap/portable seat mount and crotch strap are all utilized.

All Systems Utilizing Cam Wrap Technology

- Entire seat directly behind must be unoccupied or have restrained occupants when cam wrap attached CSRS is occupied.
 - Restrained means use of any restraint.
 - Lap belt, lap/shoulder belt, or CSRS.
- Protects the occupant in the CSRS that's installed by a cam wrap from the effects of double loading.

Child Passenger Safety Restraint
Systems on School Buses

6

CLASSROOM NOTES:

CLASSROOM NOTES:

School Bus Specific Add-On CSRS Installation

- Seat Mount:
 - Attaches CSRS to bus seat back
 - Attaches CSRS to bus seat bottom
- Sequence of Strap Installation Differs By Product



Child Passenger Safety Restraint
Systems on School Buses

7

- Guideline specifics are included in manufacturer's instructions and must be followed closely.
- Manufacturer's guidelines should be available for review by transportation staff.

CLASSROOM NOTES:

Add-On CSRS Installation Attaching to Bus Seat Bottom

- ▶ Ensure that seat bottom or pad is fully seated into the seat bight.
- ▶ Ensure straps are not twisted and correctly routed.
- ▶ Hold seat bottom or pad in place when tightening strap system.
- ▶ Ensure strap system is secured to prevent slippage on bus seat.



Child Passenger Safety Restraint
Systems on School Buses

9

- Consult manufacturer for instructions of belt path on bus seats if in doubt.
- Belt path is not a suggestion; it is an absolute specification that the manufacturer has determined and tested to assure compliance with FMVSS 213.

Proper Fit/Use of Add-On CSRS

- Start with harness/strap system adjusted to its full length position to allow for less intrusion into child's personal space.
- Seat child fully in system with their back and bottom against seat back.



Child Passenger Safety Restraint
Systems on School Buses

10

CLASSROOM NOTES:

Following the strategies described in the slide that respect the child's personal space builds trust and rapport between families, students and transportation/school staff.

CLASSROOM NOTES:

Securing Child in Add-On CSRS

- ▶ Position harness shoulder straps on child ensuring that straps are attached to the CSRS as close to the top of the shoulders as possible but not below the child's shoulders.

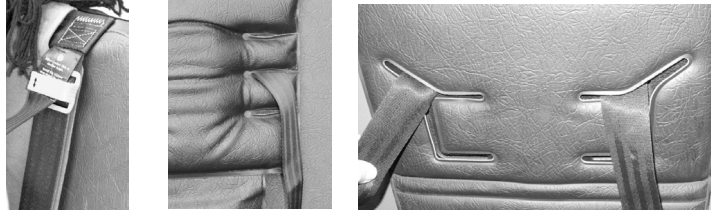

Child Passenger Safety Restraint
Systems on School Buses

11

- As a forward-facing system, shoulder straps must thread/anchor into the CSRS **at or above** the shoulders. Placement should be as close to the shoulders as possible.
- Students may grow out of the Add-On CSRS due to increased torso height before exceeding the height and weight limits of the CSRS.

Securing Child in Add-On CSRS

- ▶ Holding the buckle as far away from the child as possible with the back of the hand positioned towards their body, insert/ fasten strap latch plates into buckle.
- ▶ Snug harness, fasten and position harness clip, check with pinch test.



Child Passenger Safety Restraint Systems on School Buses

12

CLASSROOM NOTES:

Following strategies that respect the child's personal space builds trust and rapport between families, students and transportation/school staff.

Securing the Passenger in School Bus Specific Lap Belt Add-On CSRS

- ▶ Position the child on the bus seat with the crotch strap(s) between their legs.
- ▶ Place harness straps over the student's shoulders.
- ▶ Thread lap belt through harness and crotch straps per manufacturer's instructions.
- ▶ Adjust harness and crotch straps ensuring that lap belt stays low on pelvis with lower edge of belt on thigh of child.



Child Passenger Safety Restraint
Systems on School Buses

16

CLASSROOM NOTES:

- It is important that properly adjusted harness and crotch straps ensure that the lap belt remains low on the pelvis of the child with the lower edge of the belt touching the child's thighs.
- The crotch strap must be adjusted to keep the belt properly positioned throughout transport.

Fit Of Two-Part Safety Vest Best Done By Trained School Staff/Families

- Reduces load/unload time.
- Done by people who know student best.
- Can be put on under bulky outer wear with buckles/mount attachment sites exposed.

Child Passenger Safety Restraint
Systems on School Buses

18

CLASSROOM NOTES:

CLASSROOM NOTES:

Purchase with Adjustability Options to Meet Varied Needs

- ▶ Adjustable Shoulder Straps
- ▶ Zipper Inserts
- ▶ Adjustable Seat Mount



Child Passenger Safety Restraint
Systems on School Buses

19

- Preplanning for use with multiple children should be done before purchase of inventory.
- To ensure a proper fit daily
 - Account for seasonal clothing changes.
 - Mark seats to ensure proper fit of seat mount if removed or used for more than one student.
 - Check all installations daily on pre-trip inspections.
 - Locking bar slides is especially important.

Locking at Fixed Length Adjustable Shoulder Straps On Seat Mount and Safety Vests

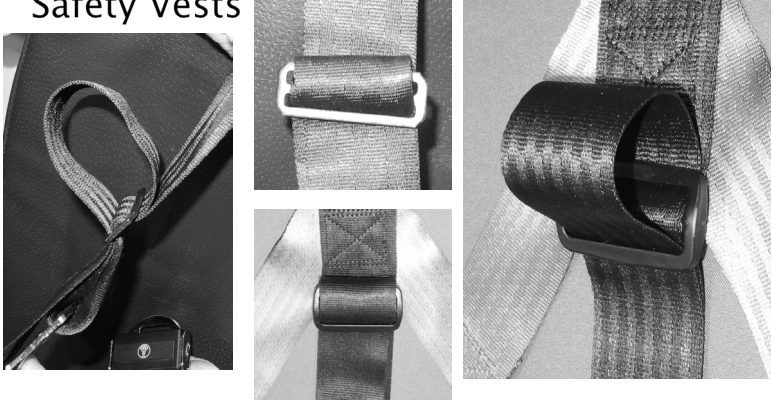

Child Passenger Safety Restraint
Systems on School Buses

20

CLASSROOM NOTES:

With the foam in bus seats coupled with the increased bouncing/movement on the bus, unlocked adjustable straps quickly revert to a loose fit.

Procedural Safeguards for Use of CSRS With Students With Behavioral Issues

- ▶ Assure less restrictive supports have been tried and found ineffective.
- ▶ Stress that it meets FMVSS 213 as do all child safety seats/CSRS.
- ▶ Safety Vest not "Harness".
- ▶ Do not modify: Use only per strict manufacturer's guidelines.
- ▶ Assure plan is in place to support student learning proper behavior to eliminate need for alternate CSRS (safety vest).
- ▶ Specify plan in Individual Transportation Plan (ITP).
- ▶ Document full team involvement and implementation.

Child Passenger Safety Restraint
Systems on School Buses

22

CLASSROOM NOTES:

The requirement of providing service in the least restrictive environment (LRE) dictates that less restrictive supports have been tried and found ineffective. Some of these may include:

- Visual supports/schedules
- Fidgets/activities/busy bag
- Alternate/multi-sensory modes utilized to communicate bus safety rules and expectations
- Source of triggers analyzed and accommodated
- Behavior intervention plans/reinforcements

Proper Fit of Safety Vest

- The child's waist measurement determines the appropriate size of the vest. However, there are some weight restrictions associated with each vest size.
- Position child's arms through shoulder straps adjusting length to ensure lower horizontal strap is positioned low on pelvis.



Child Passenger Safety Restraint
Systems on School Buses

24

CLASSROOM NOTES:

- Weight and size restrictions vary by manufacturer.
- It is important to consult all manufacturers' instructions for specific guidelines/ recommendations.

Proper Fit of Safety Vest

- ▶ Holding the ends of crotch straps, bring them through the child's legs and fasten buckles.
- ▶ Adjust to fit comfortably but to prevent the child from sliding under the vest.
- ▶ Re-thread all adjustable straps to lock in place.

Child Passenger Safety Restraint
Systems on School Buses

26

CLASSROOM NOTES:

- Following strategies that respect the child's personal space builds trust and rapport between families, students and transportation/school staff.
- The foam in bus seats coupled with the increased bouncing/movement on the bus will quickly cause unlocked adjustable straps to revert to a loose fit.
- Daily check of fit is the responsibility of transportation staff even when parents/school staff are responsible for putting on and taking off the safety vest.
- School staff and/or families must be appropriately trained to put on and take off the safety vest.

CLASSROOM NOTES:

Safety Vest Cam Wrap or Seat Mount Installation

- ▶ **Seat Mount:**
 - Wraps around bus seat back.
 - Positions attachment hardware at hips and shoulders.
- ▶ **Orienting Mount for installation**
 - Adjustable straps at shoulders.
 - Fixed straps at hips.
 - Buckle release button faces the seat back.



Child Passenger Safety Restraint Systems on School Buses

27

- Orientation specifics should be reviewed in manufacturer's literature/guidelines.
- The route path of the straps can differ by manufacturer. Consult manufacturer's instructions.
- The bus seat cushion should not be locked onto the frame until the length of the hip straps is correct.

First: Refine Fit of Hip Straps of Safety Vest Cam Wrap or Seat Mount

- ▶ Seat child fully upright on bus seat with bottom against seat bight and shoulders and back against seat back.
- ▶ Ensure vest is worn low on the child with the bottom edge of hip strap webbing touching the child's upper thighs.
- ▶ Connect hip strap buckle/ fastener to vest anchor point/ring being certain that it secures hips firmly against seat back.



Child Passenger Safety Restraint Systems on School Buses

28

CLASSROOM NOTES:

The hips must be secured firmly against the seat back for proper installation.

Adjusting Shoulder Straps of Safety Vest Cam Wrap/Seat Mount

- ▶ Adjust shoulder straps so that they keep shoulders snug against seat back with buttocks firmly seated on the bus seat.
- ▶ Check fit by asking child to bend forward towards target.
- ▶ When correct fit is achieved, lock adjustable belts by re-threading loose ends.
- ▶ Fit of entire cam wrap/seat mount should be checked daily.



Child Passenger Safety Restraint
Systems on School Buses

30

CLASSROOM NOTES:

- The foam in bus seats coupled with the increased bouncing/movement on the bus will quickly cause unlocked adjustable straps to revert to a loose fit.
- Daily check of fit is the responsibility of transportation staff despite who is responsible for installing the cam wrap/seat mount.

CLASSROOM NOTES:

Integrated Seat

- ▶ Forward-facing CSRS with a 5-point harness built into the bus seat.
- ▶ Easy shoulder height adjustment.
- ▶ Varying size restrictions.
- ▶ Procedures for the harness systems are the same as outlined previously.
- ▶ Maintain harnesses to ensure the straps remain flat to prevent twisting and folding.
- ▶ Don't forget to train!



Child Passenger Safety Restraint
Systems on School Buses

31

- For children who have difficulty sitting with their legs out straight, you can place a towel roll under their knees.
- Follow seat manufacturer's directions for set-up of child seat. Fold seat cushion under itself if manufacturer requires it be done for usage.
- The panel should stay closed when the CSRS is not in use to avoid damage to the CSRS (for instance, unnecessary sun exposure on the webbing).

Special Health Needs

- ▶ School bus drivers need extra training to transport children with special needs.
- ▶ Whenever possible, pre-school age children with special needs should be transferred from a wheelchair to a CSRS
 - Unless their wheelchair and harness system has been tested to be compliant with WC19.



Child Passenger Safety Restraint
Systems on School Buses

CLASSROOM NOTES:

Children with Special Health Needs

- There are special steps that need to be taken for transporting pre-school and children with special needs.
- School bus drivers need to have special training specific to transporting students with special needs.
- Some young children with special needs use wheelchairs.
- Whenever possible, children who use wheelchairs should be transferred to a CSRS
 - Unless their wheelchair/mobility device has been tested to be compliant with WC19.
- Latest version of WC19 requires a wheelchair-anchored crashworthy harness system for wheelchairs designed for children who weigh under 50 pounds.

CLASSROOM NOTES:

WC19 Wheelchair

- ▶ WC19: is a voluntary standard for wheelchair crashworthiness.



Child Passenger Safety Restraint Systems on School Buses

33

- When it is not possible to transfer a child to a CSRS, the wheelchair must be properly tied down and the child must be properly protected.
 - WC19 is a voluntary RESNA standard for wheelchairs used as a seat in motor vehicles. It includes a required crash test and associated performance criteria.
- RESNA is the Rehabilitation Engineering and Assistive Technology Society of North America
 - Proper installation includes the following:
 - Both wheelchair and rider face forward, toward the primary direction of vehicle travel.
 - Use of a lap/shoulder seat belt or use of a WC19 compliant wheelchair anchored harness system (latter only for children under 50 lbs).
 - 4 point tie-down system: 4 straps that attach to four points on the wheelchair and 4 points on the floor. Can be 6 point, for heavy wheelchairs. Check the manufacturer's instructions.

WC19 Wheelchair

- ▶ A wheelchair complying with WC19 standard provides a reasonable measure of safe and suitable seating.
 - During loading and unloading.
 - During normal transportation.
 - In a frontal crash.

CLASSROOM NOTES:

- The standard, most recently revised in December 2012, is RESNA WC/Vol.4 - Section 19 Wheelchairs – Wheelchairs Used as Seats in Motor Vehicles.
- It is known as WC19.
- A wheelchair that complies with WC19 can be considered to provide a reasonable measure of safe and suitable seating.
 - During loading and unloading
 - During normal transportation
 - In a frontal crash
- WC19 also requires 4 clearly marked and easily identifiable tie-down locations. In addition, the wheelchair’s design should allow for better fit and use of the lap/shoulder belt.

CLASSROOM NOTES:

Special Plans

- ▶ IEP: Individualized Education Program, for children 3–21 years of age.
- ▶ IFSP: Individualized Family Service Program, for children Birth–3 years of age.

Child Passenger Safety Restraint
Systems on School Buses

35

- How the child using a wheelchair will be transported should be discussed and planned for by the IEP or IFSP team members. Specific procedures and equipment should be detailed in the IEP or in a family’s IFSP.
 - IEP: Individual Education Program, for children 3-21 years
 - IFSP: Individual Family Service Program, for children Birth-3 years
- Transportation personnel should be a part of the IEP process.
- See Glossary for definition of IEP or IFSP.

CLASSROOM NOTES:

Lap/Shoulder Belts 4 to 5 Year Olds

- ▶ No add-on booster seats are to be utilized.
- ▶ Use adjustment features inherent to the system to fit appropriate children.
- ▶ If cannot achieve proper fit utilize different CSRS.



Child Passenger Safety Restraint
Systems on School Buses

4

- Lap/shoulder belts are only appropriate for the 4 to 5 year old pre-school age child who can be properly secured using only the adjustment features inherent to the system.
- If the lap/shoulder belt cannot be properly fitted another CSRS should be utilized which can better meet the child's needs and is suitable for their weight and height.



BE SURE TO

Position the shoulder-height adjuster at or just above the shoulder. The belt should not cross the face or neck.

School bus seats have a height adjuster and therefore do not need a booster seat.

CLASSROOM NOTES:

How to Use Guide

Lap-Shoulder Belt Basics

"Buckle, Check, Tight — Your Seat Belt Is Right!"

Common Seat Belt Parts



Please read all the text above for that safety instruction with my DMI.

Shoulder belt length	56
DMI	56
BIOM	56

BUCKLE



A **BUCKLE** the latch plate into the mating buckle after pulling out the shoulder belt webbing and tightening for the buckle.

CHECK



B **CHECK** that the buckle connection is secure by hugging firmly on the seat belt latch plate.

TIGHT



C **TIGHTEN** the lap portion by pulling upward on the shoulder belt. Be sure that the shoulder belt is snug across the chest and crosses the center of the shoulder.

CLASSROOM NOTES:

Chapter 6: Proper Use of Lap/Shoulder Belts

121

CLASSROOM NOTES:

Pre- and Post-Regulation Latch Plate Differences

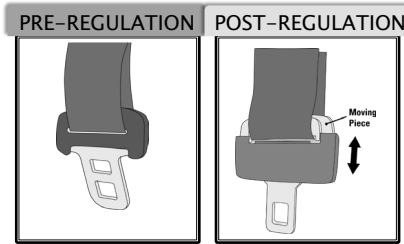

Flow Through Sliding Latch Plate

Locking Latch Plate

- ▶ Both require the shoulder belt to be tightened for proper securement adjustment.
- ▶ Flow through design may require occasional readjustment during time of use as passenger moves about.

Main difference is use of flow through latch plate (pre) versus locking latch plate (post).

Rear-Facing Infant Seat and Forward-Facing Child Seat

- ▶ Pre-regulation requires an extra step.
- ▶ Once the locking clip is securely on the seat belt, buckle the seat belt again.
- ▶ It shouldn't be easy to buckle; if it is re-tighten the belt again and re-do the locking clip.

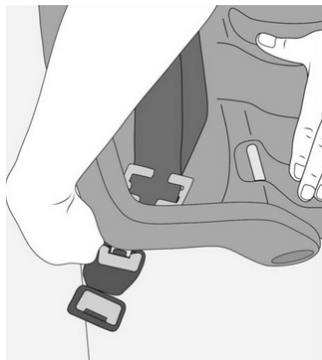

Child Passenger Safety Restraint Systems on School Buses

12

CLASSROOM NOTES:

Once the locking clip is securely on the seat belt, buckle the seat belt again.

When properly tightened, child seat should not move more than 1 inch when checked at the belt path.

CLASSROOM NOTES:

Evacuation



Child Passenger Safety Restraint Systems on School Buses

3

All schools need to establish policies and procedures about how to evacuate a school bus carrying pre-school age children in case of an emergency.

CLASSROOM NOTES:

Safe Location Exercise

Lap belts – all Seating Positions

- ▶ A. Adult aide
 - ▶ B. 7 mos., 24 lbs.
 - ▶ C. 3½ yrs., 50 lbs. behavior problem
 - ▶ D. 2 yrs., 30 lbs.
 - ▶ E. 4 yrs., 45 lbs.
 - ▶ F. 4½ yrs., 65 lbs.
 - ▶ G. 3 yrs., 35 lbs., brittle bones
-
- ▶ RF seat < 35#, conv. seat <35#, 2 comb seats < 65#, 2 Safety Vests, 2 Add-on school bus specific seats

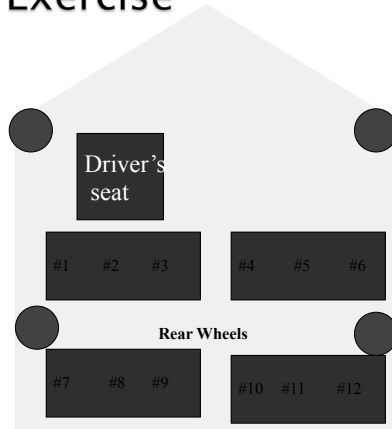

Child Passenger Safety Restraint
Systems on School Buses

4

- Before a student ever rides a school bus the driver should know how they will evacuate the school bus.

CLASSROOM NOTES:

What are the students' abilities?

- Know your students



Child Passenger Safety Restraint Systems on School Buses

5

- Which students can get off the school bus by themselves or with very little help?
- Which students can be removed from the bus without their CSRS?
- Which students must not be removed from their CSRS?
- Which students have essential equipment that also must be removed?
 - Plan must not rely on a student's use of mobility aides (i.e. wheelchair, crutches, canes, etc.).

Individualized Evacuation Plans

- ▶ Know your population.
- ▶ Work with all available resources to identify each child’s needs and abilities.



6

CLASSROOM NOTES:

- Pre-school age children will need some type of assistance.
- What level of assistance does the child need or provide?
 - Verbal prompt/command
 - Physical prompt
 - Hand held
 - Total lift (need only)

CLASSROOM NOTES:

Who can help?



Child Passenger Safety Restraint Systems on School Buses

8

What personnel will be available to help you?

- Know which students can help others get off the school bus.
- Know where emergency medical providers are available along your route (fire stations, hospitals, police, clinics).
- Local emergency response teams should be invited to participate in evacuation drills.
- When accepting help from passersby, be sure to give clear concise directions and closely supervise them to be certain that your expectations for the safety of the children are being met.

Things to include in the written plan:

- A seating plan that identifies where each student sits
- Information on how to evacuate each student
- The location of emergency evacuation equipment

CLASSROOM NOTES:

**Route
Specific
Evacuation
Plans**

Child Passenger Safety Restraint
Systems on School Buses

9

- Know the population on the bus.
 - Have a seating chart.
 - Attempt to predict the interaction between the children.
 - Plan for the order of student evacuation.
 - Children in CSRS should not sit in emergency exits.
- Have emergency medical cards.
- Conduct team rehearsals of who will do what (if other adults are on the bus).
- Know where assistance may be on the route (fire station, police department, medical clinics, or hospitals).

Managing Student Interaction with Others



Child Passenger Safety Restraint Systems on School Buses

CLASSROOM NOTES:

- The route specific plan should take into account interaction between students which might be predicted based on the needs identified in individual student plans.
- Using a rope or other object to help guide/contain pre-schoolers who may want to wander after they exit the school bus.

CLASSROOM NOTES:

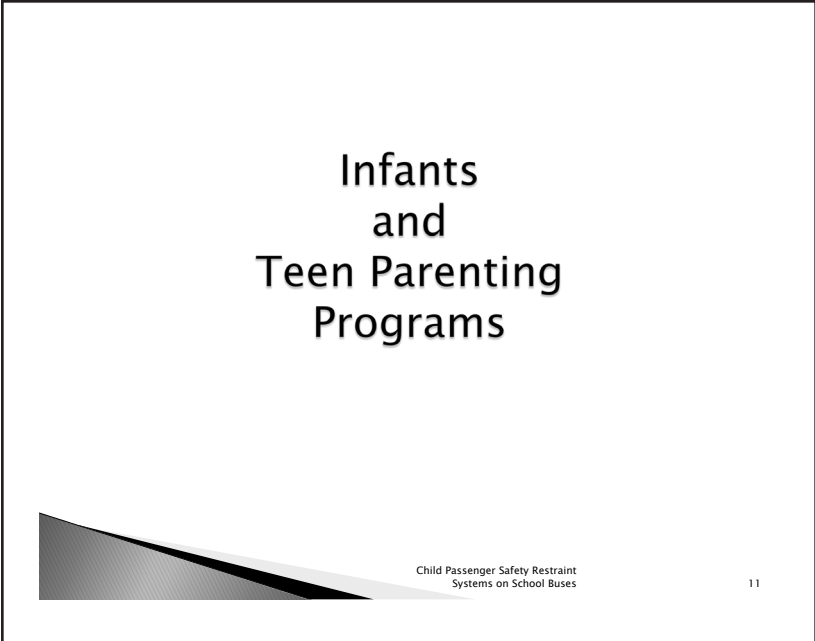

When infants are transported on a school bus either due to teen parenting programs or other early intervention services, the participant would be advised to evacuate the rear-facing CSRS by cutting the webbing on the lap belt and evacuating the infant in the CSRS.

Considerations for Removing the Child from the Seat

- ▶ Size of the child.
- ▶ Size of the CSRS.
- ▶ Width of bus aisle.
- ▶ Ease of removal of the child from the CSRS.
 - Releasing the buckle.
 - Cutting the harness.
- ▶ Physical capabilities of the driver/attendant.
- ▶ Need for containment outside of the bus.
- ▶ Time constraints to evacuate.

Child Passenger Safety Restraint
Systems on School Buses

12

CLASSROOM NOTES:

- Due to the potential variance of a child's size from 20 to 65 pounds riding in a forward-facing CSRS, the first consideration is whether to evacuate the child in or out of the CSRS.
- Options to consider include:
 - Releasing the buckle and evacuating the child
 - Cutting the harness and evacuating the child
 - Lifting/carrying the child in the CSRS
 - Dragging the CSRS with the child in it
 - Dragging multiple CSRS with children in them on an evacuation aide
- Students seated in wheelchairs must be removed from their wheelchair and carried or dragged out of the bus.
 - Drivers must be trained to lift/carry these students to ensure safety of the student and themselves.
 - Some children can be placed on the floor to allow them to scoot themselves or crawl to an exit door.

CLASSROOM NOTES:

Adequate Aisle Width

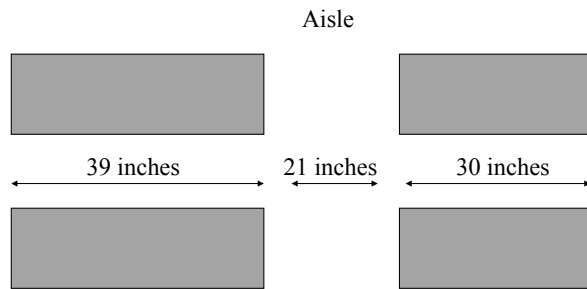

Child Passenger Safety Restraint
Systems on School Buses

13

Aisle width

The standard school bus aisle on a regular bus is 12 inches however it is easier to carry/drag CSRS through aisles that are wider than 12 inches.

Integrated Seats



Child Passenger Safety Restraint Systems on School Buses

14

CLASSROOM NOTES:

- In the essence of time, the first option is to release the buckle.
- If the belt cutter is used, make 2 cuts below the retainer clip then slide the retainer clip down off the webbing and remove the child.

CLASSROOM NOTES:

Safety Vest with Portable Seat Mount

- ▶ Cut below the buckle.



Child Passenger Safety Restraint
Systems on School Buses

15

When evacuating the student in a safety vest the vest webbing is never cut. One cut of the portable seat mount webbing below the buckle will allow the child to evacuate the bus wearing the safety vest.

CLASSROOM NOTES:

Child is Lead Out of the Bus Using the Strap



Child Passenger Safety Restraint
Systems on School Buses

With a 2-part vest the vest and the attached top strap of the portable seat mount can be used to guide the student from the bus and secure him/her outside the bus.

School Bus Specific CSRS



CLASSROOM NOTES:

- In the essence of time, the first option is to release the buckle.
- If the belt cutter is used, make 2 cuts below the retainer clip then slide the retainer clip down off the webbing and remove the child.

CLASSROOM NOTES:

Evaluation of the Evacuation Drill

- ▶ What worked?
- ▶ What did not work?
- ▶ How to effectively remedy the problems?

Child Passenger Safety Restraint
Systems on School Buses

19

What worked?

- All children were evacuated in less than two minutes.
- All children were evacuated to a safe environment approximately 200 feet from the scene.
- All equipment was used properly.
- Bus driver/attendant worked together as a team.
- Evacuation was conducted in an orderly manner.
- Appropriate emergency exits were used.
- Outcomes of the drill were reviewed and discussed with the team.

CLASSROOM NOTES:

Lined area for taking classroom notes, consisting of 30 horizontal lines.



Appendix

Guideline for the Safe Transportation of Pre-school Age Children in School Buses

National Highway Traffic Safety Administration
February 1999

Introduction

School age children transported in school buses are safer than children transported in motor vehicles of any other type. Large school buses provide protection because of their size and weight. Further, they must meet minimum Federal motor vehicle safety standards (FMVSSs) mandating compartmentalized seating, improved emergency exits, stronger roof structures and fuel systems, and better bus body joint strength.

As more pre-school age children are transported to school programs, often in school buses, the public is increasingly asking the National Highway Traffic Safety Administration (NHTSA) about how to safely transport them. To help answer these questions, NHTSA conducted crash testing of pre-school age size dummies in school bus seats. The test results showed that pre-school age children in school buses are safest when transported in child safety restraint systems (CSRSs) that meets FMVSS 213, Child Restraint Systems, and are correctly attached to the seats.

Based on its research, NHTSA recommends pre-school age children transported in school buses always be transported in properly secured CSRSs. In partial response to questions from school (and child care) transportation offices, this Guideline seeks to assist school and other transportation managers in developing and implementing policies and procedures for the transportation of pre-school age children in school buses.

Note: The proper installation of CSRSs necessitates that a school bus seat have safety belts or other means of securing the CSRS to the seat. NHTSA recommends that lap belts or anchorages designed to meet FMVSS 225, Tether Anchorages and Child Restraint Anchorage Systems, be voluntarily installed to secure CSRSs in large school buses.

RECOMMENDATIONS FOR THE TRANSPORTATION OF PRE-SCHOOL AGE CHILDREN IN SCHOOL BUSES

When pre-school age children are transported in a school bus, NHTSA recommends these guidelines be followed:

- (1) Each child should be transported in a Child Safety Restraint System (suitable for the child's weight and age) that meets applicable Federal Motor Vehicle Safety Standards (FMVSSs).
- (2) Each child should be properly secured in the Child Safety Restraint System.
- (3) The Child Safety Restraint System should be properly secured to the school bus seat, using anchorages that meet FMVSSs.

Child Safety Restraint System Defined

A Child Safety Restraint System is any device (except a passenger system lap seat belt or lap/shoulder seat belt), designed for use in a motor vehicle to restrain, seat, or position a child who weighs less than 50 pounds.

Child Safety Restraint Systems Guideline

1. Child Safety Restraint System Specifications

The provider of the CSRS should ensure:

Each pre-school age child to be transported has a CSRS appropriate for the child's weight, height, and age.

Each CSRS meets all applicable FMVSSs (look for the manufacturer's certification on the label attached to the system).

Each CSRS has been registered with the CSRS's manufacturer to facilitate any recalls the manufacturer might conduct.

If the CSRS is the subject of a recall, any necessary repairs or modifications have been made to the manufacturer's specifications.

Each CSRS is maintained as recommended by its manufacturer, including disposal of any CSRS that has been involved in a crash.

2. Proper Securement

The transportation provider should ensure:

The CSRS is used and secured correctly in the school bus.

Each child is secured in CSRSs according to manufacturer's instructions.

All CSRS attachment hardware and anchorage systems meet FMVSS 210, Seat Belt Assembly Anchorages or FMVSS 225, Tether Anchorages and Child Restraint Anchorage Systems.

School bus seats designated for CSRSs meet FMVSS 225, or include lap belts that meet FMVSS 209, Seat Belt Assemblies, and anchors that meet FMVSS 210 (designed to secure adult passengers or CSRS).

Personnel responsible for securing CSRSs onto school bus seats and children into CSRSs are properly trained and all personnel involved with CSRSs are provided up-to-date information and training.

When transported in the school bus, pre-school age children are supervised according to their developmental and functioning level.

3. School Bus Seats Designated for Child Safety Restraint Systems

The transportation provider should ensure:

School-bus seats designated for CSRSs are located starting at the front of the vehicle to provide drivers with quick access to and a clear view of the CSRS occupants.

CSRS anchorages on school bus seats should meet all applicable FMVSSs.

When ordering new school buses, the maximum spacing specified under FMVSS No. 222, School Bus Passenger Seating and Crash Protection, (within 24 inches from the seating reference point) is recommended for seats designated for CSRSs to provide adequate space for the CSRSs.

The combined width of CSRS and/or other passengers on a single seat does not exceed the width of the seat.

If other students share seats with the CSRSs, the CSRSs are placed in window seating position.

4. Retrofitting School Buses

The transportation provider should ensure:

Existing school bus seats should only be retrofitted with lap belts or child restraint anchorages as instructed by the school bus manufacturer.

When a school bus is retrofitted with a seat to allow for proper securement of a CSRS, instructions obtained from the school bus or seat manufacturer on how to install the seat and restraint systems should be followed.

When a school bus is retrofitted, the bus owner should ensure that seat spacing is sufficient for the CSRS to be used.

5. Evacuation

The transportation provider should ensure:

The establishment of a written plan on evacuating pre-school age children and other passengers in CSRSs in the event of an emergency. This written plan should be provided to drivers, monitors, and emergency response personnel. The plan should explicitly state how children (both in and out of the CSRS) should be evacuated from the school bus.

Evacuation drills are practiced on a scheduled basis, at least as often as that required for the school system's school-aged children.

All personnel involved in transporting children are trained in evacuation and emergency procedures, including those in the written school bus evacuation plan.

All school buses carrying children in CSRSs carry safety belt cutters that are accessible only to the driver and any monitors.

CSRSs are not placed in school bus seats adjacent to emergency exits.

Local emergency response teams are provided copies of the written school bus evacuation plan, including evacuation of pre-school age children. Emergency response personnel should be invited to participate in evacuation drills.

6. Other Recommendations

The school transportation provider should establish a policy on whether they or the child's guardian must supply a CSRS to be used on a school bus. School bus purchases should be based on the needs of a projected student population, taking into consideration projected ages, sizes, and other characteristics of the students, including any special needs, and whether pre-school age children or medically fragile students will be transported.

Specified procedures should be established for loading and unloading children in CSRSs.

Procedures should be established for the periodic maintenance, cleaning, and inspection for damage of CSRSs. Procedures should be established to train personnel involved in direct service delivery of infants, toddlers, and pre-school children on the physical day-to-day handling of these young children and means to handle potential exposure to contagious and communicable diseases.

When school bus procedures are established, it should be noted that some children in CSRSs may have special needs, including medical fragility, that must be addressed on a child-by-child basis.

Federal Laws Guiding Special Education

U.S. Constitution-Fourteenth Amendment

The U.S. Constitution provides that no state may deny any person within its jurisdiction the equal protection of the laws. A state must treat all persons alike. Therefore, disabled individuals are provided this “equal protection” of access to school bus transportation services.

Individuals with Disabilities Education Act 1990 (IDEA) (formerly the Education for all Handicapped Children Act of 1975

The individuals with Disabilities Education Act requires public schools to make available to all eligible students with disabilities a free appropriate public education (FAPE) in the least restrictive environment (LRE) appropriate to their individual needs. This changed the terminology of “handicapped children” to “children with disabilities” and broadened the definition of the terms “assistive technology device” and “assistive technology service.” IDEA mandates public school systems to develop an Individual Education Program (IEP) for each child. The specific special education and related services outlined in each IEP reflects the individualized needs of each student. The language for training and personnel development for can be found below in Section 662 (b) (1) (A) of IDEA:

Section 602(26) Related services.--

(A) In general.--The term `related services' means transportation, and such developmental, corrective, and other supportive services (including speech-language pathology and audiology services, interpreting services, psychological services, physical and occupational therapy, recreation, including therapeutic recreation, social work services, school nurse services designed to enable a child with a disability to receive a free appropriate public education as described in the individualized education program of the child, counseling services, including rehabilitation counseling, orientation and mobility services, and medical services, except that such medical services shall be for diagnostic and evaluation purposes only) as may be required to assist a child with a disability to benefit

from special education, and includes the early identification and assessment of disabling conditions in children.

(B) Exception.--The term does not include a medical device that is surgically implanted, or the replacement of such device.

Sec. 662. Personnel development to improve services and results for children with disabilities.

(b) Personnel Development; Enhanced Support for Beginning Special Educators.--

(1) In general.--In carrying out this section, the Secretary shall support activities--
246 Child Passenger Safety Restraint Systems in School Buses National Training
(A) for personnel development, including activities for the preparation of personnel who will serve children with high incidence and low incidence disabilities, to prepare special education and general education teachers, principals, administrators, and related services personnel (and school board members, when appropriate) to meet the diverse and individualized instructional needs of children with disabilities and improve early intervention, educational, and transitional services and results for children with disabilities, consistent with the objectives described in subsection (a);

**Individuals with Disabilities Education Act (IDEA); Federal register/Vol. 64, No. 48/
Friday, March 12, 1999/Rules and Regulations 34 CFR Part 303 Early Intervention
Program for Infants and Toddlers with Disabilities (Part C of the Individual with
Disabilities Act)**

This section encourages states to maintain and implement a statewide comprehensive, coordinated, multidisciplinary, interagency system of early intervention services for infants and toddlers with disabilities and their families. Early intervention services also include transportation and related cost of travel that are necessary to enable eligible children under this part and their families to receive early intervention services.

Therefore, districts may provide transportation services to infants and toddlers with disabilities as part of a local program or part of an interagency program.

**The Education of All Handicapped Children's Act Amendments of 1986 (EHCA)
Part H**

Part H addressed the need for early intervention for infants and toddlers. States were offered financial incentives to establish an extensive, statewide service among numerous agencies that would be provided to children from birth through two years of age. In addition, it lowered the age of eligibility for special education and related services for all children with disabilities to age three and required that all eligible children receive early intervention services. This law also required that services be specified in the Individualized Family Service Plan (IFSP). The responsibilities of transportation services are defined as the cost of travel that is necessary to enable an eligible child and the child's family to receive early intervention services.

The Handicapped Children's Protection Act of 1986 (P.L. 99-372)

This law amended EHA to authorize the award of reasonable attorney's fees to parents who prevail in due process hearings and judicial proceedings in dispute over special education and related services.

The Education For All Handicapped Children Act of 1975 (Pub. L. 94-142) (EHCA)

The Education For All Handicapped Children Act guaranteed a "free appropriate public education" (FAPE), including special education and related services, to all handicapped children.

It also provides funding to help states bear the additional costs they would incur in educating handicapped students. It provides that they must be educated with other, non disabled students to the extent possible (Least Restrictive Environment) and establishes an elaborate system of procedural safeguards to ensure parental input. Persons involved with the student's special education program must be appropriately trained.

Transportation services may include schools, travel in and around school buildings, specialized equipment (lift buses), counseling, or social work services.

The Family Education Rights and Privacy Act of 1974 (FERPA)

The privacy rights of students extend to education records maintained by a school district and by a person acting for the school district. Personal notes made by a driver concerning a student for their own use and not available to other persons, except a substitute driver, are not subject to FERPA. Disclosure of "personally identifiable information" about a

student to persons other than professional personnel employed in the school district is prohibited without parental consent. Parental consent is the guiding principle regarding the release or exchange of student records and information in those records. Emergency information should be carried on the bus at all times to provide appropriate identification for students in emergency situations.

Section 504 of The Rehabilitation Act of 1973 (Pub. L. 93-112)

The Rehabilitation Act prohibits discrimination against individuals with disabilities by any recipient of federal funding, including public schools. Section 504 covers persons with a disability who would otherwise be qualified to participate in and benefit from programs or other activities receiving federal financial assistance. Section 504 has been used as the foundation for special education complaints involving transportation services, such as access to bus service, length of ride, transportation costs to parents, loss of instructional time, suspension, method of transportation, and specialized needs.

The Civil Rights Act of 1994 and The Education Amendments of 1972 (Title VI, Title VII and Title IX)

These laws protect the civil rights and equal education opportunities of all individuals regardless of race, color, religion, sex, or national origin. Harassment and discriminatory behavior that denies civil rights or access to equal educational opportunities include comments, name calling, physical conduct or other expressive behavior directed at an individual or group that intentionally demeans the race, color, religion, sex, or national origin of the individual(s) or creates an intimidating, hostile, or demeaning environment for education.

The Reauthorization of IDEA 2004 (Individuals with Disabilities Education Improvement Act)

This law, as amended by the 2004 changes, will not provide mandatory full funding. Although the annual amounts now authorized to be spent on IDEA would achieve full funding in six years, that assumes these amounts will actually be appropriated and explains why mandatory funding of IDEA is so important. A new provision in the Act authorizes the Secretary to issue only regulations necessary to secure compliance with the

statute. This provision may limit the Secretary's authority to issue regulations that could be useful in clarifying ambiguities. A new section of the Act also suggests that states minimize the number of rules, regulations and policies to which the school districts are subject.

248 Child Passenger Safety Restraint Systems in School Buses National Training The No Child Left Behind Act 2001

The No Child Left Behind Act is a plan for comprehensive education reform. This law provides for stronger accountability for results, expanded flexibility and local control, expanded options for parents, and an emphasis on teaching methods that have been proven to work. Public school choice, Charter Schools and supplemental services are some of the issues that will impact transportation for school districts.

Americans with Disabilities Act of 1990.

This law affords legal rights to persons with disabilities by expanding access to facilities. ADA involves access issues and design standards. The American National Standards Institute (ANSI) standards detail how accessibility is to be achieved in new construction and alterations, specifications for various building elements and spaces, including entrances, ramps, parking, restrooms and telephones, among others. ADA is the continuum of Section 504. The Department of Justice enforces ADA.

Child Passenger Safety Glossary of Terms

Active Protection: Protection features that require action by the occupant. These features include lap belts, lap and shoulder belts, and child restraint systems.

Anchor: A common short alternative for anchorage; often used to refer specifically to the hardware installed at the anchorage, either factory-installed or in a retrofit shoulder-belt or tether kit.

Add-on school bus specific CSRS: A CSRS designed to be used exclusively on a school bus. It incorporates a seat base, back and a five point harness system. It is secured to the school bus seat with a cam wrap or portable seat mount.

Allowable alternate vehicle: A vehicle designed for carrying eleven or more people, including the driver, that meets all the Federal Motor Vehicle Safety Standards applicable to school buses except 49 CFR 571.108 and 571.131. (See also *Multifunction School Activity Bus*.)

Anchorage: See anchor.

Belt cutter: See Seat belt cutter

Belt-positioning booster seat (BPB): A crash-tested device that raises the child so that the required lap and shoulder belts fit correctly. All BPBs act as pre-crash positioning devices and must be used with lap and shoulder belts. BPB models may have high backs, or be backless.

Belt sensitive: Refers to a type of emergency locking retractor, which locks when the belt is pulled quickly.

Belt path: The path that the manufacturer is required to create so that the seat belt passes around or through the CSRS. Some seats have multiple belt paths. For example, convertible car seats have one belt path for rear-facing use and a separate one for forward-facing use.

Best practice: Suggested options that represent most acceptable ways to travel for a child of certain age, size, physical development, and behavioral needs. Best practice may vary given real world circumstances.

Booster seat: See belt-positioning booster seat.

Buckle: The locking mechanism of the vehicle belt or child safety seat. The latchplate fits (clicks) into the buckle.

Caregiver: A person responsible for a child's well-being and safety.

CPS: Child passenger safety.

Cam wrap: A seat-mounted system for attaching a safety vest to a school bus seat. (See Portable seat mount)

Car seat: See Child Restraint

Child restraint (CR), child restraint system (CRS), child restraint device (CRD) child safety restraint system (CSRS): A crash-tested device or system that is specially designed to provide infant/child crash protection. General term for systems including child safety seats, safety vests or car beds that meet FMVSS 213.

Children with special transportation needs: Children whose physical or behavioral conditions makes the use of particular, often specially designed, restraint systems necessary.

Combination seat: A type of forward-facing child restraint that is used with an internal harness system to secure a child. With removal of the internal harness, it is used as a belt-positioning booster (BPB) seat.

Compartmentalization: Refers to the type of passive occupant protection seen in school buses.

CR: See Child Restraint

Convertible child safety seat: A child restraint that “converts” from rear-facing for infants and smaller children to forward-facing for children.

Crash Dummies: Full-scale replicas of human beings, weighted and articulated to simulate the behavior of a human body in a vehicle mishap, and instrumented to record as much data as possible on numerous variables during a collision.

Detachable Base: A separate base for a child restraint system that can be installed in the vehicle. The restraint (car seat) portion can be removed from the base, and used as an infant carrier.

Emergency locking retractor (ELR): A retractor on a seat belt system that locks in response to rapid deceleration of the vehicle. ELRs respond to rapid movement of the belt or the sudden deceleration of the vehicle or both.

Evacuation device: Specially designed device with handles to effectively drag a person or CSRS to an exit and away from the bus.

Fire blanket: Chemically treated blanket used to cut off the oxygen supply to a fire and could also be used to keep a child warm in the case of injury or shock.

Forward-facing-only child safety seat: A child restraint system that is intended for use only in the forward-facing position for a child that has outgrown his/her rear facing seat.

Harness: A system of straps that keep the child within the shell, distributes crash forces, and helps the child “ride down” the crash.

Harness retainer clip or Chest Clip: A clasp that holds the shoulder straps together over the child’s chest at armpit level. Pre-crash positioning device intended to keep harness straps in position on the shoulders.

Harness adjuster: Used to tighten or loosen the harness the internal harness of a child

restraint system.

Harness slots: Slots in the child restraint through which shoulder straps are routed. See Shoulder Harness Slots.

Head excursion: The distance from a reference point that the occupant's head travels forward during a frontal impact. A performance measure regulated by FMVSS 213.

High Back Booster Seats: see Belt Positioning Booster.

IEP: Individualized Education Program, for children 3-21 years. The IEP is the blueprint for the education and related services that the local education agency (LEA) provides for a child with a disability, together with the goals, academic assessment procedures, and placement of the child.

IFSP: Individualized Family Services Plan. For children 0-3 years and their family an IFSP is developed in coordination with his/her teacher, day care center, school, or school district to provide for a particular child's special needs. Because infants and toddlers are served in a variety of locations (including the home), Part C of IDEIA services (see appendix) are to be provided in "natural environments in which children without disabilities participate" to the maximum extent appropriate.

Infant-only safety seat: A child restraint designed for use only by a young child in a semi-reclined rear-facing position. Also referred to as rear-facing only car seat.

Integrated child seat: A child-sized forward-facing restraint with a full harness built into a school bus seat.

Labels: These are located on the seat, and indicate the following: 1) NHTSA certification of conformation to all applicable FMVSS 2) Weight and height guidelines for the specific seat 3) Basic outline of the installation procedures 4) Manufacturing data, including data of manufacture, the manufacturer's name and address, and a model number 5) Air bag warning and 6) FAA certification for use in an aircraft.

LATCH: Lower Anchors and Tethers for Children.

Latch plate: The part of the buckle mechanism that locks or connects into the buckle. May be the part that adjusts the length of the lap portion of the belt webbing.

Level Indicator: Helps to identify the manufacturer's recommended correct angle for rear-facing restraints.

Lock-off: A built-in belt-locking feature on the child restraint system that works with certain types of seat belts in a similar fashion as locking clips.

Locking clip: A flat H-shaped metal item intended to clip lap and shoulder belt webbing together at a free-sliding latch plate in order to prevent the webbing from sliding through. A locking clip is a pre-crash positioning device only. It is not to be used as a belt shortening clip.

Lower anchorage attachments: A piece of belt webbing that anchors to the lower anchorage on the vehicle structure. It secures the CSRS to the vehicle. These attachments are used in place of the vehicle seat belt.

Multifunction School Activity Bus (MFSAB): “A school bus whose purposes do not include transporting students to and from home or school bus stops,” as defined in 49 CFR 571.3. This subcategory of school bus meets all FMVSS for school buses except the traffic control requirements (alternately flashing signal and stop arm).

Non-regulated (aftermarket) products: As the name implies there are no federal standards for these products. Some examples are infant head positioning pads, shoulder belt positioning pads and shoulder belt positioning devices. Manufacturer–tested and approved accessories for their own CSRS are acceptable.

Ossification: The natural process of bone formation.

Passive occupant protection: Features of the vehicle that lessen the injury to the occupant without any action taken by the occupant.

Portable seat mount: A long wide strip of webbing that wraps around the vehicle seat back and is fastened around the vehicle seat. Used with safety vests or school bus specific CSRS.

Rear-facing only seat: A child restraint designed for use only by a young child in a semi-reclined rear-facing position. Also referred to as infant only car seat.

Rebound: Reactive motion in the opposite direction after initial impact has occurred.

Recalls: Voluntary or required actions taken to correct problems or deficiencies once products have been distributed or sold. Manufacturers must offer free repairs or replacement for products recalled for violations of safety standards.

Recline Adjustor: Allows convertible restraints to be reclined for rear-facing and semi-reclined or upright for forward-facing use.

Registration card: A postage-paid return card that comes with every child restraint; should be returned to the manufacturer so owners can be notified of any recalls.

Retractor: A mechanism that rolls up the webbing of the seat belt when it is not in use and takes up slack around the user.

Retrofitted: Installing, fitting, or adapting a device or system. An example of this would be to retrofit seat belts on a school bus.

Ride Down: The length of time when the forces are felt by the occupant during a crash.

Seat belt: The buckle, retractor, anchor, webbing and latch plate system that restrains the occupant in the vehicle. Also known as a seat belt.

Seat belt cutter: A device used to cut webbing.

Safety vest: A combination pelvic and upper torso child restraint system that consists primarily of flexible material, such as straps, webbing or similar material, and that does not include a rigid seating structure for the child. A cam wrap must be used for installation on a school bus seat.

School bus: A bus owned, leased, contracted to or operated by a school or school district and regularly used to transport students to and from school or school-related activities, but not including a charter bus or transit bus. A school bus must meet all applicable FMVSSs and is

readily identified by alternately flashing lamps, National School Bus Yellow paint, and the legend "School Bus," except as may be provided for the multifunction school activity bus.

School bus specific CSRS: A CSRS designed to be used exclusively on a school bus. It incorporates a seat base, back and a five point harness system. It is secured to the school bus seat with a cam wrap or portable seat mount.

School bus specific lap belt add-on CSRS: A CSRS used in conjunction with a lap belt meeting all applicable FMVSS's which meets FMVSS 213 and is designed to be used exclusively on a school bus. It incorporates harness and crotch straps and is secured to the bus seat with a cam wrap or portable seat mount.

Seat Belt Syndrome: Separation of the lumbar vertebrae and associated paralysis, due to the effects of a crash where only a lap belt was used.

Seat bight: The intersection between the bottom vehicle seat cushion and the back cushion. The seat crack.

Seat padding: The cushioning attached to a child restraint, on which the child sits.

Shell: The molded plastic structure of the CSRS. In some models, the shell is attached to or reinforced by a metal frame.

Splitter plate: Metal plate that connects the two ends of the shoulder harnesses to a single piece of webbing used for adjustment.

Submarining: When the hips and legs slide forward out of the harness and the upper body remains restrained.

Technician: A person who successfully completes the National Highway Traffic Safety Administration's (NHTSA) standardized child passenger safety certification program.

Tether: See Tether Strap

Tether anchor: The kit or installed hardware bracket used to secure the tether hook and strap at the designated anchor point in the vehicle. The tether strap and hook attach directly to the anchor bracket.

Tether strap: A piece of belt webbing that anchors the top of the CSRS to the vehicle structure. It keeps the restraint from tipping forward on impact and can provide an extra margin of protection. Can be optional or factory installed.

Webbing: The fabric of the seat belt that holds the occupant or a CSRS in place.

Quick Reference Guide to Federal Motor Vehicle Safety Standards and Regulation

Foreword

The National Highway Traffic Safety Administration (NHTSA) has a legislative mandate under Title 49 of the United States Code, Chapter 301, Motor Vehicle Safety, to issue Federal Motor Vehicle Safety Standards (FMVSS) and Regulations to which manufacturers of motor vehicles and items of motor vehicle equipment must conform and certify compliance. FMVSS 209, Seat Belt Assemblies, was the first standard to become effective on March 1, 1967. A number of FMVSS became effective for vehicles manufactured on and after January 1, 1968. Subsequently, other FMVSS have been issued. For instance, NHTSA has issued seven new FMVSS and has amended six FMVSS and two consumer information regulations and requirements since this booklet was revised in March 1999. New standards and amendments to existing standards are published in the Federal Register.

These Federal safety standards are regulations written in terms of minimum safety performance requirements for motor vehicles or items of motor vehicle equipment. These requirements are specified in such a manner that the public is protected against unreasonable risk of crashes occurring as a result of the design, construction, or performance of motor vehicles and is also protected against unreasonable risk of death or injury in the event crashes do occur.

This booklet lists the Federal Motor Vehicle Safety Standards that were in effect as of October 2003, and provides a brief summary of each safety standard. It also provides similar information on other Federal consumer information regulations and requirements.

Title 49: Chapter V - National Highway Traffic Safety Administration
Department of Transportation

Part 571 **Federal Motor Vehicle Safety Standards**

Subpart B—	Federal Motor Vehicle Safety Standards 571.101– 571.500
<u>Standard No. 101:</u>	Controls and Displays
<u>Standard No. 102:</u>	Transmission Shift Lever Sequence, Starter Interlock, and Transmission Braking Effect
<u>Standard No. 103:</u>	Windshield Defrosting and Defogging Systems
<u>Standard No. 104:</u>	Windshield Wiping and Washing Systems
<u>Standard No. 105:</u>	Hydraulic and Electric Brake Systems

<u>Standard No. 106:</u>	Brake Hoses
<u>Standard No. 107:</u>	[Reserved]
<u>Standard No. 108:</u>	Lamps, Reflective Devices, and Associated Equipment
<u>Standard No. 109:</u>	New Pneumatic Bias Ply and Certain Specialty Tires*
<u>Standard No. 110:</u>	Tire Selection and Rims for Motor Vehicles*
<u>Standard No. 111:</u>	Rearview Mirrors
<u>Standard No. 112:</u>	[Reserved]
<u>Standard No. 113:</u>	Hood Latch System
<u>Standard No. 114:</u>	Theft Protection
<u>Standard No. 115:</u>	[Reserved] Requirements moved to Part 565—Vehicle Identification Number
<u>Standard No. 116:</u>	Motor Vehicle Brake Fluids
<u>Standard No. 117:</u>	Retreaded Pneumatic Tires
<u>Standard No. 118:</u>	Power-Operated Window, Partition, and Roof Panel Systems
<u>Standard No. 119:</u>	New Pneumatic Tires for Vehicles Other Than Passenger Cars*
<u>Standard No. 120:</u>	Tire Selection and Rims for Motor Vehicles Other Than Passenger Cars
<u>Standard No. 121:</u>	Air Brake Systems
<u>Standard No. 122:</u>	Motorcycle Brake Systems
<u>Standard No. 123:</u>	Motorcycle Controls and Displays
<u>Standard No. 124:</u>	Accelerator Control Systems
<u>Standard No. 125:</u>	Warning Devices
<u>Standard No. 129:</u>	New Non-Pneumatic Tires for Passenger Cars—New Temporary Spare Non-Pneumatic Tire Use on Passenger Cars
<u>Standard No. 131:</u>	School Bus Pedestrian Safety Devices
<u>Standard No. 135:</u>	Light Vehicle Brake Systems*

<u>Standard No. 138:</u>	Tire Pressure Monitoring Systems**
<u>Standard No. 139:</u>	New Pneumatic Radial Tires for Light Vehicles**
<u>Standard No. 201:</u>	Occupant Protection in Interior Impact
<u>Standard No. 202:</u>	Head Restraints
<u>Standard No. 203:</u>	Impact Protection for the Driver from the Steering Control System
<u>Standard No. 204:</u>	Steering Control Rearward Displacement
<u>Standard No. 205:</u>	Glazing Materials
<u>Standard No. 206:</u>	Door Locks and Door Retention Components
<u>Standard No. 207:</u>	Seating Systems
<u>Standard No. 208:</u>	Occupant Crash Protection*
<u>Standard No. 209:</u>	Seat Belt Assemblies
<u>Standard No. 210:</u>	Seat Belt Assembly Anchorages
<u>Standard No. 211:</u>	[Reserved]
<u>Standard No. 212:</u>	Windshield Mounting
<u>Standard No. 213:</u>	Child Restraint Systems
<u>Standard No. 214:</u>	Side Impact Protection
<u>Standard No. 215:</u>	[Reserved]
<u>Standard No. 216:</u>	Roof Crush Resistance
<u>Standard No. 217:</u>	Bus Emergency Exits and Window Retention and Release
<u>Standard No. 218:</u>	Motorcycle Helmets
<u>Standard No. 219:</u>	Windshield Zone Intrusion
<u>Standard No. 220:</u>	School Bus Rollover Protection
<u>Standard No. 221:</u>	School Bus Body Joint Strength

<u>Standard No. 222:</u>	School Bus Passenger Seating and Crash Protection
<u>Standard No. 223:</u>	Rear Impact Guards
<u>Standard No. 224:</u>	Rear Impact Protection
<u>Standard No. 225:</u>	Child Restraint Anchorage Systems**
<u>Standard No. 301:</u>	Fuel System Integrity
<u>Standard No. 302:</u>	Flammability of Interior Materials
<u>Standard No. 303:</u>	Fuel System Integrity of Compressed Natural Gas Vehicles
<u>Standard No. 304:</u>	Compressed Natural Gas Fuel Container Integrity
<u>Standard No. 305:</u>	Electric-Powered Vehicles: Electrolyte Spillage and Electric Shock Protection**
<u>Standard No. 401:</u>	Interior Trunk Release**
<u>Standard No. 402:</u>	(Reserved)
<u>Standard No. 403:</u>	Platform Lift Systems for Motor Vehicles**
<u>Standard No. 404:</u>	Platform Lift Installations in Motor Vehicles**
<u>Standard No. 500:</u>	Low Speed Vehicles

Part 531 - Part 595

Subpart B— Other Regulations Relating To Transportation

<u>Part 531:</u>	Passenger Automobile Average Fuel Economy Standards
<u>Part 533:</u>	Light Truck Fuel Economy Standards
<u>Part 541:</u>	Federal Motor Vehicle Theft Prevention Standard
<u>Part 555:</u>	Temporary Exemptions from Motor Vehicle Safety and Bumper Standards
<u>Part 557:</u>	Petitions for Hearings on Notification and Remedy of Defects
<u>Part 564:</u>	Replaceable Light Source Information
<u>Part 565:</u>	Vehicle Identification Number Requirements
<u>Part 566:</u>	Manufacturer Identification
<u>Part 567:</u>	Certification
<u>Part 568:</u>	Vehicles Manufactured in Two or More Stages
<u>Part 569:</u>	Regrooved Tires

Part 570:	Vehicle In Use Inspection Standards
Part 572:	Anthropomorphic Test Devices
	Subpart B —50th Percentile Male Subpart C —3-Year-Old Child Subpart D —6-Month-Old Infant Subpart E —Hybrid III Test Dummy Subpart F —Side Impact Dummy 50th Percentile Male Subpart G-H [Reserved] Subpart I —6-Year-Old Child Subpart J —9-Month-Old Child Subpart K —Newborn Infant Subpart L —Free Motion Headform Subpart M —Side Impact Hybrid 50th Percentile Male Subpart N —Hybrid III 6-Year Old Child Test Dummy, Beta Version Subpart O —Hybrid III 5th Percentile Female Test Dummy, Alpha Version Subpart P —3-Year-Old Child Crash Test Dummy, Alpha Version Subpart R —CRABI 12-Month-Old Infant Crash Test Dummy, Alpha Version
Part 573:	Defect and Noncompliance Reports
Part 574:	Tire Identification and Record Keeping
Part 575:	Consumer Information Regulations
	Subpart B—Consumer Information Items:
	103 —Truck Camper Loading 104 —Uniform Tire Quality Grading Standards 105 —Vehicle Rollover*
Part 577:	Defect and Noncompliance Notification
Part 579:	Defect and Noncompliance Responsibility
Part 580:	Odometer Disclosure Requirements
Part 581:	Bumper Standard
Part 582:	Insurance Cost Information Regulation
Part 583:	Automobile Parts Content Labeling
Part 591:	Importation of Vehicles and Equipment Subject to Federal Safety, Bumper, and Theft Prevention Standards
Part 595:	Retrofit On-Off Switches for Air Bags
	Subpart B —Retrofit On-Off Switches for Air Bags Subpart C —Vehicle Modifications to Accommodate People With Disabilities**

Federal Motor Vehicle Safety Standard No. 213

Highlights of the Regulation for Child Restraint Systems

- Covers all types of systems (infant carriers, child seats, harnesses, and car beds) to restrain children under 80 pounds in motor vehicles.
- Requires that child restraint systems pass a 30 mph frontal sled test, which simulates a crash.
- Specifies maximum rotation during crash test for rear-facing child restraints.
- Specifies limits on child dummy measurements for forward-facing child restraints:
 - Head injury criteria (potential brain injury resulting from abrupt deceleration). Does not apply in tests with 10-year-old dummy (65-80 lbs.).
 - Head excursion (distance dummy head travels forward)
 - Force on chest
 - Knee excursion
- Requires that restraints not break during dynamic tests.
- Requires that child restraints retain a child dummy within the confines of the restraint during crash tests.
- Specifies requirements for foam padding and flame-retardant fabric.
- Requires that safety seats pass the 30 mph test secured with vehicle lap belt or lower LATCH attachments only as well as a more stringent test for forward-facing restraints with a tether anchored. Exceptions: child harnesses and products for children with special needs may be tested with top tether straps anchored. Boosters are tested with a vehicle lap-shoulder belt.
- Specifies the amount of force needed to open buckles on child restraints, so that toddlers cannot unbuckle themselves but adults can easily open the buckle. (Before crash test, minimum force is nine lbs. and maximum is 14 lbs.; after crash test, maximum is 16 lbs.)
- Requires permanent, visible labels on the restraint with the following information: certification that it conforms to standards for use in motor vehicles, basic instructions for correct installation, child weight limits (including maximum weight for use of lower LATCH attachments), name and address of manufacturer/distributor, and date made. Air bag warning label required for rear-facing restraints. The restraint must have a designated location for storing the instruction booklet or sheet. An additional label may be present to state certification for use in aircraft.
- Permits child restraint systems to be designed as an integral part of motor vehicle seats.
- Requires that the manufacturer include a registration card with the child restraint and notify consumers of product recalls.
- Requires that child restraints include LATCH attachments. FMVSS 225 requires that vehicles have LATCH anchors (FMVSS 225).

<p>SafetyBeltSafe U.S.A. P.O. Box 553, Altadena, CA 91003 www.carseat.org 310/222-6860, 800/745-SAFE (English) 310/222-6862, 800/747-SANO (Spanish)</p>

This document was developed by SafetyBeltSafe U.S.A. and may be reproduced in its entirety.
Important: Call to check if there is a more recent version before reproducing this document.

#91 (3-6-12)

LATCH* Requirements

Summary of Changes to Federal Regulations (FMVSS 213 and 225)

Vehicle Requirements:

- ◆ User-ready top tether strap anchorage hardware (such as a ring, bar, bracket, or webbing loop) for three rear seating positions were available in most passenger vehicles beginning with model year 2000 and were required in all cars, minivans, and pick-up trucks by model year 2001.
- ◆ Lower anchors for child restraints, each consisting of two rigid bars 6 mm in diameter and 25-50 mm long, are present in the vehicle seat bight (the crack between the seat back and seat cushion) in specified seating positions in all cars, minivans, and pick-up trucks made after September 1, 2002 (model year 2003), and in many made before that date.
- ◆ Requirements apply to all passenger cars, trucks, and multipurpose passenger vehicles under 8500 lbs.; also apply to buses under 10,000 lbs.
- ◆ Safety belts in all rear seating positions must meet a lockability requirement (be capable of securing a child restraint without added equipment, such as a locking clip). This requirement would have ended on September 1, 2012, but NHTSA granted a petition initiated by SafetyBeltSafe U.S.A. and Safe Ride News to keep the lockability requirement in place.

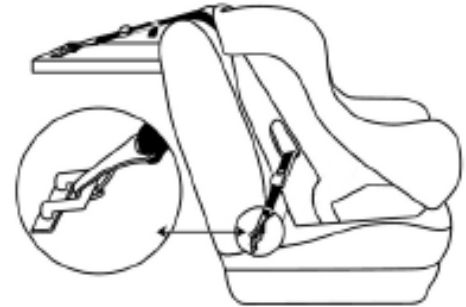

Vehicle Exceptions:

- ◆ No tether anchorage hardware is required for convertible cars or school buses.
- ◆ A built-in child restraint can replace the required anchorage system in one rear seating position.
- ◆ At least one front seating position must have the required anchorage system if the vehicle has an air bag cut-off switch and has either no rear seat or a rear seat too small for a rear-facing child restraint.

Child Restraint Requirements:

- ◆ The head excursion limit (maximum distance the head can travel forward in crash tests) has been reduced by nearly four inches to 28 inches. In order to meet the new requirement, most forward-facing child restraints made after September 1, 1999, are equipped with a top tether strap. They also must meet the previous head excursion requirement without using the tether strap.
- ◆ Lower attachment hardware (a hook, buckle, or other type of connector) is required on new child restraints made since September 1, 2002, and is available on many models made before then. Webbing-based attachments must be adjustable.

Child Restraint Exceptions:

- ◆ Belt-positioning boosters, car beds, and harnesses are not required to have a tether strap or lower attachment hardware. However, lower attachment hardware is required on combination seats (forward-facing restraints with a removable harness that convert to boosters).
- ◆ Rear-facing child restraints are not required to have a tether strap. If a rear-facing restraint has a detachable base, only the base must have lower attachment hardware.

***LATCH (Lower Anchors and Tethers for Children)**

SafetyBeltSafe U.S.A. P.O. Box 553, Altadena, CA 91003 www.carseat.org
310/222-6860, 800/745-SAFE (English) 310/222-6862, 800/747-SANO (Spanish)

This document was developed by SafetyBeltSafe U.S.A. and may be reproduced in its entirety.
Important: Call to check if there is a more recent version before reproducing this document.

#622 (9-10-11)

Web Sites for Child Passenger Safety

National Highway Traffic Safety Administration Child Passenger Safety Site

<http://www.safercar.gov/parents/Car-Seat-Safety.htm>

- Child Safety Seat Inspection Station Locator
- Child Safety Seat Recall List
- Child Passenger Safety Contact Locator
- Child Safety Seat Registration Form

Recall List

<http://www-odi.nhtsa.dot.gov/recalls/childseat.cfm>

NHTSA Car Seat Ease of Use Ratings

<http://www.safercar.gov/parents/Car-Seat-Ratings-Ease-Of-Use.htm>

Safe Kids Worldwide

<http://cert.safekids.org>

- Information on the National Child Passenger Safety Certification Training Program
- Child Passenger Safety Technician search feature “Find a Tech”

Guidelines for the Safe Transportation of Pre-school Age Children in School Buses

<http://www.nhtsa.dot.gov/people/injury/buses/Guide1999/prekfinal.htm>

Proper Use of Child Restraint Systems in School Buses

- How to install handbook with pictures

<http://www.nhtsa.dot.gov/people/injury/buses/busseatbelt/index.html>

Choosing the Correct School Bus for Transporting Pre-school Age Children

- Very helpful when ordering school buses

http://www.nhtsa.dot.gov/people/injury/buses/choosing_schoolbus/pre-school-bus_01.html

School Bus Crashworthiness Research

<http://www.nhtsa.gov/Research/Crashworthiness/School+Bus+Crashworthiness+Research>

- Information regarding lap belts on school buses

Child Restraint Re-use after Minor Crash (NHTSA)

<http://www.nhtsa.dot.gov/people/injury/childps/ChildRestraints/ReUse/index.htm>

Safe Ride News

<http://www.saferideneews.com> look under Safety Topics for School Bus Safety

Ride Safe Website

<http://www.travelsafer.org>

- Wheelchair brochure

Safety Belt Safe U.S.A.

<http://www.carseat.org>

- CD of Child Restraint Manufacturers’ Instructions with Summary Sheets

American Academy of Pediatrics

<http://www.aap.org>

- Transportation-related policies

Automotive Safety Program/National Center for the Safe Transportation of Children with Special Healthcare Needs

<http://www.preventinjury.org>

- Information on transporting children with special healthcare needs

National Highway Traffic Safety Administration

<http://www.nhtsa.gov>

- Primary NHTSA website
- Laws and regulations

Cleaning and Maintenance of Child Safety Restraint Systems (CSRS)

With regular use, all CSRS become soiled and must be properly cleaned before returning them to your inventory for future use. The most practical advice for the care and maintenance of a CSRS begins with the CSRS instructions. **Always follow the CSRS manufacturer's cleaning instructions.** Here are some additional tips to make the process more manageable.



Tips and Techniques for the Proper Care and Maintenance of Child Safety Restraint Systems

- Read the CSRS instructions and follow the step-by-step directions for disassembling and re-assembling all of the parts.
- Brush or vacuum the padding.
- Remove the harness and padding being careful to remember how they will need to be re-attached.
- Replace the padding if it is torn or too soiled. Follow the washing instructions for the padding. Many pads may be machine washable on a gentle cycle. Read and follow the manufacturer's instructions. Never use dry cleaning solution on the padding.
- Replace the harness if it is frayed or heavily soiled. The harness may be spot cleaned or surface cleaned with a mild soap. Do not immerse totally in water unless directed by the CSRS instructions.

- Wipe the plastic shell with a damp cloth or sponge and a mild soap. Never use bleach, harsh chemicals or household detergents. They can weaken the plastic.
- Avoid wetting the labels.
- Never place the shell under extremely high temperatures. This will cause deformation and deterioration of the plastic.
- The buckle may be cleaned with a damp cloth. Do not lubricate or immerse the buckle in water.
- When all of the parts are cleaned and dried, reassemble the CSRS following the manufacturer's instructions.

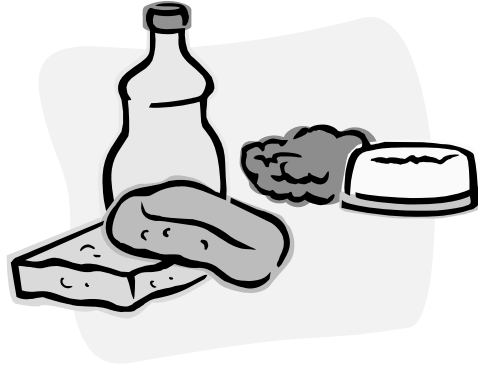

Lifespan of a CSRS

- Follow the manufacturer's direction as to when the CSRS need to be replaced. The lifespan of CSRS vary by manufacture. When in doubt contact the manufacturer.
- If the CSRS has any broken or missing parts that cannot be replaced or if the CSRS has been recalled, contact the manufacturer to determine if the seat should be repaired or destroyed.
- Read and follow the manufacturer's instructions if the CSRS has been involved in a crash.

Additional Information

For additional information on the proper care and maintenance of CSRS, contact the manufacturer.



SAMPLE

Child Passenger Safety Log

Name of School District _____

Address of School District _____

Name of Contractor _____

Address of Contractor _____

Vehicle Type _____

Vehicle License # _____

Vehicle Number _____

Type of Child Restraint: Circle one

Infant Convertible Forward-Facing Booster Vest Special Needs Seat

Manufacturer of Child Restraint _____

Make and Model Number _____

Date of Manufacture _____

Date Purchased _____

SAMPLE

CARE and MAINTENANCE

Recall List checked:

Dates _____

Recalled: Circle one YES NO

Recall Repaired: Circle one YES NO

Parts Replaced Circle one YES NO

List Replacement Parts and Date of Replacement _____

Copy of Manufacturer's instructions _____

Vehicle involved in crash: Circle one YES NO

Child Restraint involved in crash: Circle one YES NO

Child Restraint replaced: Circle one YES NO

Reason _____

Print Name _____

Signature _____

Re-Use of Child Restraint Systems In School Buses After Minor Crashes



NHTSA Position

- NHTSA recommends that child restraint systems (CRSs) be replaced following a moderate or severe crash in order to ensure a continued high level of crash protection for child passengers.
- NHTSA recommends that CRSs on school buses do not automatically need to be replaced following a minor crash.
- Minor crashes are those that meet ALL of the following criteria:
 - The school bus was able to be driven away from the crash site;
 - The occupant space inside the school bus near the CRSs was undamaged;
 - There were no injuries to any children in CRSs, or serious injury to any other school bus occupant;
 - The air bags (if present) did not deploy; AND
 - There is no visible damage to the CRSs.

Clarifying the need for child seat replacement will reduce the number of children unnecessarily riding without a CRS while a replacement seat is being acquired, and the number of children who will have to ride without a child seat if a seat were discarded and not replaced. The clarification will also reduce the financial burden of unnecessary replacement.

Background

- Recent studies demonstrate that child safety seats can withstand minor crash impacts without any documented degradation in subsequent performance.
- The Insurance Corporation of British Columbia (ICBC) subjected nine new and used child seats restraining 3-year-old-child dummies to a series of 50 consecutive 15 km/h sled tests into a 40 percent offset barrier. Three seats were inspected visually; no damage was apparent as a result of the impacts. Three seats underwent x-ray inspection; no damage was detected. Three seats were tested in accordance with Canadian Federal standards (CMVSS 213) and were found to be in compliance with all standards.
- ICBC performed four vehicle crash tests at 48 and 64 km/h, with two child seats restraining 3-year-old-child dummies in each vehicle. Each seat was subjected to multiple impacts and visually inspected. Defects were noted and the seats were re-tested. Seats always performed as well in subsequent tests as they did in the first test.
- The Insurance Institute for Highway Safety (IIHS) performed 30-mph vehicle crash tests with dummies from six-month-old-child to three-year-old-child types in a variety of child restraint systems (CRSs). Most seats sustained minor damage (e.g., frayed webbing, small cracks in the hard plastic shell, strain-whitening on the plastic shell or chest clip) but all dummies remained well secured by the restraints. Four of the damaged seats were subjected to three additional 30-mph crash tests. Although additional minor damage was observed in subsequent tests, the seats met all Federal standards.
- The agency searched for, but was unable to find, any cases in which a child safety seats were damaged in a minor crash (as defined in **NHTSA Position**).

Note:

The agency is committed to maintaining policies that are science-based and data-driven. Stakeholders with data that address post-crash re-use of child safety seats are encouraged to provide this information to the agency.

**CHILD SAFETY SEAT REGISTRATION FORM
FOR YOUR CHILD'S CONTINUED SAFETY**

Although child safety seats undergo testing and evaluation by the manufacturer and must also meet the requirements of Federal Motor Vehicle Safety Standard No. 213; Child restraint systems, it is possible that your child seat could be recalled.

All child seats come with a registration form so that owners can provide their names and addresses to the manufacturer. In the event of a recall manufacturers are required to notify all registered owners by first class mail that their child seat is included in the recall. Therefore, it is very important that the manufacturer of your child seat has your current mailing address, and all of the information necessary to properly identify your child seat.

The National Highway Traffic Safety Administration (NHTSA) encourages owners of child safety seats to **fill out the manufacturer's registration form attached to the child safety seat and send it directly to the manufacturer.** However, if you would like NHTSA to forward your registration information to the manufacturer, please provide all of the information requested on the lower half of this form, sign it and mail or fax (202-366-8546) it to: U.S. Department of Transportation, National Highway Traffic Safety Administration, Office of Defects Investigation, Correspondence Research Division (NVS-216), 1200 New Jersey Avenue, SE, Washington, DC 20590.

If you have any questions, or need help with any child seat, please call the U.S. Department of Transportation's toll-free Vehicle Safety Hotline at 1-888-327-4236 or visit our Website at www.nhtsa.dot.gov.

E-mail: _____

Name: _____

Address: _____



City: _____ State: _____ Zip Code: _____

Child Seat Manufacturer: _____

Model Number: _____ Manufacture Date: _____

I AUTHORIZE NHTSA TO PROVIDE A COPY OF THIS FORM TO THE CHILD SEAT MANUFACTURER IDENTIFIED ABOVE

(SIGNATURE REQUIRED): _____

 <p>United States Department of Transportation</p>	<p>AUTO SAFETY HOTLINE CHILD SAFETY SEAT QUESTIONNAIRE</p>
<p>National Highway Traffic Safety Administration</p>	<p>NATIONWIDE 1-800-424-9393  DC METRO AREA (202) 366-0213 </p>

To complete this information online go to:

<http://www.nhtsa.gov/cars/problems/childseat/childseat.cfm>

Form Approved: O.M.B. No. 2127-0008

Please provide your name, address, and phone number, as well as specific details about your child safety seat and the problems you encountered with it. We would like to have a telephone number where you can be reached or where we can leave a message. This is necessary to obtain more detailed information when required for our investigative efforts. You may want to have your child safety seat handy as you proceed through the several screens of the questionnaire. Required information is marked with *.

OWNER INFORMATION

* First Name: MI:

* Last Name:

* Address 1:

Address 2:

* City: * State: * Zip:

* Home Phone: - -

Work Phone: - - Ext:

The Privacy Act prevents release of owner information without prior authorization. In the absence of an authorization, NHTSA WILL NOT provide your name and address to the vehicle manufacturer.

* Do you authorize NHTSA to provide a copy of this information to the manufacturer of your child safety seat?

CHILD INFORMATION

Age:

Height/Length:

Weight:

Any Special Information:

CHILD SAFETY SEAT INFORMATION

*** Manufacturer:**

Date Manufactured:

Model Number and Name:

Type of Child Safety Seat

- Infant
- Booster
- Integrated
- Convertible
- Other

Safety Belt System Used

- Lap Shoulder
- Both

Child Seat Location

- Front
- Rear
- Right
- Left
- Center

Purchased From:

City State

Failed Part Name (Describe failure below)

Seat Was:

- Purchased New Used
- Obtained through loaner program
- Gift
- Borrowed / /

Failed Part:

- Base
- Frame
- Other
- Harness/Straps
- Material Padding
- Shield
- Buckle/Latch

VEHICLE INFORMATION

Make of Vehicle:

Model of Vehicle:

Year of Vehicle:

INCIDENT INFORMATION (If applicable)

Crash?

- Yes
- No

Police Report Filed

- Yes
- No

Number of Injured**Number of Fatalities****DESCRIBE INCIDENT/FAILURE IN DETAIL (Please explain how the Child Seat Failed)**[Proceed to Confirm Information](#)[Help](#)

The Privacy Act of 1974 - Public Law 93-579, As Amended: *This information is requested pursuant to the authority vested in the National Highway Traffic Safety Act and subsequent amendments. You are under no obligation to respond to this questionnaire. Your response maybe used to assist the NHTSA in determining whether a manufacturer should take appropriate action to correct a safety defect. If the NHTSA proceeds with administration enforcement or litigation against a manufacturer, your response, or statistical summary thereof, may be used in support of the agency's action.*

[NHTSA's Full Privacy Statement](#)



[Send mail to the Web Master](#)



Technical Report—Child Passenger Safety

abstract

FREE

Despite significant reductions in the number of children killed in motor vehicle crashes over the past decade, crashes continue to be the leading cause of death for children 4 years and older. Therefore, the American Academy of Pediatrics continues to recommend inclusion of child passenger safety anticipatory guidance at every health-supervision visit. This technical report provides a summary of the evidence in support of 5 recommendations for best practices to optimize safety in passenger vehicles for children from birth through adolescence that all pediatricians should know and promote in their routine practice. These recommendations are presented in the revised policy statement on child passenger safety in the form of an algorithm that is intended to facilitate their implementation by pediatricians with their patients and families. The algorithm is designed to cover the majority of situations that pediatricians will encounter in practice. In addition, a summary of evidence on a number of additional issues that affect the safety of children in motor vehicles, including the proper use and installation of child restraints, exposure to air bags, travel in pickup trucks, children left in or around vehicles, and the importance of restraint laws, is provided. Finally, this technical report provides pediatricians with a number of resources for additional information to use when providing anticipatory guidance to families. *Pediatrics* 2011;127:e1050–e1066

INTRODUCTION: MAGNITUDE OF THE PROBLEM OF MOTOR VEHICLE CRASHES

Motor vehicle crashes represent the leading cause of death for children and youth older than 3 years in the United States.¹ Each year, more than 5000 children and adolescents under the age of 21 years die in crashes, which represents approximately 15% of people killed each year in crashes.² Fatalities represent only the tip of the motor vehicle crash problem for children and youth. For every fatality, approximately 18 children are hospitalized and more than 400 receive medical treatment for injuries sustained in a crash.¹ Current estimates of injuries and fatalities are updated annually and can be found in the Centers for Disease Control and Prevention Web-based Injury Statistics Query and Reporting System at www.cdc.gov/injury/wisqars.

In the United States, motor vehicle traffic-related mortality rates are highest for black and American Indian/Alaskan Native children, lowest among Asian/Pacific Islander children, and intermediate for Hispanic and white children.³ Examining trends over a 20-year period through 2003 reveals significantly declining rates for child occupant deaths among all race and ethnic groups examined. However, among infants (aged 0–12 months), improvements in mortality rates among black children have slowed more recently. Occupant mortality rates among

Dennis R. Durbin, MD, MSCE, COMMITTEE ON INJURY, VIOLENCE, AND POISON PREVENTION

KEY WORDS

car safety seat, booster seat, child restraint system, air bag, child passenger safety, motor vehicle crash

ABBREVIATIONS

NHTSA—National Highway Traffic Safety Administration
CSS—car safety seat
AAP—American Academy of Pediatrics
LATCH—lower anchors and tethers for children
OR—odds ratio
CI—confidence interval
FARS—Fatality Analysis Reporting System
RR—relative risk
FMVSS—Federal Motor Vehicle Safety Standard
FAA—Federal Aviation Administration

This document is copyrighted and is property of the American Academy of Pediatrics and its Board of Directors. All authors have filed conflict of interest statements with the American Academy of Pediatrics. Any conflicts have been resolved through a process approved by the Board of Directors. The American Academy of Pediatrics has neither solicited nor accepted any commercial involvement in the development of the content of this publication.

The guidance in this report does not indicate an exclusive course of treatment or serve as a standard of medical care. Variations, taking into account individual circumstances, may be appropriate.

www.pediatrics.org/cgi/doi/10.1542/peds.2011-0215

doi:10.1542/peds.2011-0215

All policy statements from the American Academy of Pediatrics automatically expire 5 years after publication unless reaffirmed, revised, or retired at or before that time.

PEDIATRICS (ISSN Numbers: Print, 0031-4005; Online, 1098-4275).

Copyright © 2011 by the American Academy of Pediatrics

children 1 to 4 years of age showed a tendency toward increased mortality in black, Hispanic, and American Indian/Alaskan Native children. Although there were significant declines in total motor vehicle mortality rates across all racial groups, improvement in occupant injury was greater for white children, and disparities actually widened for both black and American Indian/Alaskan Native children compared with white children.

The racial/ethnic disparities in motor vehicle occupant death rates are likely explained in large part by lower use of restraints, including child restraint systems, by people of racial minorities. Seat belt and child restraint use among black adults and children are lower than the national average.^{4,5} Similarly, seat belt use among Hispanic (85%) and non-Hispanic black (80%) adults traveling with children was lower than that for white (96%) adults traveling with children.⁶ The reasons for these disparities in restraint use are not completely known but may be related to a lack of knowledge as well as a lack of culturally appropriate messages from generalized public education intervention programs.⁷ More culturally sensitive intervention programs designed to increase child restraint use among minority populations have resulted in significant increases in restraint use among target populations.⁸

Through the early 1990s, child occupant fatality rates remained relatively stagnant at approximately 3.5 deaths per 100 000 population.⁹ Beginning in 1995, when children killed by deploying passenger air bags were first reported clinically, attention began to focus on the unique needs of children in automotive safety. Subsequently, in the United States, the number of motor vehicle fatalities and serious injuries has been reduced through a combination of increased attention to age-

appropriate restraint use and rear seating position^{10–15} as well as enhanced child restraint laws and enforcement of these laws.^{16,17} In the 10 years from 1999 to 2008, the number of children younger than 15 years who died in motor vehicle crashes in the United States declined by 45%.² Annual updates on the number of children killed in motor vehicle crashes can be obtained from the National Highway Traffic Safety Administration (NHTSA) at www.fars.nhtsa.dot.gov/Main/index.aspx.

Although significant progress has been made in reducing the number of children killed in crashes, the exposure of children to motor vehicle travel and, thus, to potential crashes is great. Children younger than 16 years travel nearly as much as adults (average of 3.4 trips per day and 45 to 50 minutes/day spent in a vehicle), which emphasizes the importance of age-appropriate restraint on every trip.¹⁸

THE IMPORTANCE OF AGE-APPROPRIATE RESTRAINT USE

Mechanism of Action of Restraint Systems

Restraint systems are designed to reduce risk of ejection during a crash, better distribute the energy load of the crash through structurally stronger bones rather than soft tissues, limit the crash forces experienced by the vehicle occupant by prolonging the time of deceleration, and limit the contact of the occupant with interior vehicle structures. Optimal performance of restraint systems depends on an adequate fit between the restraint system and the occupant at the time of the crash. Restraint systems can be generally categorized as vehicle restraints—air bags and seat belts—or add-on restraints specifically made for children—child restraint systems. Child restraint systems include infant-only car safety seats (CSSs), convert-

ible and combination CSSs, integrated seats, travel vests, and belt-positioning booster seats. A description of each type of restraint is provided below as well as in Table 1 of the accompanying policy statement.¹⁹

Age-Specific Prevalence of Restraint Use

In large part because of the increased attention paid to the needs of children in motor vehicle safety beginning in the mid-1990s, large increases in restraint use (including CSSs and booster seats) by children have been observed over the past decade. Data from the National Occupant Protection Use Survey and the National Survey of the Use of Booster Seats indicate that restraint use for children in the United States in 2008 stood at 99% among infants younger than 1 year, 92% among 1- to 3-year-olds, and 89% among 4- to 7-year-olds.²⁰ Restraint use for children driven by a belted driver was significantly higher (92%) than for those driven by an unbelted driver (54%). It is important to note that although child restraint use is high among the youngest children, improper use of the restraint may limit the effectiveness of the system. Among children either younger than 1 year or who weighed less than 20 lb, a group that has traditionally been recommended to ride in a rear-facing CSS, 21% were not compliant with these recommendations.²¹ Similarly, although overall restraint use among older children is relatively high, nearly half of children 12 years and younger who are under 54 inches in height are not using a CSS or booster seat, which is their recommended form of optimal restraint.²¹ Although the prevalence of use according to race and ethnicity varied somewhat among age groups, use rates tended to be higher among white and Asian non-Hispanic children (at least 90% for all age groups) and lower among black non-Hispanic children

(ranging from 72% for 8- to 12-year-olds to 94% for infants younger than 1 year).²² It should be noted that child restraint use among black children 4 to 7 years of age increased from 73% in 2007 to 84% in 2008.

Among children 8 years and younger in crashes, overall reported use of child restraint systems has increased nearly threefold since 1999 to 80% of children in a large sample of children in crashes by 2007.²³ The largest relative increase in child restraint use among children in crashes was among 6- to 8-year-olds, yet 57% of these children continued to be inappropriately restrained in 2007. Forward-facing CSSs were primarily used by children 3 years and younger, whereas belt-positioning booster seats have become the most common restraints for 4- to 5-year-olds.²⁴

Pediatric obesity has become a major public health concern in the United States as the prevalence of being overweight among children tripled over the past 2 decades.²⁵ Currently, 34% of children are categorized as being “overweight” (BMI \geq 95th percentile) or “at risk for overweight” (BMI \geq 85th to $<$ 95th percentile).²⁶ Childhood obesity has significant implications for child passenger safety, because young children who are overweight may not fit properly in CSSs or booster seats that would otherwise be appropriate for their age.²⁷ It is fortunate that, over the past several years, increasing numbers of CSSs and booster seats with higher weight and height limits have been introduced into the market in response to this challenge. Among currently available products listed in the American Academy of Pediatrics (AAP) pamphlet “2011 Car Safety Seats: A Guide for Families” (available at www.healthychildren.org/carseatlist), nearly half (14 of 29) of infant-only seats can accommodate children to 30 lb or more, which represents at least

the 75th percentile for girls and boys at 24 months of age. Nearly all (30 of 35) currently available convertible CSSs can accommodate children to 35 lb or more when used rear-facing, a weight that exceeds the 95th percentile for boys and girls at 24 months of age. Similarly, for children 2 to 8 years of age, 34 of 53 currently available forward-facing seats used with a harness can accommodate children to at least 50 lb, which exceeds the 95th percentile for boys and girls younger than 5 years. Therefore, there are sufficient products available to consumers to accommodate larger children in the correct restraint. Limited data exist on the risk of injury to overweight children in motor vehicle crashes but suggest that overweight children may be at an increased risk of particular types of injuries, particularly lower-extremity fractures, compared with children of normal weight.^{28–30} Further research is needed to establish motor vehicle safety as yet another public health burden imposed by childhood obesity and to ensure that overweight children are properly protected in motor vehicles.

Seat belt use among all front-seat occupants (drivers and front passenger-seat occupants) in the United States increased to 84% in 2009.³¹ Among older children, restraint use in any seating location in the vehicle in 2008 was 85% among 8- to 12-year-olds and 83% among 13- to 15-year-olds.^{6,20} Seat belt use anywhere in the vehicle among 13- to 15-year-olds varied according to race and ethnicity; white adolescents had higher seat belt use rates (89%) than either Hispanic (82%) or black non-Hispanic (46%) youth.

It is important to note that CSSs were designed as occupant safety devices in motor vehicles, not as general child seating devices. A recent study that used data from the National Electronic Injury Surveillance System operated by the US Consumer Product Safety

Commission estimated that more than 8000 infants younger than 1 year are evaluated in hospital emergency departments each year for car seat-related (non-motor vehicle crash) injuries suffered when the car seats were used improperly or for unintended purposes.³² The majority (85%) of injuries were related to falls, either infants falling out of car seats or car seats falling from elevated surfaces such as countertops and tables. Nearly half of the injuries occurred at home, and head and neck injuries accounted for 84% of the injuries to infants. Prolonged use of CSSs by young infants for positioning also contributes to the increased incidence of plagiocephaly, exacerbates gastroesophageal reflux, and increases risk of respiratory compromise.³³ Families should be encouraged to use CSSs only as occupant-protection devices for travel as they were intended.

Installation of Child Restraint Systems

CSSs must be installed tightly to derive the optimum benefit of both the crash-worthiness of the vehicle (eg, crumple zones that dissipate the energy of the crash and prolong the time of deceleration of the vehicle) and the design of the seat itself. As a general rule, if a CSS can be moved more than 1 inch from side to side or front to back when grasped at the bottom of the seat near the belt or lower anchors and tethers for children (LATCH) attachment points, it is not installed tightly enough. Improper installation of a CSS may result in an increased likelihood of excessive movement of the child in the event of a crash, thus increasing the child’s risk of injury.

The most recent estimates of CSS misuse are derived from an observational study of more than 5000 children in which 72.6% of CSSs were observed to have some form of misuse.^{34,35} The

most common critical misuses were loose harness straps and a loose attachment of the CSS to the vehicle when using the seat belt. Results of several studies have indicated that misused CSSs may increase a child's risk of serious injury in a crash.^{13,14,36,37}

An issue specific to installing rear-facing CSSs relates to the recline angle of the seat. Proper installation results in a semireclined angle of approximately 45°, which enables the infant's head to lie against the back of the CSS, as opposed to potentially falling forward, which compromises the infant's airway, if the seat is angled too upright. Preterm infants are particularly vulnerable to an increased risk of oxygen desaturation, apnea, and/or bradycardia, especially when placed in a semireclined position in CSSs.^{38–41} Therefore, CSS monitoring in the infant's own CSS before discharge from the hospital should be considered for any infant who was less than 37 weeks' gestation at birth to determine if the infant is physiologically mature and has stable cardiorespiratory function. More specific information on car seat testing of preterm newborn infants and recommendations based on results of testing are available in an AAP clinical report on the subject.³⁵

A relatively new way by which CSSs can be installed in passenger vehicles, known as LATCH, was designed to reduce the difficulty associated with installing CSSs. This system uses dedicated attachment points in the vehicle rather than using the vehicle seat belt for CSS installation. All vehicles and child restraints manufactured and sold in the United States after September 2002 are required to have this anchoring system. For rear-facing CSSs, there are 2 points of attachment at the base of the CSS. For forward-facing CSSs, a third dedicated attachment point near the top of the CSS is used for

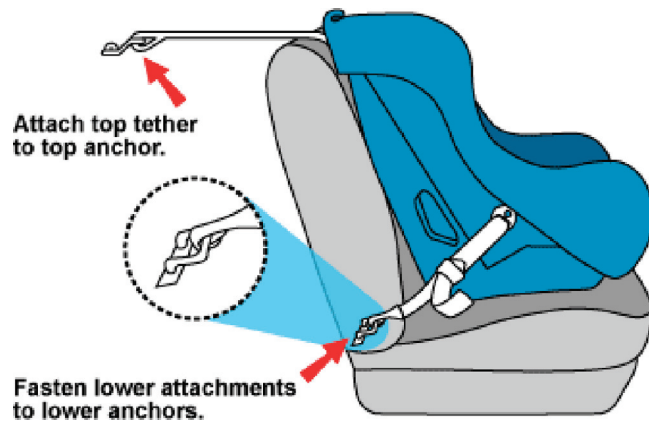

FIGURE 1
Schematic of the LATCH system.

a top tether to attach to a separate anchor point in the vehicle (see Fig 1).

Previous research has evaluated the performance of LATCH (or its European counterpart, ISOFIX) in laboratory sled-test environments^{42–44} and demonstrated improved kinematics and reduced injury measures on crash test dummies, in particular with use of the top tether, when compared with using a seat belt to attach the CSS. To date, there are no real-world data from evaluations of the performance of LATCH, although its theoretical advantages in ensuring proper installation suggest that families should use it when available.

Arbogast and Jermakian have reviewed cases of CSSs attached by using LATCH and illustrated examples of LATCH misuse.⁴⁵ In 2005, a large-scale observation study that examined LATCH use and misuse in the United States was conducted at 66 sites across 7 states.⁴⁶ The study results indicated that many parents who purchased newer vehicles did not update their CSS to take advantage of the available LATCH attachment system. Approximately one-fifth of CSSs in vehicles equipped with LATCH did not have tether straps, and one-sixth did not have lower attachments. Even when their CSSs were LATCH equipped, approximately one-third of the drivers with LATCH-equipped vehicles stated

that they could not use LATCH because there were no anchors in their vehicles. Much of the nonuse of lower anchors in this study related to the fact that the vehicle safety belt was the only method available in the center rear-seating position for installing a CSS. The rear seats of most passenger vehicles typically are equipped with lower LATCH anchors only in the outboard seating positions. When parents had experience attaching CSSs by using the safety belt and LATCH system, three-quarters reported a preference for LATCH, because they found it easier to use and obtained a tighter fit, and they felt that the child was more secure.

EVIDENCE FOR BEST-PRACTICE RECOMMENDATIONS

The following section of this technical report will provide a summary of the evidence in support of each of the best-practice recommendations included in the accompanying policy statement.

Children with certain physical and behavioral conditions may require specialized restraint systems and other considerations. Relevant conditions may include prematurity, cerebral palsy, the presence of a tracheostomy, muscle tone abnormalities, skeletal abnormalities, and certain behavioral or emotional conditions as well as

temporary conditions such as fractures that require spica casts. Therefore, the AAP has developed a separate policy statement that reviews important considerations for transporting children with special health care needs and provides current guidelines for the protection of children with specific health care needs, including those transported in wheelchairs.⁴⁷

1. Best-Practice Recommendation: All Infants and Toddlers Should Ride in a Rear-Facing CSS Until They Are 2 Years of Age or Until They Reach the Highest Weight or Height Allowed by the Manufacturer of Their CSS

This best practice results from the need to support the young child's posterior torso, neck, head, and pelvis and to distribute crash forces over the entire body. Developmental considerations, including incomplete vertebral ossification, more horizontally oriented spinal facet joints, and excessive ligamentous laxity put young children at risk of head and spinal cord injury. Rear-facing CSSs address this risk by supporting the child's head and preventing the relatively large head from moving independently of the proportionately smaller neck.

In the United States, although the majority of children use rear-facing CSSs during the first year of life, 21% of infants who are either younger than 1 year or weigh less than 20 lb have been turned forward-facing.²¹ In Sweden, many children remain rear-facing up to the age of 4 years and transition directly from the rear-facing CSS to a booster seat. Swedish researchers have reported that rear-facing CSSs reduce the risk of significant injuries (those with an Abbreviated Injury Scale score of ≥ 2) by 90% relative to unrestrained children, which reinforces their policy of children remaining in a rear-facing CSS up to the age of 4 years.^{48,49}

Henry et al⁵⁰ reviewed US crash data to calculate the relative effectiveness of rear-facing CSSs compared with forward-facing CSSs for children 0 through 23 months of age in crashes from 1988 to 2003. The authors reported that children in forward-facing CSSs were significantly more likely to be seriously injured when compared with children restrained in rear-facing CSSs in all crash types (odds ratio [OR]: 1.76 [95% confidence interval [CI]: 1.40–2.20]). When considering frontal crashes alone, children in forward-facing CSSs were more likely to be seriously injured, although this finding was not statistically significant (OR: 1.23 [95% CI: 0.95–1.59]). In side-impact crashes, however, children in forward-facing CSSs were much more likely to be injured (OR: 5.53 [95% CI: 3.74–8.18]). When children 12 to 23 months of age were analyzed separately, those who were restrained in forward-facing CSSs were also more likely to be seriously injured (OR: 5.32 [95% CI: 3.43–8.24]). These authors concluded that for children through 23 months of age, rear-facing CSSs provided optimal protection. The lack of meaningful numbers of children 24 months or older in rear-facing CSSs in US databases has prevented extension of these analyses to even older age groups of children, such as those studied in Sweden.

2. Best-Practice Recommendation: All Children 2 Years or Older, or Those Younger Than 2 Years Who Have Outgrown the Rear-Facing Weight or Height Limit for Their CSS, Should Use a Forward-Facing CSS With a Harness for as Long as Possible, up to the Highest Weight or Height Allowed by the Manufacturer of Their CSS

The recommendation for forward-facing CSSs has been based, in part, on an analysis by Kahane⁵¹ of laboratory sled tests, observational studies, and

police-reported crash data from the early 1980s that estimated that correctly used forward-facing CSSs reduce the risk of death and injury by approximately 71% compared with unrestrained children. The engineering tests documented the biomechanical benefits of the CSS in spreading the crash forces over the shoulders and hips and controlling the excursion of the head during a crash. Kahane further estimated the effectiveness of a partially misused CSS as providing a 45% reduction in risk of fatality and serious injury. Using Fatality Analysis Reporting System (FARS) data from 1988 to 1994, NHTSA found that, among children between 1 and 4 years of age in passenger cars, those in forward-facing CSSs had a 54% reduction in risk of death compared with unrestrained children.⁵² Given the currently high rates of restraint use among children in the United States, it is no longer meaningful to quote effectiveness estimates in comparison to unrestrained children.

Estimates of the effectiveness of forward-facing CSSs in comparison with children using seat belts, on the basis of real-world crash data, vary depending on the source of data used, the time period studied, and the analytical approach taken. Estimating effectiveness of child restraint systems through analysis of crash databases is challenging because of the association between how passengers are restrained in a given crash and whether that crash will be in a specific database. For example, the FARS, operated by the NHTSA, is a census of vehicle crashes in the United States in which at least 1 person died. The FARS has a sufficient number of outcomes of fatal child injuries for analyses but has a biased selection of crashes in that inclusion of crashes is associated with the outcome of interest (ie, mortality). Several different analytic techniques, de-

scribed hereafter, have been developed to minimize the effects of this bias.

The results of most studies to date have indicated that forward-facing CSSs are effective at preventing nonfatal injuries when compared with seat belts; effectiveness estimates have ranged from 71% to 82% reduction in serious injury risk.^{13,53} Elliott et al¹⁴ compared the effectiveness of child restraints to seat belts in preventing fatal injuries to 2- to 6-year-old children in crashes by combining data from the FARS with data from the National Automotive Sampling System–Crashworthiness Data System. The combined data set, in theory, overcame several of the known limitations of using either data source alone. Compared with seat belts, child restraints, when not seriously misused (eg, unattached restraint, child restraint system harness not used) were associated with a 28% reduction in risk of death (relative risk [RR]: 0.72 [95% CI: 0.54–0.97]) after adjusting for seating position, vehicle type, model year, driver and passenger ages, and driver survival status. When including cases of serious misuse, the effectiveness estimate was slightly lower (21%) and not statistically significant (RR: 0.79 [95% CI: 0.59–1.05]).

In a controversial analysis, Levitt⁵⁴ used FARS data from 1975 to 2003 and, by various methods, directly compared the mortality rates for child restraints and for seat belts for children aged 2 to 6 years and could not demonstrate a difference in effectiveness. Levitt restricted the FARS data set to 2-vehicle crashes in which someone in the other vehicle (ie, the vehicle without the index child occupant) died, under the assumption that the distribution of restraint use among children in potentially fatal crashes is independent of whether someone in the other vehicle dies, after adjusting for various crash-related characteristics. In a subsequent study in which a marginal-

structural-model-type estimator was used in an attempt to explore the relationship between various biases inherent in data sources and the estimates of CSS restraint effectiveness, Elliott et al⁵⁵ suggested a 17% reduction in fatality risk for children 2 through 6 years of age in child restraint systems relative to seat belts. This reduction is estimated at 22% when severe misuse of the restraint is excluded.

3. Best-Practice Recommendation: All Children Whose Weight or Height Is Above the Forward-Facing Limit for Their CSS Should Use a Belt-Positioning Booster Seat Until the Vehicle Lap-and-Shoulder Seat Belt Fits Properly, Typically When They Have Reached 4 Feet 9 Inches in Height and Are Between 8 and 12 Years of Age

Children who have outgrown a forward-facing CSS (based on the height or weight limit of the seat) should be restrained in belt-positioning booster seats by using the lap-and-shoulder belts in the back seat of a vehicle. Booster seats position the child so that the lap-and-shoulder belt fits properly. Correct fit of the belt is defined as follows:

- The shoulder belt lies across the middle of the chest and shoulder, not the neck or face.
- The lap belt is low across the hips and pelvis, not the abdomen.
- The child is tall enough to sit against the vehicle seat back with his or her knees bent without slouching and can stay in this position comfortably throughout the trip.

Although seat belt geometry varies from vehicle to vehicle depending on the depth of the seat bottom and placement of the upper and lower anchor points of the belt, most vehicle seat belts will not fit correctly until a child reaches approximately 4 feet 9 inches in height and is between 8 and 12 years

of age. This height threshold was derived from a study of 155 children 6 to 12 years of age who were assessed for the fit of the vehicle seat belt in 3 different types of vehicles in 1993.⁵⁶ The minimum height of a child who could fit properly in the vehicle seat belts was 148 cm (58 inches). It is important to note that this study is nearly 20 years old, and significant changes have been made to the vehicle fleet during this time.

Cases of serious cervical and lumbar spinal cord injury, as well as intraabdominal injuries, to children in motor vehicle crashes resulting from poorly fitting seat belts have been described for many years and are known as the “seat belt syndrome.”⁵⁷ First described by Kulowski and Rost in 1956,⁵⁸ the term “seat belt syndrome” was coined by Garrett and Braunstein in 1962⁵⁹ to describe a distinctive pattern of injuries associated with lap seat belts in serious crashes. Two predominant factors have been hypothesized to explain this constellation of injuries: the immaturity of the pediatric pelvis to properly anchor the lap portion of the belt and the tendency of children to scoot forward in the seat so that their knees bend at the edge of the vehicle seat. From this position, in a rapid deceleration, the belt can directly compress abdominal organs against the spinal column, and the child’s body may “jack-knife” around the belt, putting high tension forces on the lumbar spine, which may lead to distraction injuries of the posterior elements of the spine, such as Chance-type fractures.

Durbin et al¹² published results of the first real-world evaluation of the performance of booster seats compared with seat belts for young children. These authors determined that the risk of injury after adjusting for child, crash, driver, and vehicle characteristics was 59% lower for 4- to 7-year-olds in belt-positioning booster seats than those using only seat belts. Applying these results to Wisconsin state data

from 1998 to 2002, Corden⁶⁰ determined that there would be an approximate 57% reduction in deaths and hospitalizations if all 4- to 7-year-olds were in booster seats. A recent updated analysis of booster effectiveness in preventing nonfatal injuries was able to examine a greater percentage of older children using booster seats; 37% of the more recent study sample using booster seats were 6 to 8 years of age.²⁴ In this study, children 4 to 8 years of age using belt-positioning booster seats were 45% (95% CI: 4%–68%) less likely to sustain nonfatal injuries than children of similar ages using the vehicle seat belt. Among children restrained in belt-positioning booster seats, there was no detectable difference in the risk of injury between the children in backless versus high-back boosters.

Rice et al⁶¹ extended the data on booster seat performance by estimating the effectiveness of booster seats in reducing the risk of fatal injuries to children 4 to 8 years of age. Using a matched cohort analysis of data from the FARS, Rice et al determined that booster seats reduced the risk of fatal injuries by 67% for 4- to 5-year-olds and 55% for 6- to 8-year-olds compared with unrestrained adults and children. They also determined that seat belts alone reduced the risk of fatal injury by approximately 62% for 4- to 8-year-olds compared with unrestrained adults and children. They did not demonstrate a significant difference in fatality risk reduction for booster seats when compared with seat belts (RR: 0.92 [95% CI: 0.79–1.08]). The authors postulated that although booster seats, which improve seat belt fit, may reduce the risk of nonfatal injuries (some of which may be attributable to improperly fitting seat belts), they may not improve the likelihood that children will survive a severe crash with major occupant compartment intrusion or during rollovers. It may be that properly fit-

ting seat belts are no better than poorly fitting seat belts at preventing fatal injuries in these severe crashes.

Although most newer vehicles include lap-and-shoulder belts in all rear-seating positions, many older vehicles still in use may have only lap belts available in some seating positions, typically in the center of the rear seat. Laboratory tests have revealed increased head excursions when booster seats are used with lap belts compared with when only lap belts are used.^{62,63} Other research results have indicated that booster-aged children using only lap belts are likely to strike their heads on vehicle seat backs or other interior components in front of them, even without booster seats.^{64,65} Results of a recent study that used 2 real-world data sources suggested that children restrained in booster seats with lap belts had a lower injury risk when compared with children restrained in lap belts only, although the possibility of no difference could not be excluded.⁶⁶ For families faced with frequently transporting booster-aged children in lap-belt-only seating positions, there are other restraint options (eg, forward-facing GSSs with higher weight limits and safety vests) that, although typically more expensive than booster seats, are more likely to provide optimal protection if children ride regularly in these seating positions. It should be noted that the number of children in this scenario will decrease over time as vehicles equipped with lap-belt-only restraints in rear seats are phased out of the US vehicle fleet.

4. Best-Practice Recommendation: When Children Are Old Enough and Large Enough to Use the Vehicle Seat Belt Alone, They Should Always Use Lap-and-Shoulder Seat Belts for Optimal Protection

Lap-and-shoulder belts have been required in rear outboard positions of

vehicles since 1989. However, it was not until 2005 that lap-and-shoulder belts were required in the center rear-seat position. Many manufacturers introduced center rear lap-and-shoulder belts in advance of this requirement, and by model year 2001, most vehicles provided them as standard equipment.⁶⁷ Arbogast et al⁶⁸ determined that the presence of a shoulder belt reduced the risk of injury by 81% for children seated in the center rear in seat belts, and the primary benefit is seen in reductions in abdominal injuries. Parenteau et al⁶⁹ had previously documented a similar shift in the pattern of injury to children in lap-only belt restraints to lap-and-shoulder belts. Their study, however, examined the rear seat as a whole and did not separate the rear seating positions.

Using data from the FARS, the NHTSA has evaluated the performance of lap-and-shoulder belts in the rear rows and found them to be effective (compared with unrestrained occupants) in all crash directions for children and adult occupants 5 years and older. The estimated fatality reduction, compared with unrestrained occupants, was 77% in roll-over crashes, 42% in side impacts, 29% in frontal impacts, and 31% in rear impacts and other crashes.⁷⁰ Two studies have evaluated seat belt effectiveness specifically for children. Chipman et al,⁷¹ using a database of fatal crashes in Ontario, Canada, estimated that seat belts reduced the risk of serious injury or death by 40% for children 4 to 14 years of age. Data from Wisconsin suggested that 100% seat belt use by children 8 to 15 years of age (compared with current 72% use) would result in reductions of 45% and 32% for deaths and hospitalizations, respectively.⁶⁰

5. Best-Practice Recommendation: All Children Younger Than 13 Years Should Be Restrained in the Rear Seats of Vehicles for Optimal Protection

In large part because of the attention resulting from the tragedy of children killed by passenger air bags, significant declines in front seating of children in vehicles have occurred since the mid-1990s. By 2008, 95% of infants, 98% of children 1 to 3 years of age, and 88% of children 4 to 7 years of age rode in the rear seat.²⁰ These rates compare with rates of 85%, 90%, and 71%, respectively, in 2002, the first year from which these data were available from direct observation studies.⁷² It should be noted that rear seating does not seem to vary on the basis of whether there is a state law requiring children to ride in the rear. In 2008, 92% of children who lived in states in which such a law existed rode in the rear, versus 93% of children from states in which no such law exists.²⁰ Children using child restraint systems were more likely to sit in the rear ($\geq 93\%$) than were those in seat belts (89%) or riding unrestrained (84%). In a study of children involved in nonfatal crashes, children were more likely to be seated in the front if the vehicle was driven by a male or by someone other than the child's parent or if the vehicle was not equipped with a passenger air bag.⁷³ Among children younger than 4 years in CSSs who have been in crashes, there seems to be a preference for placing the CSS in the right outboard seating position in the rear row (41%) compared with the center rear (31%) or left outboard (28%),⁷⁴ which likely has to do with the increased ability for the driver to directly observe the child more easily when in the right outboard rear seating position.

Several studies have documented the benefits of rear seating for children. Estimates of the elevated risk of injury

for children in the front seat compared with children in the rear have ranged from 40% to 70% depending on the time period and characteristics of the group studied.^{10,75,76} The authors of 1 of these studies specifically noted that the beneficial effects of the rear seat were no longer seen for children 13 years and older.¹⁰ Thus, the AAP continues to recommend that all children younger than 13 years ride in the rear seat. It is interesting to note that the benefits of rear seating for child occupants extend to side impacts as well; children seated in the rear are 62% less likely to sustain an injury.⁷⁷ Not only is the overall risk higher, but the severity of injury is also greater in the front seat. An analysis of crashes identified through the Crash Injury Research and Engineering Network (CIREN) revealed that child occupants in the front seat sustained more severe injuries than those seated in the rear rows as measured by an injury severity score higher than 16.⁷⁸

Two recent studies specifically evaluated the potential incremental benefits of the center rear seating position compared with the rear outboard positions. Lund⁷⁹ used data from the National Automotive Sampling System—General Estimates System system from 1992 to 2000 to evaluate the effect of seating position on the risk of injury for children in child restraints. Lund reported that children in the center rear seat had a similar risk of injury to children in the outboard rear seats. In contrast, Kallan et al⁷⁴ used data from the Partners for Child Passenger Safety project, a large, child-focused crash-surveillance system, from 1998 to 2006 and found that children restrained in forward-facing CSSs and seated in the center rear had an injury risk 43% lower than similarly restrained children in either of the rear outboard positions (adjusted OR: 0.57 [95% CI: 0.38–0.86]). These con-

trasting findings are likely attributable to how injuries were defined in the 2 studies. Lund defined injury as any police-reported injury, which included those of a relatively minor nature. The threshold for injury was higher in the Kallan et al analysis, which included only injuries involving internal organs and fractures of the extremities.

CHILDREN AND AIR BAGS

In November 1995, an article in the *Morbidity and Mortality Weekly Report* of the Centers for Disease Control and Prevention described 8 deaths of child occupants involving air-bag deployment that were of special concern, because they involved low-speed crashes in which the children otherwise should have survived.⁸⁰ As passenger air bags diffused into the market, numerous case reports began appearing in the medical literature describing brain and skull injuries sustained by children in rear-facing CSSs and brain and cervical spine injuries sustained by older children who were often unrestrained or restrained in seat belts inappropriately for their age.^{81–85}

Several researchers reviewed case series of children exposed to deploying passenger air bags to elucidate the mechanisms of injury.^{86–90} For children killed in a rear-facing CSSs, the air bag typically deployed into the rear surface of the child restraint near the child's head and caused fatal skull and brain injuries. For older children who were either unrestrained or restrained in seat belts inappropriate for their age, braking before impact caused the child to pitch forward so that they were in the path of the air bag as it deployed. On deployment, the air bag caused a spectrum of injuries to the brain and cervical spine, including atlanto-occipital fractures, brainstem injuries, and diffuse axonal injury. Case series of other less serious injuries to child occupants associated with

air-bag deployment continue to appear in the literature, including injuries to the eye⁹¹ and upper extremities⁹² as well as respiratory and hearing problems related to the sound wave and cloud of fine particulate matter released during an air-bag deployment.⁹³

Several population-based estimates of the effects of air bags on young children in crashes have consistently indicated an increased risk of fatal and nonfatal injuries to both restrained and unrestrained child occupants.^{11,12,94–98} Exposure to passenger air bags increased the risk of both minor injuries, including facial and chest abrasions, and moderate and more serious injuries, particularly head injuries and upper-extremity fractures.

On the basis of this evidence, the NHTSA initiated a 2-pronged program of education and regulation in response to the initial reports of deaths and serious injuries to children from air bags. First, the NHTSA, joined by many national organizations including the AAP, recommended that all child passengers younger than 13 years sit in the rear seats of vehicles. Second, in 1997, the NHTSA enacted a substantial regulatory change to Federal Motor Vehicle Safety Standard (FMVSS) 208, the safety standard that governs the protection of motor vehicle occupants in frontal impact crashes. Because frontal air bags are designed to primarily protect occupants in frontal impact crashes, their performance is certified through FMVSS 208. The change provided automakers a choice in the type of test that could be used to certify frontal crash performance for unbelted adults.⁹⁹ This change in the standard resulted in the redesign of frontal air bags to reduce the force with which they deploy. These new air bags are often referred to as “second-generation air bags” and were generally present in all vehicles beginning with model year 1998.

Several studies have examined the effect of these design changes on child occupants in real-world crashes. Olson¹⁰⁰ found that second-generation air bags reduced the risk of death among right-front-seated children 6 to 12 years of age by 29% compared with no air bag. For children younger than 6 years, both first- and second-generation air bags increased the risk of death compared with no air bag; however, the increased risk of death was less for second-generation air bags (10%) compared with first-generation air bags (66%). Arbogast et al¹⁰¹ quantified the risk of serious nonfatal injuries in frontal crashes among belted children in the front seat of vehicles in which second- versus first-generation passenger air bags deployed. Serious injuries were reported in 14.9% in the first-generation group versus 9.9% in the second-generation group. In particular, children in the second-generation group sustained fewer head injuries, including concussions and other serious brain injuries, than in the first-generation group.

Braver et al¹⁰² examined federal crash data to determine the effect of second- versus first-generation air bags on the risk of fatal injuries to children in the right-front seat. Right-front passengers younger than 10 years in vehicles with second-generation air bags had statistically significant reductions in risk of dying in frontal collisions compared with children of similar ages in vehicles with first-generation air bags, including a 65% reduced risk among children 0 to 4 years of age (RR: 0.35 [95% CI: 0.21–0.60]). Nonsignificant decreases in risk of death were observed among children 10 to 14 years of age.

Kuppa et al¹⁰³ evaluated the influence of the air bag on the effectiveness of rear seating by using a double-pair comparison study of frontal impact

crashes identified in the FARS. Two pairs were analyzed: the first group consisted of fatal crashes in which a driver and front outboard seat passenger were present and at least 1 of them was killed; the second group consisted of fatal crashes in which a driver and a rear outboard seat passenger were present and at least 1 of them was killed. This analysis examined vehicles with and without a passenger air bag separately. For restrained children 5 years or younger, the presence of a passenger air bag increased the benefit, in terms of reduced fatalities, associated with rear seating. For restrained child occupants older than 8 years, the rear seat was still associated with a lower risk of death than the front, but its benefit was less in vehicles with a passenger air bag than in vehicles without a passenger air bag.

Air bags continue to undergo significant redesigns in an effort to optimize their effectiveness in serious crashes while minimizing their risk of adverse injuries in minor crashes. In 2001, additional revisions were made to FMVSS 208, which now requires the testing of air-bag systems for all sizes of occupants, including children. At this time, no studies have evaluated the benefits of these designs, often termed “certified advanced compliant air bags,” for child occupants.

There have been limited studies that have attempted to examine age-specific effects of air bags on risk of injury to children. Newgard and Lewis⁹⁷ used data from the National Automotive Sampling System–Crashworthiness Data System to evaluate specific cutoff points for age, height, and weight as effect modifiers of the association between the presence of a passenger air bag and serious injury among children involved in motor vehicle crashes. The time period studied (1995–2002) preceded the time when

second-generation air bags were generally available in the vehicle fleet. Newgard and Lewis found that children 0 to 14 years of age involved in frontal collisions seemed to be at increased risk of serious injury from air-bag presence (OR: 2.66 [95% CI: 0.23–30.9]) and deployment (OR: 6.13 [95% CI: 0.30–126]), although these values did not reach statistical significance. Among children 15 to 18 years of age involved in frontal collisions, there was a protective effect on injury from both air-bag presence (OR: 0.19 [95% CI: 0.05–0.75]) and deployment (OR: 0.31 [95% CI: 0.09–0.99]). A similar analysis has not been replicated to determine if different age cutoffs might be identified with children in vehicles equipped with second-generation air bags. Therefore, the AAP continues to strongly recommend that all children younger than 13 years sit in the rear seat. In vehicles with only a single row of seats, such as compact pickup trucks, the frontal air bag can be deactivated, or an on/off switch can be installed, to prevent its deployment in the event of a crash, thus allowing either the installation of a CSS in the front seat or the ability of a child younger than 13 years to ride in the front if necessary.¹⁰⁴

Side air bags were introduced in the mid-1990s as a safety strategy to reduce serious injuries and fatalities occurring in side-impact crashes. Initial crash tests that involved vehicles equipped with so-called torso side air bags in the front seats revealed that the head was still at risk of serious injury in side-impact crashes.^{105,106} To maximize protection of the head for adult front and rear-seat occupants of a variety of statures and seating postures, the roof-rail or head curtain air bag was developed and has become the preferred head-protection system for side-impact crashes. These systems, frequently accompanied by a

separate torso side air bag, provide more extensive coverage of the upper vehicle side interior and often extend the entire length of the vehicle, including the rear rows. Side air bags have become a common safety technology in the vehicle; 79% of model-year 2006 vehicles have some type of side air bag either as standard or optional equipment.¹⁰⁷ The NHTSA recently conducted an analysis of side-impact protection with a focus on side air-bag technology¹⁰⁸ and determined that side air bags resulted in a reduction in struck-side fatality risk of 18% in multivehicle crashes and substantial improvement in a thoracic injury metric, the Thoracic Trauma Index, in laboratory assessments. Benefits were greater for head side air bags than those with torso side air bags alone. However, these analyses were primarily focused on protection of adult drivers and front-seat occupants. Arbogast and Kallan¹⁰⁹ used the Partners for Child Passenger Safety (PCPS) database to estimate the prevalence of side air-bag exposure to children in crashes and to provide estimates of injury risk among those exposed. In the study sample, 2.7% of children in crashes were exposed to a deployed side air bag. More than 75% of these children were seated in the rear seat, and 65% of those exposed were younger than 9 years. Of those exposed, 10.6% sustained an Abbreviated Injury Scale 2 injury to the head or upper extremity, a rate similar to that of children exposed to second-generation frontal air bags. These limited field data on the performance of side air bags with respect to child occupant protection suggest that, although a significant number of children are exposed to side air-bag deployments, there is no evidence that these air bags pose a particular risk of serious or fatal injuries to children.

SPECIAL CONSIDERATIONS

The Safety of Children Left in or Around Vehicles

Children should never be left unattended in or around parked cars. Among the safety risks that have been described, being backed over when the vehicle is set in motion, hyperthermia, and strangulation from entrapment in power windows are among the most serious and preventable injuries. In 2008, Kids and Cars, a safety advocacy group dedicated to the prevention of such injuries, amassed reports of a wide range of safety incidents that involved nearly 1000 children and resulted in more than 200 deaths.¹¹⁰ In response to the Cameron Gulbransen Kids Transportation Safety Act of 2007 (Pub L No. 110-189), the NHTSA created a virtual database called the Not in Traffic Surveillance (NiTS) system to ascertain population-based estimates of the prevalence of noncrash deaths and injuries. NiTS data indicate that approximately 35 to 40 occupants (primarily children) die of hyperthermia and 5 die of power-window strangulation each year, which highlights the importance of never leaving children unsupervised in or around cars.¹¹¹

The Safety of Children in Pickup Trucks

Pickup trucks are popular vehicles in the United States and accounted for approximately 13% of new vehicle sales in 2008.¹¹² Although many have only a single row of seats, extended-cab models have a second row of seats and may be viewed as family vehicles by parents who want to follow safety recommendations that children be placed in the rear seat. Compact extended-cab pickup trucks, which typically have a smaller rear-seat compartment, sometimes with side-facing, fold-down seats, present a particular safety hazard to children. Winston et al¹¹³ found that children in the rear

seat of compact extended-cab pickup trucks were more than 4 times as likely to be injured (adjusted OR: 4.69 [95% CI: 2.44–9.01]) as were rear-row–seated children in other vehicles. A substantial portion of the increased risk was mediated by contact with the vehicle interior during the crash, because the rear-seat compartment in these trucks is typically not as well padded as in other vehicles. It is important to note that full-size extended-cab pickup trucks, which typically have a rear-seat compartment similar in size and configuration to other vehicles, were found to have injury risks similar to those of other passenger vehicles.

Of particular concern regarding the safety of pickup trucks for children is the use of the cargo area of pickup trucks for the transport of children and youth. Because the cargo area is not intended for passenger use, it is neither required nor designed to meet occupant safety standards applicable to passenger locations. The fatality risk to children in the cargo area of pickup trucks has been well described.^{114,115} The most significant hazard of travel in the cargo area of a pickup truck is ejection of a passenger in a crash or noncrash event (eg, sudden stop, turn, swerve, or loss of balance, as well as intentional or unintentional jumps and falls). It is fortunate that the number of children and adolescents younger than 18 years killed as passengers in the cargo area of pickup trucks has declined by more than 50% over the past decade, from more than 40 per year to less than 20 per year more recently.² The most effective prevention strategies for reducing the number of deaths and injuries to children in pickup trucks are the prohibition of travel in the cargo area and age-appropriate restraint use in an appropriate rear-seat location in the cab.

The Safety of Children on Commercial Airlines

Currently, the Federal Aviation Administration (FAA) exempts children younger than 2 years from the requirement that all aircraft passengers occupy a seat with a separate safety belt.¹¹⁶ The FAA and NHTSA agreed on a single government performance standard, FMVSS 213, that would satisfy both aviation and highway safety requirements for child restraint systems.¹¹⁷ The FAA has also approved a harness-type restraint appropriate for children who weigh between 22 and 44 lb. This type of device provides an alternative to using a hard-backed seat and is approved only for use on aircraft. It is not approved for use in motor vehicles.¹¹⁸ Newman et al¹¹⁹ examined the potential impact and costs of a requirement for use of child restraint systems by young children on aircraft. The potential impact of such a regulation requires a number of assumptions, primarily regarding the effectiveness of child restraint systems in survivable aircraft crashes and the proportion of families who would switch from air to ground travel if required to assume the added cost of an additional aircraft seat and the child restraint system for their children younger than 2 years. Using available data on the risk of fatalities from air travel and the survivability of crashes and reasonable assumptions for RRs of death for restrained and unrestrained young children involved in crashes, Newman et al found that the number of deaths that could be prevented in the United States with mandatory child restraint system use in commercial aircraft is small: less than 1 per year. The number of deaths that could be prevented by mandatory child restraint system use is limited, because the number of deaths of unrestrained young children in survivable aircraft crashes is already low. New-

man et al suggested that a policy of requiring child restraint system use for airplane travel is likely to lead to a net increase in deaths caused by increased motor vehicle travel if the proportion of families switching to automobile travel exceeds approximately 5% to 10%. This threshold varied with the estimated number of lives saved by child restraint system use on airplanes, the average length of the added round trips by car, and the risk profile of the drivers but was unlikely to exceed 15%. The National Transportation Safety Board disputed the “diversion” claim made by Newman et al and others and suggested that available data did not indicate that diversion to road travel has previously occurred when circumstances made it likely (eg, immediately after the terrorist attacks on September 11, 2001).¹²⁰

An alternative approach supported by the FAA is to encourage families to inquire about the availability of open seats on less crowded flights so that parents could put their child in a child restraint system in a seat next to them without needing to buy a ticket and without revenue loss to the airline. This approach was also advocated by Bishai¹²¹ in an editorial that accompanied the Newman et al study. If open seats are not available, families would be required to check the CSS as luggage. In 2008, the Department of Federal Affairs surveyed all major US airlines on their baggage policies and learned that with 1 exception, airlines have adopted policies that do not count CSSs toward checked baggage allowances.¹²²

Data fundamental to creating an evidence-based policy, including information on the number of children younger than 2 years of age who currently fly unrestrained, as well as data on the number of children who sustain injuries in turbulence, are not available. Until data systems are created

and used to provide evidence to inform the policy debate and ticket-pricing policies and security screening procedures are enhanced to make it easier for families to follow best-practice recommendations for correct child restraint use during commercial airline travel, and to have their own CSS or booster seat available to them after airline travel, the current situation of allowing young children to travel in a manner inconsistent with best-practice recommendations is likely to continue.

CHILD RESTRAINT LAWS

The first state child occupant restraint law was passed in Tennessee in 1978, primarily attributable to the efforts of pediatrician Robert Sanders. By 1985, all 50 states and the District of Columbia had passed laws requiring child restraints for young children. However, these initial child passenger safety laws were generally inconsistent with best-practice recommendations at the time, which created several gaps in coverage of children and resulted in poor compliance with the provisions of the laws.¹²³ Recognizing the importance of laws in both changing restraint behavior and educating the public about recommended restraint practices, most states have recently enhanced their child occupant restraint laws through the enactment of booster seat use provisions for older children. Current information on all child restraint laws in the United States is updated by the Insurance Institute for Highway Safety and can be found at www.iihs.org/laws/ChildRestraint.aspx. Although the laws aim to ensure the appropriate use of all forms of child restraints (eg, CSSs and belt-positioning booster seats), the revised laws generally became known as “booster seat laws.” Results of subsequent study of the association of a booster seat provision in a state child restraint law with changes in child restraint use in

that state indicated that booster seat provisions that cover children from 4 through 7 years of age increase the use of child restraints by 39% among children in this age range.¹⁶ Children 4 to 5 years of age in states with booster seat laws were 23% more likely to be reported as appropriately restrained than were children in other states, and those 6 to 7 years of age were twice as likely to be reported as appropriately restrained. For 6- to 7-year-olds, the effect was much stronger when the law included children through 7 years of age than when it included only those 4 to 5 years of age.

A focus-group study of violators of California’s child restraint law revealed that multiple complex factors influence consistent use of a CSS.¹²⁴ At the time of the study, the California law required children younger than 4 years and weighing less than 40 lb to be properly secured in a CSS that meets federal standards. Parents who violated the law described a number of factors, including unreliable access to a vehicle, the trip circumstances, parenting style, and child refusal, that affected the use of a CSS at the time of the citation. Among parents who had been ticketed for not restraining their children, participation in a class in which child passenger safety information was provided demonstrated some benefit in their subsequent knowledge of child passenger safety issues, compared with a fine alone.

Seat belt laws have played a critical role in increasing seat belt use by 83% of front-seat occupants by 2008.¹²⁵ However, seat belt use continues to be lower—at 80% in 2008—among drivers and front-seat occupants 16 to 24 years of age. There are 2 different types of enforcement of seat belt laws: primary and secondary enforcement. Primary-enforcement laws allow a ci-

tation to be issued whenever a law enforcement officer observes an unbelted driver or passenger. Secondary enforcement seat belt laws require the officer to stop a violator for another traffic infraction before being able to issue a citation for not using a seat belt. Previous studies have demonstrated that, on average, the effects of primary-enforcement laws are larger and more consistent than secondary-enforcement laws in increasing seat belt use and decreasing injuries among adult drivers and passengers.^{126–129}

Gaps between adult seat belt laws and child restraint laws result in lack of coverage for many older children (5–15 years of age) in all seating positions. For example, in some states, a 15-year-old can ride legally in the back seat without a restraint, because the laws in those states apply only to front-seat occupants. To gain insight on the potential effect of primary-enforcement safety belt laws on older child passengers, Durbin et al¹³⁰ compared reported use of seat belts among 13- to 15-year-old passengers in crashes in states with a primary-enforcement seat belt law versus states with a secondary-enforcement law. Restraint use was 7.2% (95% CI: 4.3%–10.1%) higher among 13- to 15-year-olds in primary-enforcement states versus those in secondary-enforcement states. Restraint use among 13- to 15-year-olds was significantly lower in secondary-enforcement versus primary-enforcement states, particularly when the driver was unrestrained. For 13- to 15-year-olds in a secondary state with an unrestrained driver, 65.8% were unrestrained compared with 22.8% in a primary-enforcement state (adjusted RR: 3.0 [95% CI: 1.5–15.7]). After adjusting for both driver age and restraint use, a 13- to 15-year-old was more than twice as likely to be unrestrained in a secondary-enforcement state com-

pared with a primary-enforcement state (RR: 2.2 [95% CI: 1.4–3.5]). The authors concluded that primary-enforcement laws were associated with higher rates of seat belt use compared with secondary-enforcement laws among children 13 to 15 years of age, a group not generally covered by restraint laws.

RESOURCES FOR PEDIATRICIANS AND FAMILIES

The NHTSA began a standardized child passenger safety training and certification program in 1998. Since then, tens of thousands of people have been certified as child passenger safety technicians.¹³¹ These people participate in community-based child safety seat clinics and are a source of information for families on appropriate use and installation of all types of CSSs and booster seats. Although the algorithm to guide implementation of best-practice recommendations by pediatricians provided in the policy statement is designed to cover the majority of situations that pediatricians will encounter in practice, pediatricians

should consider child passenger safety technicians as sources of information when atypical circumstances may be encountered that are not adequately managed by the algorithm. In most communities, technicians work at formal inspection stations; a list of these stations is available at www.seatcheck.org. If your community does not have an inspection station, you can find a technician in your area via the National Child Passenger Safety Certification Web site (<http://cert.safekids.org>) or the NHTSA child safety seat inspection station locator (www.nhtsa.dot.gov/cps/cpsfitting/index.cfm). Technicians with enhanced training in restraining children with special health needs, as well as those with Spanish-language proficiency, can be identified at these sites. Car seat checkup events are updated at www.safekidsweb.org/events/events.asp. In addition, additional resources for pediatricians and families can be found at www.aap.org and www.healthychildren.org.

LEAD AUTHOR

Dennis R. Durbin, MD, MSCE

COMMITTEE ON INJURY, VIOLENCE, AND POISON PREVENTION, 2008–2010

H. Garry Gardner, MD, Chairperson
 Carl R. Baum, MD
 M. Denise Dowd, MD, MPH
 Dennis R. Durbin, MD, MSCE
 Beth E. Ebel, MD
 Michele Burns Ewald, MD
 Richard Lichenstein, MD
 Mary Ann P. Limbos, MD
 Joseph O'Neil, MD, MPH
 Elizabeth C. Powell, MD
 Kyran P. Quinlan, MD, MPH
 Seth J. Scholer, MD, MPH
 Robert D. Sege, MD, PhD
 Michael S. Turner, MD
 Jeffrey Weiss, MD

CONTRIBUTOR

Stuart Weinberg, MD – *Partnership for Policy Implementation (PPI)*

LIAISONS

Julie Gilchrist, MD – *Centers for Disease Control and Prevention*
 Lynne Janecek Haverkos, MD – *Eunice Kennedy Shriver National Institute of Child Health and Human Development*
 Jonathan D. Midgett, PhD – *Consumer Product Safety Commission*
 Alexander S. Sinclair – *National Highway Traffic Safety Administration*
 Natalie L. Yanchar, MD – *Canadian Paediatric Society*

STAFF

Bonnie Koziol
dshp@aap.org

REFERENCES

- Centers for Disease Control and Prevention. Injury Prevention & Control, Web-Based Injury Statistics Query and Reporting System (WISQARS). Available at: www.cdc.gov/injury/wisqars/index.html. Accessed August 17, 2010
- National Highway Traffic Safety Administration. Fatality Analysis Reporting System encyclopedia. Available at: www.fars.nhtsa.dot.gov. Accessed August 17, 2010
- Pressley JC, Barlow B, Kendig T, Paneth-Pollak R. Twenty-year trends in fatal injuries to very young children: the persistence of racial disparities. *Pediatrics*. 2007;119(4). Available at: www.pediatrics.org/cgi/content/full/119/4/e875
- Garcia AN, Patel KV, Guralnik JM. Seat belt use among American Indians/Alaska Natives and non-Hispanic whites. *Am J Prev Med*. 2007;33(3):200–206
- Daniels F, Moore W, Conti C, et al. The role of the African-American physician in reducing traffic-related injury and death among African Americans: consensus report of the National Medical Association. *J Natl Med Assoc*. 2002;94(2):108–118
- National Highway Traffic Safety Administration. *Seat Belt Use in 2008: Race and Ethnicity Results Among Occupants Traveling With Children*. Washington, DC: National Highway Traffic Safety Administration, National Center for Statistics and Analysis; 2009. DOT HS 811 107: Traffic Safety Facts, Research Note. Available at: www.nrd.nhtsa.dot.gov/Pubs/811107.PDF. Published 2009. Accessed August 17, 2010, 2010
- Falcone RA Jr, Brentley AL, Ricketts CD, Allen SE, Garcia VF. Development, implementation and evaluation of a unique African-American faith-based approach to increase automobile restraint use. *J Natl Med Assoc*. 2006;98(8):1335–1341
- Ebel BE, Koepsell TD, Bennett EE, Rivara FP. Use of child booster seats in motor vehicles following a community campaign: a controlled trial. *JAMA*. 2003;289(7):879–884
- National Highway Traffic Safety Administration. *Traffic Safety Facts 1999: A Compilation of Motor Vehicle Crash Data From the Fatality Analysis Reporting System and the General Estimates System*. Washington, DC: National Highway Traffic Safety Administration; 2000. Available at: www.nhtsa.gov/people/ncsa/809-100.pdf. Accessed August 17, 2010
- Durbin DR, Chen I, Smith R, Elliott MR, Winston FK. Effects of seating position and appropriate restraint use on the risk of injury to children in motor vehicle crashes. *Pediatrics*. 2005;115(3). Available at: www.pediatrics.org/cgi/content/full/115/3/e305
- Braver ER, Ferguson SA, Greene MA, Lund AK. Reductions in deaths in frontal crashes among right front passengers in vehicles equipped with passenger air bags. *JAMA*. 1997;278(17):1437–1439

12. Durbin DR, Elliott MR, Winston FK. Belt-positioning booster seats and reduction in risk of injury among children in vehicle crashes. *JAMA*. 2003;289(21):2835–2840
13. Arbogast KB, Durbin DR, Cornejo RA, Kallan MJ, Winston FK. An evaluation of the effectiveness of forward facing child restraint systems. *Accid Anal Prev*. 2004;36(4):585–589
14. Elliott MR, Kallan MJ, Durbin DR, Winston FK. Effectiveness of child safety seats vs seat belts in reducing risk for death in children in passenger vehicle crashes. *Arch Pediatr Adolesc Med*. 2006;160(6):617–621
15. Nichols JL, Glassbrenner D, Compton RP. The impact of a nationwide effort to reduce airbag-related deaths among children: an examination of fatality trends among younger and older age groups. *J Safety Res*. 2005;36(4):309–320
16. Winston FK, Kallan MJ, Elliott MR, Xie D, Durbin DR. Effect of booster seat laws on appropriate restraint use by children 4 to 7 years old involved in crashes. *Arch Pediatr Adolesc Med*. 2007;161(3):270–275
17. Segui-Gomez M, Wittenberg E, Glass R, Levenson S, Hingson R, Graham JD. Where children sit in cars: the impact of Rhode Island's new legislation. *Am J Public Health*. 2001;91(2):311–313
18. US Department of Transportation, Federal Highway Administration. National Household Travel Survey, 2001. Available at: <http://nhts.ornl.gov>. Accessed August 17, 2010
19. American Academy of Pediatrics, Committee on Injury, Violence, and Poison Prevention. Child passenger safety. *Pediatrics*. 2011;127(4):788–793
20. National Highway Traffic Safety Administration. *Child Restraint Use in 2008: Overall Results*. Washington, DC: National Highway Traffic Safety Administration, National Center for Statistics and Analysis; 2009. DOT HS 811 135: Traffic Safety Facts, Research Note. Available at: www-nrd.nhtsa.dot.gov/Pubs/811135.PDF. Accessed August 17, 2010
21. National Highway Traffic Safety Administration. *Child Restraint Use in 2008: Use of Correct Restraint Types*. Washington, DC: National Highway Traffic Safety Administration, National Center for Statistics and Analysis; 2009. DOT HS 811 132: Traffic Safety Facts, Research Note. Available at: www-nrd.nhtsa.dot.gov/Pubs/811132.PDF. Accessed August 17, 2010
22. National Highway Traffic Safety Administration. *Child Restraint Use in 2008: Demographic Results*. Washington, DC: National Highway Traffic Safety Administration, National Center for Statistics and Analysis; 2009. DOT HS 811 148: Traffic Safety Facts, Research Note. Available at: www-nrd.nhtsa.dot.gov/Pubs/811148.PDF. Accessed August 17, 2010
23. Partners for Child Passenger Safety. *Fact and Trend Report*. Philadelphia, PA: Children's Hospital of Philadelphia; 2008
24. Arbogast KB, Jermakian JS, Kallan MJ, Durbin DR. Effectiveness of belt positioning booster seats: an updated assessment. *Pediatrics*. 2009;124(5):1281–1286
25. Flegal KM. Epidemiologic aspects of overweight and obesity in the United States. *Physiol Behav*. 2005;86(5):599–602
26. Ogden CL, Carroll MD, Curtin LR, McDowell MA, Tabak CJ, Flegal KM. Prevalence of overweight and obesity in the United States, 1999–2004. *JAMA*. 2006;295(13):1549–1555
27. Trifiletti LB, Shields W, Bishai D, McDonald E, Reynaud F, Gielen A. Tipping the scales: obese children and child safety seats. *Pediatrics*. 2006;117(4):1197–1202
28. Pollack KM, Xie D, Arbogast KB, Durbin DR. Body mass index and injury risk among US children 9–15 years old in motor vehicle crashes. *Inj Prev*. 2008;14(6):366–371
29. Haricharan RN, Griffin RL, Barnhart DC, Harmon CM, McGwin G. Injury patterns among obese children involved in motor vehicle collisions. *J Pediatr Surg*. 2009;44(6):1218–1222
30. Zonfrillo MR, Nelson KA, Durbin DR, Kallan MJ. The association of weight percentile and motor vehicle crash injury among 3 to 8 year old children. *Ann Adv Automot Med*. 2010;54:193–199
31. National Highway Traffic Safety Administration. *Seat Belt Use in 2009: Overall Results*. Washington, DC: National Highway Traffic Safety Administration, National Center for Statistics and Analysis; 2009. DOT HS 811 100: Traffic Safety Facts, Research Note. Available at: www-nrd.nhtsa.dot.gov/Pubs/811100.PDF. Accessed August 17, 2010
32. Parikh SN, Wilson L. Hazardous use of car seats outside the car in the United States: 2003–2007. *Pediatrics*. 2010;126(2):352–357
33. Bull MJ, Engle WA; American Academy of Pediatrics, Committee on Injury, Violence, and Poison Prevention and Committee on Fetus and Newborn. Safe transportation of preterm and low birth weight infants at hospital discharge. *Pediatrics*. 2009;123(5):1424–1429
34. Decina LE, Lococo KH. Child restraint system use and misuse in six states. *Accid Anal Prev*. 2005;37(3):583–590
35. Bulger EM, Kaufman R, Mock C. Childhood crash injury patterns associated with restraint misuse: implications for field triage. *Prehosp Disaster Med*. 2008;23(1):9–15
36. Sherwood CP, Ferguson SA, Crandall JR. Factors leading to crash fatalities to children in child restraints. *Annu Proc Assoc Adv Automot Med*. 2003;47:343–359
37. Czernakowski W, Muller M. Misuse mode and effects analysis: an approach to predict and quantify misuse of child restraint systems. *Accid Anal Prev*. 1993;25(3):323–333
38. Willett LD, Leuschen MP, Nelson LS, Nelson RM Jr. Risk of hypoventilation in premature infants in car seats. *J Pediatr*. 1986;109(2):245–248
39. Willett LD, Leuschen MP, Nelson LS, Nelson RM Jr. Ventilatory changes in convalescent infants positioned in car seats. *J Pediatr*. 1989;115(3):451–455
40. Merchant JR, Worwa C, Porter S, Coleman JM, deRegnier RA. Respiratory instability of term and near-term healthy newborn infants in car safety seats. *Pediatrics*. 2001;108(3):647–652
41. Bass JL, Mehta KA, Camara J. Monitoring premature infants in car seats: implementing the American Academy of Pediatrics policy in a community hospital. *Pediatrics*. 1993;91(6):1137–1141
42. Charlton JL, Fildes B, Laemmle R, Smith S, Douglas F. A preliminary evaluation of child restraints and anchorage systems for an Australian car. *Annu Proc Assoc Adv Automot Med*. 2004;48:73–86
43. Sherwood CP, Abdelilah Y, Crandall JR, Stevens SL, Saggese JM, Eichelberger MR. The performance of various rear facing child restraint systems in a frontal crash. *Annu Proc Assoc Adv Automot Med*. 2004;48:303–321
44. Bilston LE, Brown J, Kelly P. Improved protection for children in forward-facing restraints during side impacts. *Traffic Inj Prev*. 2005;6(2):135–146
45. Arbogast KB, Jermakian JS. Field use patterns and performance of child restraints secured by lower anchors and tethers for children (LATCH). *Accid Anal Prev*. 2007;39(3):530–535
46. Decina LE, Lococo KH. Observed LATCH use and misuse characteristics of child restraint systems in seven states. *J Safety Res*. 2007;38(3):273–281
47. American Academy of Pediatrics, Committee on Injury and Poison Prevention. Trans-

- porting children with special health care needs. *Pediatrics*. 1999;104(4 pt 1): 988–992
48. Isaksson-Hellman I, Jakobsson L, Gustafsson C, Norin HA. Trends and effects of child restraint systems based on Volvo's Swedish accident database. In: *Proceedings of Child Occupant Protection 2nd Symposium*. Warrendale, PA: Society of Automotive Engineers Inc; 1997:316
 49. Jakobsson L, Isaksson-Hellman I, Lundell B. Safety for the growing child: experiences from Swedish accident data [Abstr 05-0330]. In: *Proceedings: 19th International Technical Conference on the Enhanced Safety of Vehicles*. Washington, DC: National Highway Traffic Safety Administration; 2005
 50. Henary B, Sherwood CP, Crandall JR, et al. Car safety seats for children: rear facing for best protection. *Inj Prev*. 2007;13(6): 398–402
 51. Kahane CJ. *An Evaluation of Child Passenger Safety: The Effectiveness and Benefits of Safety Seats*. Washington, DC: National Highway Traffic Safety Administration; 1986. DOT HS 806 890
 52. National Highway Traffic Safety Administration. *Revised Estimates of Child Restraint Effectiveness*. Washington, DC: National Highway Traffic Safety Administration; 1996. Available at: www.nhtsa.gov/people/ncsa/pdf/childest.pdf. Accessed August 17, 2010
 53. Zaloshnja E, Miller TR, Hendrie D. Effectiveness of child safety seats vs safety belts for children aged 2 to 3 years. *Arch Pediatr Adolesc Med*. 2007;161(1):65–68
 54. Levitt SD. Evidence that seat belts are as effective as child safety seats in preventing death for children aged two and up. *Rev Econ Stat*. 2008;90(1):158–163
 55. Elliott MR, Durbin DR, Winston FK. A propensity score approach to estimating child restraint effectiveness in preventing mortality. *Stat Interface*. 2009;2(4):12
 56. Klinich KD, Pritz HB, Beebe MS, Welty K, Burton RW. *Study of Older Child Restraint/Booster Seat Fit and NASS Injury Analysis*. Washington, DC: National Highway Traffic Safety Administration; 1994. DOT HS 808 248
 57. Durbin DR, Arbogast KB, Moll EK. Seat belt syndrome in children: a case report and review of the literature. *Pediatr Emerg Care*. 2001;17(6):474–477
 58. Kulowski J, Rost WB. Intra-abdominal injury from safety belt in auto accident: report of a case. *AMA Arch Surg*. 1956;73(6): 970–971
 59. Garrett JW, Braunstein PW. The seat belt syndrome. *J Trauma*. 1962;2:220–238
 60. Corden TE. Analysis of booster seat and seat belt use: how many Wisconsin childhood deaths and hospitalizations could have been prevented in 1998–2002? *WMMJ*. 2005;104(1):42–45
 61. Rice TM, Anderson CL, Lee AS. The association between booster seat use and risk of death among motor vehicle occupants aged 4–8: a matched cohort study. *Inj Prev*. 2009;15(6):379–383
 62. Weber K, Melvin JW. Injury potential with misused child restraining systems. In: *Proceedings of the 27th Stapp Car Crash Conference*. Warrendale, PA: Society of Automotive Engineers; 1983:53–59
 63. Henderson M, Brown J, Paine M. Injuries to restrained children. *Annu Proc Assoc Adv Automot Med*. 1994;38:75–87
 64. Sherwood CP, Abdelilah Y, Crandall JR. Quantifying the relationship between vehicle interior geometry and child restraint systems. *Annu Proc Assoc Adv Automot Med*. 2006;50:381–396
 65. Sherwood CP, Crandall JR, Stevens SL, Saggese JM, Eichelberger MR. Sled tests and CIREN data illustrating the benefits of booster seats. *Int J Crashworthiness*. 2005;10(4):8
 66. Kirley BB, Teoh ER, Lund AK, Arbogast KB, Kallan MJ, Durbin DR. Making the most of the worst-case scenario: should belt-positioning booster seats be used in lap-belt-only seating positions? *Traffic Inj Prev*. 2009;10(6):580–583
 67. Kahane CJ. *Lives Saved by the Federal Motor Vehicle Safety Standards and Other Vehicle Safety Technologies, 1960–2002*. Washington, DC: National Highway Traffic Safety Administration, National Center for Statistics and Analysis, Evaluation Division; 2004. DOT HS 809 833. Available at: www-nrd.nhtsa.dot.gov/Pubs/809833.PDF. Accessed August 17, 2010
 68. Arbogast KB, Durbin DR, Kallan MJ, Winston FK. Evaluation of pediatric use patterns and performance of lap shoulder belt systems in the center rear. *Annu Proc Assoc Adv Automot Med*. 2004;48:57–72
 69. Parenteau CS, Viano DC, Shah M, et al. Field relevance of a suite of rollover tests to real-world crashes and injuries. *Accid Anal Prev*. 2003;35(1):103–110
 70. Morgan C. *Effectiveness of Lap/Shoulder Belts in the Back Outboard Seating Positions*. Washington, DC: National Highway Traffic Safety Administration, Evaluation Division, Plans and Policy; 1999. DOT HS 808 945. Available at: www-nrd.nhtsa.dot.gov/Pubs/808945.PDF. Accessed August 17, 2010
 71. Chipman ML. Risk factors for injury: similarities and differences for traffic crashes and other causes. *Accid Anal Prev*. 1995; 27(5):699–706
 72. Kindelberger J, Starnes M. *Moving Children From the Front Seat to the Back Seat: The Influence of Child Safety Campaigns*. Washington, DC: National Highway Traffic Safety Administration, National Center for Statistics and Analysis; 2002. DOT HS 809 698: Traffic Safety Facts, Research Note. Available at: www-nrd.nhtsa.dot.gov/Pubs/809-698.PDF. Accessed August 17, 2010
 73. Durbin DR, Chen I, Elliott M, Winston FK. Factors associated with front row seating of children in motor vehicle crashes. *Epidemiology*. 2004;15(3):345–349
 74. Kallan MJ, Durbin DR, Arbogast KB. Seating patterns and corresponding risk of injury among 0- to 3-year-old children in child safety seats. *Pediatrics*. 2008;121(5). Available at: www.pediatrics.org/cgi/content/full/121/5/e1342
 75. Berg MD, Cook L, Corneli HM, Vernon DD, Dean JM. Effect of seating position and restraint use on injuries to children in motor vehicle crashes. *Pediatrics*. 2000;105(4 pt 1):831–835
 76. Lennon A, Siskind V, Haworth N. Rear seat safer: seating position, restraint use and injuries in children in traffic crashes in Victoria, Australia. *Accid Anal Prev*. 2008; 40(2):829–834
 77. Durbin DR, Elliott M, Arbogast KB, Anderko RL, Winston FK. The effect of seating position on risk of injury for children in side impact collisions. *Annu Proc Assoc Adv Automot Med*. 2001;45:61–72
 78. Ehrlich PF, Brown JK, Sochor MR, Wang SC, Eichelberger ME. Factors influencing pediatric injury severity score and Glasgow coma scale in pediatric automobile crashes: results from the Crash Injury Research Engineering Network. *J Pediatr Surg*. 2006;41(11):1854–1858
 79. Lund UJ. The effect of seating location on the injury of properly restrained children in child safety seats. *Accid Anal Prev*. 2005; 37(3):435–439
 80. Centers for Disease Control and Prevention. Air-bag-associated fatal injuries to infants and children riding in front passenger seats: United States. *MMWR Morb Mortal Wkly Rep*. 1995;44(45):845–847
 81. Huff GF, Bagwell SP, Bachman D. Airbag injuries in infants and children: a case report and review of the literature. *Pediat-*

- rics. 1998;102(1). Available at: www.pediatrics.org/cgi/content/full/102/1/e2
82. Willis BK, Smith JL, Falkner LD, Vernon DD, Walker ML. Fatal air bag mediated cranio-cervical trauma in a child. *Pediatr Neurosurg*. 1996;24(6):323–327
 83. Hollands CM, Winston FK, Stafford PW, Shochat SJ. Severe head injury caused by air-bag deployment. *J Trauma*. 1996;41(5):920–922
 84. Centers for Disease Control and Prevention. Update: fatal air bag-related injuries to children—United States, 1993–1996 [published correction appears in *MMWR Morb Mortal Wkly Rep*. 1997;46(2):40]. *MMWR Morb Mortal Wkly Rep*. 1996;45(49):1073–1076
 85. Marshall KW, Koch BL, Egelhoff JC. Air bag-related deaths and serious injuries in children: injury patterns and imaging findings. *AJNR Am J Neuroradiol*. 1998;19(9):1599–1607
 86. Winston FK, Reed R. Airbags and children: results of a National Highway Traffic Administration special investigation into actual crashes. In: *40th Stapp Car Crash Conference: Albuquerque, NM*. Ann Arbor, MI: Stapp Car Crash Conference; 1996
 87. Mikhail JN, Huelke DF. Air bags: an update. *J Emerg Nurs*. 1997;23(5):439–445
 88. Augenstein JS, Digges KH, Lombardo LV, et al. Occult abdominal injuries to airbag-protected crash victims: a challenge to trauma systems. *J Trauma*. 1995;38(4):502–508
 89. McKay MP, Jolly BT. A retrospective review of air bag deaths. *Acad Emerg Med*. 1999;6(7):708–714
 90. Shkrum MJ, McClafferty KJ, Nowak ES, German A. Driver and front seat passenger fatalities associated with air bag deployment. Part 2: a review of injury patterns and investigative issues. *J Forensic Sci*. 2002;47(5):1035–1040
 91. Ball DC, Bouchard GS. Ocular morbidity associated with airbag deployment: a report of seven cases and a review of the literature. *Cornea*. 2001;20(2):159–163
 92. Arbogast KB, DeNardo MB, Xavier AM, Kallan MJ, Durbin DR, Winston FK. Upper extremity fractures in restrained children exposed to passenger airbags. In: *SAE World Congress & Exhibition: Detroit, MI*. Warrendale, PA: SAE International; 2003
 93. Mittal MK, Kallan MJ, Durbin DR. Breathing difficulty and tinnitus among children exposed to airbag deployment. *Accid Anal Prev*. 2007;39(3):624–628
 94. Kahane CJ. *Fatality Reduction by Air Bags: Analysis of Accident Data Through Early 1996*. Washington, DC: National Highway Traffic Safety Administration, Evaluation Division, Plans and Policy; 1996
 95. Braver ER, Whitfield R, Ferguson SA. Seating positions and children's risk of dying in motor vehicle crashes. *Inj Prev*. 1998;4(3):181–187
 96. Cummings P, Koepsell TD, Rivara FP, McKnight B, Mack C. Air bags and passenger fatality according to passenger age and restraint use. *Epidemiology*. 2002;13(5):525–532
 97. Newgard CD, Lewis RJ. Effects of child age and body size on serious injury from passenger air-bag presence in motor vehicle crashes. *Pediatrics*. 2005;115(6):1579–1585
 98. Smith KM, Cummings P. Passenger seating position and the risk of passenger death in traffic crashes: a matched cohort study. *Inj Prev*. 2006;12(2):83–86
 99. Federal Motor Vehicle Safety Standard and Regulation. In: *Part 571, Federal Motor Vehicle Safety Standards: Crashworthiness, No. 208*. Washington, DC: Department of Transportation; 1998
 100. Olson CM, Cummings P, Rivara FP. Association of first- and second-generation air bags with front occupant death in car crashes: a matched cohort study. *Am J Epidemiol*. 2006;164(2):161–169
 101. Arbogast KB, Durbin DR, Kallan MJ, Winston FK. Effect of vehicle type on the performance of second generation air bags for child occupants. *Annu Proc Assoc Adv Automot Med*. 2003;47:85–99
 102. Braver ER, Scerbo M, Kufera JA, Alexander MT, Volpini K, Lloyd JP. Deaths among drivers and right-front passengers in frontal collisions: redesigned air bags relative to first-generation air bags. *Traffic Inj Prev*. 2008;9(1):48–58
 103. Kuppa S, Saunders J, Fessahaie O. *Rear Seat Occupant Protection in Frontal Crashes*. Washington, DC: National Highway Traffic Safety Administration; 2005. Available at: www-nrd.nhtsa.dot.gov/pdf/esv/esv19/05-0212-0.pdf. Accessed August 17, 2010
 104. Department of Transportation, National Highway Traffic Safety Administration. Air bag deactivation. Available at: www.nhtsa.gov/cars/rules/rulings/deactnpr.n21.html. Accessed August 17, 2010
 105. Dalmotas D, German A, Tylko S. The crash and field performance of side-mounted airbag systems. Presented at: 17th Enhanced Safety of Vehicles Conference; June 4–7, 2001; Amsterdam, Netherlands
 106. Prasad A, Samaha R, Loudon A. Evaluation of injury risk from side impact air bags. Presented at: 17th Enhanced Safety of Vehicles Conference; June 4–7, 2001; Amsterdam, Netherlands
 107. McCartt A, Kyrchenko S. Efficacy of side air bags in reducing driver deaths in driver-side car and SUV collisions. *Traffic Inj Prev*. 2007;8(2):162–170
 108. Kahane CJ. *An Evaluation of Side Impact Protection*. Washington, DC: National Highway Traffic Safety Administration, Evaluation Division; 2007. Available at: www-nrd.nhtsa.dot.gov/Pubs/810748.PDF. Accessed August 17, 2010
 109. Arbogast KB, Kallan MJ. The exposure of children to deploying side air bags: an initial field assessment. *Annu Proc Assoc Adv Automot Med*. 2007;51:245–259
 110. Kids and Cars. Home page. Available at: www.kidsandcars.org. Accessed August 17, 2010
 111. National Highway Traffic Safety Administration. *Not-in-Traffic Surveillance 2007: Highlights*. National Highway Traffic Safety Administration, National Center for Statistics and Analysis; 2009. DOT HS 811 085: Traffic Safety Facts, Crash Stats. Available at: www-nrd.nhtsa.dot.gov/Pubs/811085.PDF. Accessed August 17, 2010
 112. US Environmental Protection Agency. Light-Duty Automotive Technology, Carbon Dioxide Emissions, and Fuel Economy Trends: 1975 Through 2009. EPA420-R-09-014. Washington, DC: US Environmental Protection Agency; November 2009. Available at: <http://www.epa.gov/otaq/cert/mpg/fetrends/420r09014.pdf>. Accessed February 23, 2011
 113. Winston FK, Durbin DR, Kallan MJ, Elliott MR. Rear seating and risk of injury to child occupants by vehicle type. *Annu Proc Assoc Adv Automot Med*. 2001;45:51–60
 114. Agran PF, Winn DG, Castillo DN. Pediatric injuries in the back of pickup trucks. *JAMA*. 1990;264(6):712–716
 115. Anderson CL, Agran PF, Winn DG, Greenland S. Fatalities to occupants of cargo areas of pickup trucks. *Accid Anal Prev*. 2000;32(4):533–540
 116. Federal Aviation Administration. 14 CFR 135.128. Available at: www.carseat.org/Legal/FAA14cfr135.128.pdf. Accessed August 17, 2010
 117. Federal Motor Vehicle Safety Standard No. 213. 49 CFR 571.213. Available at: http://edocket.access.gpo.gov/cfr_2004/octqtr/49cfr571.213.htm. Accessed August 17, 2010
 118. Federal Aviation Authority. Child safety on airplanes. Available at: www.faa.gov/

- passengers/fly_children/crs. Accessed August 17, 2010
119. Newman TB, Johnston BD, Grossman DC. Effects and costs of requiring child-restraint systems for young children traveling on commercial airplanes. *Arch Pediatr Adolesc Med.* 2003;157(10):969–974
 120. National Transportation Safety Board. Analysis of Diversion to Automobile in Regard to the Disposition of Safety Recommendation A-95-51, Disposition of Safety Recommendation NTSB/SR-A-95-51. Washington, DC: Washington, DC: National Transportation Safety Board; 2004. Available at: http://www.nts.gov/aviation/sr_a-95-51_diversion_analysis.pdf. Accessed February 23, 2011
 121. Bishai D. Hearts and minds and child restraints in airplanes. *Arch Pediatr Adolesc Med.* 2003;157(10):953–954
 122. Expedia. Airline fee chart. Available at: www.expedia.com/daily/flights/airline-fees.asp. Accessed August 17, 2010
 123. Staunton C, Davidson S, Kegler S, Dawson L, Powell K, Dellinger A. Critical gaps in child passenger safety practices, surveillance, and legislation: Georgia, 2001. *Pediatrics.* 2005;115(2):372–379
 124. Agran PF, Anderson CL, Winn DG. Violators of a child passenger safety law. *Pediatrics.* 2004;114(1):109–115
 125. National Highway Traffic Safety Administration. *Seat Belt Use in 2008: Demographic Results*. Washington, DC: National Highway Traffic Safety Administration; National Center for Statistics and Analysis; 2009. DOT HS 811 183: Traffic Safety Facts, Research Note. Available at: www.nrd.nhtsa.dot.gov/Pubs/811183.PDF. Accessed August 17, 2010
 126. Rivara FP, Thompson DC, Cummings P. Effectiveness of primary and secondary enforced seat belt laws. *Am J Prev Med.* 1999; 16(1 suppl):30–39
 127. Eby DW, Fordyce TA, Vivoda JM. A comparison of safety belt use between commercial and noncommercial light-vehicle occupants. *Accid Anal Prev.* 2002; 34(3):285–291
 128. Houston DJ, Richardson LE, Jr Traffic safety and the switch to a primary seat belt law: the California experience. *Accid Anal Prev.* 2002;34(6):743–751
 129. Centers for Disease Control and Prevention. Impact of primary laws on adult use of safety belts: United States, 2002. *MMWR Morb Mortal Wkly Rep.* 2004;53(12):257–260
 130. Durbin DR, Smith R, Kallan MJ, Elliott MR, Winston FK. Seat belt use among 13–15 year olds in primary and secondary enforcement law states. *Accid Anal Prev.* 2007;39(3):524–529
 131. National CPS Certification. Home page. Available at: www.safekids.org/certification. Accessed August 17, 2010



**National Association
of State Directors
of Pupil Transportation Services**

Information Report

Sharing Student Health and Medical Information with School Transporters Revised, October 2014

by Peggy A. Burns, Esq.

Background

This Information Report is not intended to be an exhaustive discussion of student records disclosure and confidentiality provisions, since there are multiple situations in which school transporters require student information in order to safely and efficiently carry out their responsibilities. Rather, it focuses on communicating to school transporters and special education directors the necessity -- and legitimacy -- of disclosure of student health and medical information. Included in the category of “school transporters” are transportation administrators, drivers, and other appropriate school transportation staff members, as well as bus contractors hired by school districts and educational units to transport students to and from school and school activities. School transporters and special education directors are urged to seek legal advice regarding specific applications of this information.

It is critical that school transporters have relevant health and medical information about the students who ride their buses, and in some cases it is legally mandated. Even where there is not a statutory or regulatory mandate to provide this information to school transporters, any reasonable risk management analysis readily leads to the conclusion that the potential harm from failure to share this information far outweighs any risk that a school district or contractor could incur as a result of transporters having this information.

It has long been true that, with parental permission, school administrators can share student information – including health and medical information – with school bus personnel. But obtaining prior permission from parents can be difficult and time-consuming, and laws and regulations recognize that educators and service providers may sometimes need to have access to student information without parental permission.

Despite these facts, however, special education administrators and other school personnel are often reluctant to share student health and medical information with school transporters. Many are adamant about their “inability” to provide information about students’ conditions and needs which may impact travel on the school bus. The reason: misinformation about and/or misunderstanding of the law’s confidentiality requirements.

Questions.

- Can school transporters legally receive health and medical information about students who ride their buses?
- What factors should be considered in determining whether transportation personnel, special education personnel, medical personnel and parents should collaborate to accomplish this sharing of information?
- What are the prerequisites to the sharing of student health information with school transporters?
- How can compliance with these prerequisites be achieved

Discussion

Application of relevant statutory and regulatory information.

Several clear guiding principles emerge from an understanding of applicable law, especially the Regulations implementing Part B of the Individuals with Disabilities Education Act (hereafter, "IDEA"), and the Family Educational Rights and Privacy Act of 1974 (hereafter, "FERPA.")

Principle 1 -- Rationale for Disclosure

School transportation professionals need operational information about the way in which a student's special needs impact the ride, and necessary accommodations and modifications that the transportation department must implement. Knowing a child's diagnosis or "label" isn't enough and, in fact, is of limited actual value. Instead, school transportation professionals need to know "the what" and "the how" of *this* child's disability-related transportation needs, 34 CFR 300.323(d).

Federal agencies have begun to recognize the strong rationale for disclosure of student information to pupil transportation professionals. In a document setting forth "Questions and Answers on Serving Children with Disabilities Eligible for Transportation" released on November 9, 2009, the Office of Special Education and Rehabilitative Services (OSERS) reiterated a statement by the Office of Special Education Programs (OSEP) in its August 22, 2003 *Memorandum to State Directors of Special Education* (<https://www2.ed.gov/policy/speced/guid/idea/letters/2003-3/leeds082203relsvcs3q2003.pdf>) recognizing that, "Transportation providers play an integral role in the school lives of many children, including children with disabilities." OSERS marked the "essential" need for "effective communication between school and transportation providers."

When transportation is provided as a related service to a special education student -- that is, because transportation is necessary for the child to access Individualized Education Program (IEP) services -- then transporters are related service providers. [See IDEA Regulations (hereafter "Regs"), Section 300.24.] Under such circumstances, the school district *must* provide necessary information to school transporters. That information includes setting forth the role of transportation personnel in meeting the unique needs of the child as identified in his/her IEP, and those "accommodations, modifications, and supports" identified in the child's IEP which relate in any way to the transportation environment. [See Regs., Section 300.342(b) (2) and (3).]

Furthermore, related services providers must receive information about relevant IEP changes when the changes are made without the direct involvement of those providers. Specifically, when an IEP has been revised – and there are times this can occur without an IEP meeting – the Analysis states that “it is important that the personnel responsible for implementing the revised IEP be notified and informed of the changes with respect to their particular responsibilities.” That means, for example, that if a behavior intervention plan is added to an IEP in response to behavior which a student displays both in the classroom and on the school bus, the child’s driver and attendant should be notified of any responsibilities under the plan.

While the IDEA Regulations impose a mandatory duty on school districts when transportation is a related service, FERPA gives broader permission to disclose information about a child under two situations:

- (1) when a parent consents to the disclosure; or
- (2) to “school officials” with a “legitimate educational interest” even when the district has not obtained such prior consent.

Who is a school official with a legitimate educational interest?

When FERPA was modified in 1996, a “Model Notification of Rights Under FERPA for Elementary and Secondary Institutions” was included in Appendix B. That Model Notification clearly demonstrates Congressional intent as to who might reasonably be entitled to receive student information:

“A school official is a person employed by the District as an administrator, supervisor, instructor or support staff member. . .; a person serving on the School Board; a person or company with whom the District has contracted to perform a special task. . .”

And, a school official has “a **legitimate educational interest** if the official needs to review an education record in order to fulfill his or her professional responsibility.”

It is clear that school transporters meet this standard when having and understanding student health and medical information is necessary to enable the safe and efficient transport of a student.

Principle 2 -- Publication of Criteria for Disclosure.

Under FERPA, school districts and contractors must annually publish a notification to parents that includes the district’s criteria for disclosing student information to school officials without parental permission, 34 CFR 99.7. The Official Commentary to the FERPA regulations states, “At the discretion of a school [district], school officials may include school transportation officials (including bus drivers. . .” among those entitled to have information necessary to enable them to do their jobs, and, therefore, privy to student information without parental permission.

The 2006 Amendments to the IDEA regulations underscore the need for service providers who work directly with students with disabilities to have access to necessary information. Each related service provider must have access to the child’s IEP and be informed of his or her specific responsibilities related to implementing the IEP, and of the “specific accommodations, modifications, and supports that must be provided to the child in accordance with the IEP, 34 CFR 300.323(d). How this information is conveyed is left up to individual school districts.

These combined requirements are easily met by including in student/parent handbooks a statement like the

following suggested in Appendix B to FERPA:

“Federal law permits the school district to disclose personally identifiable information in the student’s education records to ‘school officials with legitimate educational interests.’ School officials include persons employed by the district as an administrator, supervisor, teacher, or support staff member (including but not limited to, . . . transportation personnel. . .); . . . a person, agency, or company with whom the District has contracted, or otherwise arranged to perform a special task or service. . . Such individuals have a legitimate educational interest if s/he needs to review an education record in order to fulfill his or her professional and/or official responsibility. A legitimate educational interest also exists where the staff member or other individual works directly with students and needs to review education records to increase his/her awareness of steps necessary for the safety and welfare of students and staff members.”

Principle 3 – Confidentiality.

The IDEA Regulations recognize that confidentiality requirements apply to the provision of necessary student information to school district employees and school transportation contractors. These requirements do not prohibit disclosure, but merely impose on “agency or institution that collects, maintains or uses personally identifiable information, or from which information is obtained” the duty to protect the confidentiality of such information “at collection, storage, disclosure and destruction stages.” [See Regs., Sec. 300.572 (a).] This duty is further defined by the FERPA requirement that a school district share personally identifiable information from an education record only on the condition that the recipient of the information will not disclose the information to any other party without the prior consent of the parent or eligible student.

School bus companies must be under the “direct control” of the district regarding the use and maintenance of education records. This requirement may be fulfilled by including allocation of responsibilities and mutual understandings in the contract between the parties.

In addition, transportation departments and school bus companies must make reasonable efforts to protect the student information they receive, whether they use physical means, like keeping the information under lock; or administrative means, through the use of training and policies prohibiting all disclosure other than sharing with another school official who has a legitimate educational interest; or key technological means like providing it on computers only when password-protected. Protocols concerning student information security should be codified in a policy that is widely distributed, implemented, and monitored. The federal Privacy Technical Assistance Center (PTAC) has developed a body of best practice resources to help education stakeholders in this sometimes complicated arena. The PTAC “toolkit” includes case studies, webinars, checklists and other information related to (1) data sharing, (2) disclosure avoidance, (3) security best practices, (4) data governance, and (5) legal references. Please see: <http://ptac.ed.gov/toolkit>.

Since student information is, increasingly, stored electronically on in-house or cloud-based servers, more needs to be said about this evolving area of information maintenance. Consider requiring those who claim a need to access student information via technology to fill out a specific request form, indicating, among other details, the specific business reason for the need, and a statement as to why the information is not available in another way. When student information is stored or communicated electronically, current best practices and applicable policies for electronic information security should be followed. It is wise to employ or contract for the services of professionals with expertise in this area who can serve as resources and provide guidance or training to prevent and, if necessary, address, a security breach.

For additional information on keeping student information secure, see the PTAC website, <http://ptac.ed.gov/>.

Principle 4 – Training.

In order to receive student information which is otherwise confidential, school transporters must receive training -- like all other personnel who receive this information in the course of their job duties.

All related services personnel must be “trained,” and the Official Commentary to Section 300.24 of the Regs specifically includes “bus drivers” among such personnel. The Regs further state that “all persons collecting or using personally identifiable information must receive training or instruction regarding” limitations imposed by IDEA and FERPA and state policies and procedures which implement the disclosure and confidentiality provisions of these federal laws. [See Regs., Section 300. 572 (c).]

The Bottom Line: Why Should School Districts Ensure That Pupil Transportation Officials Have Access to Student Information?

Participation in IEP Meetings.

As indicated above, the duty to inform is mandatory under IDEA Regulations when school transportation is provided as a related service. School transporters are essential participants in the decision which must be made as to whether transportation is a related service for a particular child. Section 300.344 of the Regs provides that a local education agency may include related services personnel as appropriate at the IEP meeting. Appendix A of the IDEA Regulations include many useful questions and answers.

- The answer to Question 30 states: “. . . [I]t is appropriate for [related services personnel] to be included if a particular related service is to be discussed as part of the IEP meeting.”
- The answer to Question 33 states: “In determining whether to include transportation in a child’s IEP and whether the child needs to receive transportation as a related service, it would be appropriate to have at the IEP meeting a person with expertise in that area.” That expertise will be most evident -- and most valuable -- when members of the IEP team have necessary information about the needs of the student.

In its *Letter to Smith* (July 12, 1995), and in a number of letters and opinions since then, the Office of Special Education Programs (OSEP) of the U.S. Department of Education stated that the IEP must include more than a “yes” or “no” to the question “Is transportation a related service?” Rather, it must include accommodation, modifications, and supports which must be provided for the child in accordance with his/her unique needs. Transporters are likely to be more aware of the availability of assistive technology devices applicable to transportation than anyone else on the IEP team, and certainly will have the responsibility to properly use such devices in response to the child’s needs. Health and medical information is essential to this end. OSEP has specifically noted in *Letter to Smith*: “In all instances, each student’s need for transportation as a related service and the type of transportation to be provided are issues to be discussed and decided during the evaluation process and individualized education program (IEP) meeting, and the transportation arrangements agreed upon should be included in the disabled student’s IEP.”

“Transportation arrangements” are obvious components of the information transporters must receive. But remember, Section 300.342(b)(3) of the Regulations implementing Part B of the IDEA mandates that each related service provider know what s/he must do specifically to implement the IDEA. Consequently, other information such as behavior intervention plans or assistive technology details must be shared with transporters to comply with this provision.

Finally, in order to determine necessary components of training for transporters, it is critical to share student health and medical information with driver trainers, and the occupational therapists, physical therapists, nurses and others who will work with them. How else can drivers and bus attendants be aware of proper responses to the unique medical needs of students?

Are There Risks to School Districts if Information is shared with Transporters?

Generally, a single mistake by a school district or contractor will not amount to a violation of FERPA. However, the Family Compliance Office of the U.S. Department of Education, which investigates, processes and reviews complaints and violations under FERPA, may take steps regarding individuals who improperly disclose information from education records. Section 99.33 of the Regulations implementing FERPA provides:

“If this Office determines that a third party improperly re-discloses personally identifiable information from education records in violation of [FERPA], the educational agency or institution may not allow that third party access to personally identifiable information from education records for at least five years.”

The implications of this section are significant. Since a school district makes a commitment when sharing information with a bus driver that the driver will not inappropriately “re-disclose” the information to a third party, there can be strong sanctions if that condition is not met. Since a driver needs certain information in order to do his/her job, a restriction which prevents access to necessary information for at least five years means that the driver cannot do his or her job. That situation would most likely result in termination. Even absent federal agency determination of a breach of confidentiality, or a privately brought action based on invasion of privacy or inaccuracy of the information, a school district might well consider this a sufficiently serious rule violation to impose consequences up to and including termination.

A school district violates FERPA if it has a policy of denying access to records to parents, or it has a policy of wrongly disclosing information to third parties. A parent or student over the age of 18 may file a complaint giving specifics about why that person thinks a school district has violated FERPA. The complaint must be submitted within 180 days of the alleged violation or of the date that the complainant knew of or reasonably should have known of the alleged violation. Following an agency investigation in which it is determined that a violation has occurred; the Family Compliance Office may take a number of steps:

- It will give the school district a reasonable period of time to comply with specific steps set out by the Office; and
- If the school district does not comply within that period, the Office may withhold federal monies, and/or issue an order to compel compliance.

Before the extreme sanction of loss of eligibility for federal funds is applied, a school district must not only have a policy of violation, but also refuse to take steps to comply with FERPA within a reasonable period of

time. Therefore, the school district which shares necessary information with drivers risks little. That is especially true in comparison with the potential risks to the safety and welfare of the student if important information is not shared. On the other hand, the driver who does not take that responsibility seriously risks losing his or her job.

What about the Health Insurance Portability and Accountability Act of 1996 (HIPAA; final Privacy Rule at 45 CFR 160 and 164)

The relationship between HIPAA and FERPA has, apparently, been a source of confusion that has led well-meaning school administrators to refuse to share student medical and health information with school transportation professionals on grounds that such sharing would constitute a violation of HIPAA. But see the joint guidance document from the Department of Education and the Department of Health and Human Services (<http://www2.ed.gov/policy/gen/guid/fpco/doc/ferpa-hipaa-guidance.pdf>) first published in 2008, that helps to sort out the relationship between FERPA and HIPAA. An invaluable resource for educators and school transportation professionals, it includes an overview of FERPA, an overview of HIPAA, a discussion of places the two laws may intersect, and FAQ's. In general, the HIPAA Privacy Rule does not apply to an elementary or secondary school: they are typically not HIPAA covered entities. Rather, student health and medical records held by schools are subject to FERPA, as described above, and HIPAA in no way prevents disclosure of necessary information to school transporters.

Conclusion

School transporters can legally receive information about students' health and medical conditions when these conditions may impact transportation planning and implementation. Factors to be considered in setting conditions for such disclosure include: the determination of legitimate educational interest; compliance with FERPA requirements of notice; requiring confidentiality of the transporters to whom the information is disclosed, and, training. It is clear that once transporters are trained regarding the requirement of confidentiality, school district and medical personnel are well-advised to share this information.

© National Association of State Directors of Pupil Transportation Services. All rights reserved.
October 2014

BIOGRAPHICAL INFORMATION: PEGGY A. BURNS, ESQ.

Peggy Burns served as in-house legal counsel for a large suburban school district in Colorado for twenty years. She now consults full-time as the founder and president of Education Compliance Group, an organization committed to addressing compliance issues in education. A former high school English and forensics teacher, and licensed attorney for more than thirty years, Peggy has devoted the past twenty-seven years specifically to legal issues affecting public education.

Peggy is sought after as a presenter at state, regional, and national conferences, focusing most often on legal issues related to school transportation and special education. She works with school districts and

bus companies to avoid risk, solve problems, and enhance policy and training. Peggy serves as a Tenured Faculty Member for the National Board of Advisors of the National Conference and Exhibition on Transporting Students with Disabilities. She is editor of **Legal Routes**, and a frequent contributor to other industry publications. She demonstrates her commitment to the pupil transportation industry with her accessibility and willingness to support school transportation professionals everywhere.

Peggy is the author, with Lisa J. Hudson, of the book **Defensible Decisions about Transporting Students with Special Needs: Lessons Learned from Legal Disputes**. She is also the author of four training video programs for school bus drivers. Peggy is also the co-author of a Risk Management Manual for Utica National Insurance Company.

AMERICAN ACADEMY OF PEDIATRICS

Committee on Injury and Poison Prevention

School Bus Transportation of Children With Special Health Care Needs

ABSTRACT. School systems are responsible for ensuring that children with special needs are safely transported on all forms of federally approved transportation provided by the school system, and a plan should be developed to provide the most current and proper support to children with special transportation requirements. This statement provides current guidelines for the protection of child passengers with specific health care needs, including those with a tracheostomy, those requiring use of car seats, or those transported in wheelchairs. Guidelines that apply to general school transportation should be followed, including the training of staff, provision of nurses or aides if needed, establishment of a written emergency evacuation plan, and a comprehensive infection control program.

Research provides the basis for recommendations concerning occupant securement for children in wheelchairs and children with other special needs who are transported on a school bus. Pediatricians can help their patients by being aware of guidelines for restraint systems for children with special needs and by remaining informed of new resources. Pediatricians can also play an important role at the state and local level in the development of school bus specifications.

ABBREVIATIONS. FMVSS, Federal Motor Vehicle Safety Standards; IEP, Individual Education Plan; IFSP, Individual Family Service Plan; OSHA, Occupational Safety and Health Administration.

INTRODUCTION

Many preschool-aged and school-aged children with special needs are transported in school buses. The Individuals With Disabilities Education Act 1997 (Public Law 105-17) has established requirements for preschool children ages 3 to 5 to have access to related services (ie, audiology and occupational therapy). It also requires that infants and toddlers (birth to 3 years of age) have access to these same services; however, it does not specify how these children are to be transported to these services if they are to be conducted outside of the child's natural home or school environment. Although the provider could vary from state to state, it is often the responsibility of the school systems to provide these related services to infants and toddlers.

The Federal Motor Vehicle Safety Standards and Regulations (FMVSS) 222 (School Bus Passenger Seating and Crash Protection) established safety re-

quirements for school bus interiors, but it applied only to able-bodied children. However, a 1994 amendment to FMVSS 222 applied to the securement of wheelchairs and their occupants in school buses.¹ National recommended standards for special education school buses were revised in May 1995 by the Twelfth National Standards Conference on School Transportation.²

Wheelchairs are the primary mode of transport on the school bus for many children with special needs. Most wheelchairs have not been developed as certified transit devices and are not currently subjected to any crash-testing requirements. A certified transit wheelchair is one that meets voluntary design and performance requirements for use as a seat by their occupant when traveling in a motor vehicle. Rehabilitation therapists can help identify products that are certified by the manufacturer to meet this standard. Whenever possible a certified transit wheelchair should be used for school bus transportation.³ Research has provided a basis for recommendations concerning occupant securement for children who must ride in a wheelchair or children with other special needs who are transported on a school bus.^{1,4-6}

RECOMMENDATIONS

1. Any child who can assist with transfer or be reasonably moved from a wheelchair, stroller, or special seating device to a seat belt or child restraint system complying with FMVSS 213 (Child Restraint Systems) should be so transferred for transportation. The vehicle seat should be forward facing, equipped with dynamically tested occupant restraints, and provided for the vehicle at the point of manufacture. The unoccupied wheelchair also should be secured adequately in the vehicle to prevent it from becoming a dangerous projectile in the event of a sudden stop or crash.⁷
2. Passenger seats that have a seat belt or child restraint system attached should have a reinforced frame and meet the requirements of FMVSS 208 (Occupant Crash Protection), FMVSS 209 (Seat Belt Assemblies), and FMVSS 210 (Seatbelt Anchorages). The manufacturer of the school bus should be consulted regarding the noted requirements when ordering or retrofitting an existing school bus.⁸
3. All children weighing less than 50 lb should be secured in an appropriate child restraint or safety vest meeting the requirements of FMVSS 213.⁸

The recommendations in this statement do not indicate an exclusive course of treatment or serve as a standard of medical care. Variations, taking into account individual circumstances, may be appropriate.

PEDIATRICS (ISSN 0031 4005). Copyright © 2001 by the American Academy of Pediatrics.

4. Child safety seats or safety vests must be secured to the bus seat in a manner prescribed and approved by the manufacturer of the safety device. The child restraint should not be secured on a school bus seat adjacent to an emergency exit.
5. Child safety seats used to transport children who weigh less than 20 lb or are younger than 1 year should be attached to the school bus seat in a rear-facing position. A child restraint that is approved for rear facing for greater weights should be considered for a child who weighs 20 lb before 1 year of age.
6. Occupied wheelchairs should be secured in a forward-facing position.
7. Three-wheeled, cart-type units and other wheelchair or stroller-type devices should not be permitted for occupied transport in a school bus unless results of impact tests demonstrate that the device can be secured under impact loading conditions. Any wheelchair or stroller-type unit designed and approved by a manufacturer for transportation must be used according to manufacturer's instructions.
8. Wheelchairs should be secured with fastening devices that are attached to the floor. Any occupied wheelchairs should be secured with 4-point tie-down devices. These tie-down systems should be dynamically tested with a dummy the size of a 50th percentile adult male or with a dummy at the appropriate size for the type of wheelchair used. They must have demonstrated capabilities for restraining the wheelchair during a frontal impact with force conditions of 30 mph and 20g. The wheelchair securement system must not apply restraint to the occupant and should attach to the frame of the wheelchair rather than to the wheels. The occupant should be restrained to the wheelchair with a separate device.
9. Lap boards and metal or plastic trays attached to the wheelchair or to adaptive equipment should be removed before loading and should be secured separately for transport.
10. An occupant restraint system that has been tested at force conditions of 30 mph and 20g for upper torso restraint (ie, shoulder harness) and lower torso restraint (ie, lap belt over pelvis) should be provided for each wheelchair-seated occupant.
11. Any liquid oxygen transported in a school bus should be securely mounted and fastened to prevent damage and exposure to intense heat. An appropriate sign indicating that oxygen is in use should be placed in the school bus.

ADDITIONAL CONSIDERATIONS FOR PASSENGER TRANSPORTATION

The following considerations should be incorporated into the school system plan for the transportation requirements of children with special needs:

1. In accordance with state laws and regulations, a nurse or an aide with appropriate medical training can provide necessary on-board assistance

- and support to most children with tracheostomies who may require suctioning or emergency care during school bus transport. School systems should consider providing nurses or aides when medically necessary to help reduce the potential for respiratory and other related problems occurring while the children are on the school bus. This assistance should be included where appropriate in the child's Individual Education Plan (IEP) or the family's Individual Family Service Plan (IFSP).
2. School transportation staff should participate in the development of the transportation portion of the IEP or IFSP for children who may need special transportation requirements and medical procedures.
 3. School bus transportation staff should have annual access to training programs and resource material in special needs transportation to ensure that they can provide the most current and proper support to children with special transportation requirements. Transportation staff who work with children with special needs can carry out their daily responsibilities when provided with documented training from a team of professionals, including therapists, nurses, and certified child passenger safety technicians that ensures consistent and proper restraint for children with special needs on school buses.^{9,10}
 4. The caregiver (family, guardian, foster parent) of a child with special needs should be informed of the importance of incorporating appropriate and safe transportation specifications in the child's IEP or IFSP.
 5. The caregiver of a child with special needs and the designated bus driver for the child's bus route should share information addressing the specific needs of the child transported before and during the school year. An emergency medical information card should be kept on the bus for each student transported. Transportation personnel should adhere to the school district's policy regarding confidentiality of student information.
 6. School systems can help ensure optimum protection for children with special needs during school bus transport by establishing a written plan that outlines procedures for emergency evacuation for each child and by requiring, at the minimum, an evacuation drill for each school year that enables the transportation staff to practice evacuating children under their care. Local emergency response personnel should be invited to participate in evacuation drills.
 7. Children who are supported by technology may be at increased risk of acquiring infectious diseases. All caregivers should wash their hands before and after providing direct care for students including toileting, tracheostomy, or gastrostomy care. Standard (universal) precautions should be used when caring for all children when exposed to blood or blood-containing body fluids. Schools should follow the legal requirements of their states or the Occupational Safety and Health Administration (OSHA) with respect to all immunizations, including hepatitis B immunization. Chil-

dren and adults who are in the recommended categories should receive yearly influenza immunization.^{11,12} Transportation staff should be provided with training and supplies that prepare them to carry out universal precaution practices and procedures.¹⁰

The American Academy of Pediatrics encourages states to address and support the transportation requirements of children with special needs. Pediatricians can help their patients by being aware of general guidelines for evaluating restraint systems for children with special needs and remaining informed of new resources as they become available. Periodically updated information on specific restraint systems for children with special needs can be obtained through the Academy.¹³ In addition, pediatricians can play important roles at local and state levels to assist in the evaluation and development of school bus specifications responsive to the safe transportation requirements of children with special needs.

COMMITTEE ON INJURY AND POISON PREVENTION,
2000–2001

Marilyn J. Bull, MD, Chairperson
Phyllis Agran, MD, MPH
H. Garry Gardner, MD
Danielle Laraque, MD
Susan H. Pollack, MD
Gary A. Smith, MD, DrPH
Howard R. Spivak, MD
Milton Tenenbein, MD

LIAISONS

Ruth A. Brenner, MD, MPH
National Institute of Child Health and Human
Development
Stephanie Bryn, MPH
Health Resources and Services
Administration/Maternal and Child Health Bureau
Cheryl Neverman, MS
National Highway Traffic Safety Administration
Richard A. Schieber, MD, MPH
Centers for Disease Control and Prevention
Richard Stanwick, MD
Canadian Paediatric Society

Deborah Tinsworth
US Consumer Product Safety Commission

SECTION LIAISONS

Victor Garcia, MD
Section on Surgery
Robert R. Tanz, MD
Section on Injury and Poison Prevention

CONSULTANTS

Murray L. Katcher, MD, PhD
Larry K. Pickering, MD, FAAP

STAFF

Heather Newland

REFERENCES

1. National Highway Traffic Safety Administration Web site. Available at: <http://www.nhtsa.dot.gov/cars/rules/standards/safstanz.htm>
2. *National Standards for School Buses and National Standards for School Bus Operations*. Warrensburg, MO: Missouri Safety Center; 1995
3. WC-19 Voluntary Standard. Washington, DC: American National Standards Institute/Rehabilitation Engineering and Assistive Technology Society of North America; 1999
4. Schneider LW. *Protection for the Severely Disabled: A New Challenge in Occupant Restraint*. Proceedings of the International Symposium on Occupant Restraint. Morton Grove, IL: American Association for Automotive Medicine; 1981:217–231
5. Schneider LW. *Impact Sled Test Evaluation of Restraint Systems Used in Transportation of Handicapped Children*. Warrendale, PA: Society of Automotive Engineers; 1979. Technical Paper 790074
6. Wheelchair occupant restraint assemblies for use in motor vehicles. Standards Australia Amendment No. 1 to AS 2942–1994 (July 5, 1998)
7. Vehicles for transporting the handicapped. Indiana Code IAC No. 1–5.5 (February 1990)
8. *Guideline for the Safe Transportation of Pre-school Age Children in School Buses*. Washington, DC: National Highway Traffic Safety Administration; 1999
9. Stephens LL, Beekman LE, Munk LG, Stefans VA. *Study of Transportation of Medically Fragile Children: Core Curriculum for Special Education Transportation Health Care*. Lansing, MI: Michigan Department of Education; 1989:4
10. *Standardized Child Passenger Safety Training Program Participant Manual*. Washington, DC: National Highway Traffic Safety Administration; 2001. In press
11. American Academy of Pediatrics. In: Pickering LK, ed. *2000 Red Book: Report of the Committee on Infectious Diseases*. 25th ed. Elk Grove Village, IL: American Academy of Pediatrics; 2000:119–131
12. American Academy of Pediatrics, Committee on Infectious Diseases and Committee on Practice and Ambulatory Medicine. Infection control in physicians' offices. *Pediatrics*. 2000;105:1361–1369
13. American Academy of Pediatrics. *Car Seat Shopping Guide For Children With Special Needs: Guidelines for Parents*. Elk Grove Village, IL: American Academy of Pediatrics; 1998

Effective School Bus Occupant Restraints for Students with Special Needs

Susan Englert Shutrump O.T.R./L.
 Supervisor of Occupational and Physical Therapy Services
 Trumbull County Educational Service Center
 6000 Youngstown Warren Rd.
 Niles, Ohio 44446

Following are some specific concerns/problems often encountered when choosing occupant restraint systems for students with special needs. Equipment options that may provide assistance are given. Whenever possible, suggested equipment options are ranked from least restrictive (appropriate for children needing mild intervention) to most restrictive (for children needing more support or intervention). Important procedural considerations are noted for some problems. It is vital that these are given special attention by the team designing the student's individual transportation plan.

Problem/ CHALLENGE	EQUIPMENT OPTIONS	PROCEDURAL CONSIDERATIONS
1.Poor Head Control	<p>Child safety seat that is certified to be used rear facing (many are available for larger children)</p> <p>Child safety seat which allows recline in a forward facing position</p> <p>Neck collar -made of soft and light material and must be free floating</p> <p>Child safety seat designed for a child with special needs which incorporates a wedge/tilt</p> <p>Wheelchair or stroller which can be reclined with or without use of a collar</p>	<p>No straps or other positioning aids which secure the head or neck to the child safety seat separate from the torso should be used during transportation</p> <p>Most require use of a tether.</p> <p>Recline exceeding 30 degrees should be avoided. Shoulder belt anchor of WTOR may need to be moved rearward</p>

<p>2. Poor Trunk Control</p>	<p>Child safety seat with towel rolls placed along the child's torso to facilitate proper alignment</p> <p>Integrated child safety seat</p> <p>Bus seat with shoulder/lap belt or four point harness system</p> <p>Bus Specific Add-On Child Safety Restraint System</p> <p>Safety vest with crotch strap</p> <p>Modified E-Z-On Vest</p> <p>Child safety seat designed for a child with special needs which incorporates positioning pads</p>	<p>Positioning aids should be made of firm materials and cannot interfere with the working parts of the occupant restraint/child safety seat. No padding should be placed beneath or behind the child.</p> <p>Child must be older than 4 and be able to be properly fitted using only inherent adjustment features</p> <p>Entire seat behind must be unoccupied or seat a student also in CSRS</p> <p>Entire seat behind must be unoccupied or seat a student also in CSRS</p> <p>Child must be able to fit lengthwise on the vehicle seat. Vehicle floor space should be filled in with padding. Child's head must face towards aisle.</p> <p>Most require use of a tether.</p>
<p>3. Increased Leg Length/Lower Extremity Bulk/ Bulky LE Bracing Or Casting</p>	<p>Forward-facing only or combination child seat/booster used with internal harness</p>	<p>Caution must be exercised to assure that the seating area has adequate room for feet and legs. Feet should not be crammed against the seat back. Seat size must allow for the child to be placed easily</p>

Integrated child safety seat

in the seat (not forced). Children who wear bulky LE bracing or casting often experience sensory deficits, which make them prone to skin breakdown. In addition, their bones may be more brittle and prone to injury. The weight of the cast/braces must be accounted for when considering seat weight limits

Bus seat with shoulder/lap belt or four point harness system

Child must be older than 4 and be able to be properly fitted using only inherent adjustment features

Bus Specific Add-On Child Safety Restraint System

Safety vest with crotch strap

Entire seat behind must be unoccupied or seat a student also in CSRS

Child safety seat designed for a child with special needs with shorten sides and reduced seat bulk

Must have some hip flexion. Most require a tether

Modified E-Z-On Vest

Entire seat behind must be unoccupied or seat a student also in CSRS
Child must be able to fit lengthwise on the vehicle seat. Vehicle floor space should be filled in with

	<p>Wheelchair or stroller which can be reclined with or without use of wheelchair mounted safety vest</p>	<p>padding. Child's head should face towards aisle.</p> <p>Recline exceeding 30 degrees should be avoided. Shoulder belt anchor of WTOR may need to be moved rearward. Vest may need additional crotch straps</p>
<p>4. Need for Additional Lower Extremity Support</p>	<p>Positioning over the wheel well</p> <p>Child safety seat designed for a child with special needs, which incorporates a footplate</p>	<p>Most require use of a tether.</p>
	<p>5. Child with Behavioral Problems Who has Difficulty Staying in CSRS</p>	<p>Window seating with peer in aisle to cue proper behavior</p> <p>Harness properly fitted with jacket zipped over the Child Safety Restraint System buckle</p> <p>Safety vest with crotch strap</p>
		<p>IEP team to assure proper supervision and/or assistance must carefully analyze boarding procedures. Pictures of proper bus behavior mounted with Velcro or social stories may prompt compliance</p> <p>Allowing child to use headphones, books, or soft lightweight toys may help them stay seated and in CSRS.</p> <p>If the vest is necessary primarily because of problem behavior, a behavior intervention plan designed by the IEP Team should be in place that addresses the transportation environment. Entire seat behind must be unoccupied or seat a student</p>

<p>6. Child with a Shunt</p>	<p>Integrated child safety seat</p> <p>Bus seat with shoulder/lap belt or four point harness system which lacks buckles/hardware near shunt site</p> <p>Bus Specific Add-On Child Safety Restraint System</p>	<p>also in CSRS</p> <p>All equipment must provide support to the head and neck area.</p> <p>Child must be older than 4 and be able to be properly fitted using only inherent adjustment features</p> <p>Entire seat behind must be unoccupied or seat a student also in CSRS</p>
<p>7. Child with Tracheotomy</p>	<p>Child safety restraint system to provide upper torso restraint with well fitted harness</p>	<p>Seat placement in the front for maximum amount of adult supervision. Student should be positioned away from the lift door or open windows at the rear of the bus to avoid increased exposure to dust and fumes and/or frequent changes of temperature. Evaluate need for air conditioning.</p> <p>Oxygen if carried must be secured and mounted appropriately in the bus with guidance from the oxygen supplier/WTOR Manufacturer Emergency procedures to be followed in the event of respiratory distress should be clearly stated in the IEP with proper training and inservice given.</p>
<p>8. Child with Feeding Tube or ostomy bag</p>	<p>Child safety restraint systems which allow for adjustment in waist/pelvic area</p>	<p>All harness belts on equipment must avoid contact with the tube/ostomy site</p> <p>If child has difficulty</p>

<p>9. Child with Brittle Bones, Spinal Rods or Other Orthopedic Concerns for a Rough Ride</p>	<p>Seat placement in the front of the bus to allow for smoother ride.</p> <p>Avoid wheel well positions</p> <p>Transport on bus with air-ride</p>	<p>swallowing and may “pocket” food, a mouth check before boarding bus and seating in the front of the bus are recommended. Transport staff trained in airway check, Heimlich Maneuver, and moving student to firm surface.</p> <p>Additional padding may be necessary. The IEP team should meet to decide how to proceed. It is vital that all harness straps are properly positioned.</p>
<p>10. Child of Small Stature Who has Difficulty Getting Into and Out of the Bus</p>	<p>Step stool with non-slip step surface available at home and school if allowable</p> <p>Bus with additional steps</p>	<p>Children should not be carried onto or off of the bus.</p>

All equipment recommended should be installed and used in accordance with manufacturer instructions.

Some of the CSRS above can be installed on traditionally designed school buses and therefore may allow for an overall less restrictive transportation plan.

All procedures followed for preschool transportation should be consistent with the National Highway Traffic Safety Administration “Guideline for the Safe Transportation of Pre-school Age Children in School Buses”.

Any additional medical equipment or items accompanying the child should be secured appropriately in the vehicle

PEDIATRICS®

OFFICIAL JOURNAL OF THE AMERICAN ACADEMY OF PEDIATRICS

School Transportation Safety

Committee on Injury, Violence, and Poison Prevention and Council on School Health

Pediatrics 2007;120;213

DOI: 10.1542/peds.2007-1278

The online version of this article, along with updated information and services, is located on the World Wide Web at:

<http://pediatrics.aappublications.org/content/120/1/213.full.html>

PEDIATRICS is the official journal of the American Academy of Pediatrics. A monthly publication, it has been published continuously since 1948. PEDIATRICS is owned, published, and trademarked by the American Academy of Pediatrics, 141 Northwest Point Boulevard, Elk Grove Village, Illinois, 60007. Copyright © 2007 by the American Academy of Pediatrics. All rights reserved. Print ISSN: 0031-4005. Online ISSN: 1098-4275.

American Academy of Pediatrics

DEDICATED TO THE HEALTH OF ALL CHILDREN™





School Transportation Safety

Committee on Injury, Violence, and Poison Prevention and Council on School Health

Organizational Principles to Guide and Define the Child Health Care System and/or Improve the Health of All Children

ABSTRACT

This policy statement replaces the previous version published in 1996. It provides new information, studies, regulations, and recommendations related to the safe transportation of children to and from school and school-related activities. Pediatricians can play an important role at the patient/family, community, state, and national levels as child advocates and consultants to schools and early education programs about transportation safety.

INTRODUCTION

School transportation plays a consistent and long-term role in the lives of children from preschool through high school. Pediatricians can participate by serving as resources, educators, consultants, and advocates for school transportation safety at the local, state, and federal levels. This revised policy statement provides updated recommendations that can enhance community systems for addressing safe transportation for children to and from school and school-related activities.

Expectations for school transportation and school bus safety should be upheld in an ongoing commitment from communities and states to ensure that children travel to and from school safely. The National Highway Traffic Safety Administration (NHTSA) School Bus Safety Program is committed to reducing school bus crashes, injuries, and fatalities.¹ Congress has indicated that school transportation should be held to the highest level of safety.² In addressing school transportation, all modes of travel must be considered, and measures must be taken to promote safety for each mode.

Modes of School Transportation

The Committee on School Transportation Safety of the Transportation Research Board studied the various modes of travel and associated risks for schoolchildren.³ Estimates of trips per year by mode of transportation during school hours were: passenger vehicle with adult driver, 45%; school buses, 25%, other buses, 2%; passenger vehicle with teen driver, 14%; bicycle, 2%; and walking, 12%. These estimates are limited, because they do not include school bus travel for extracurricular activities during or after normal school hours or during vacations. School bus crashes occur disproportionately on high-speed roads at night during transportation to and from extracurricular activities.⁴

Annually during normal school travel hours, 23.5 million children are transported on 457 000 school buses, totaling 5.8 billion student trips and 3.13 billion miles.⁵ Each child who uses school bus transportation travels, on average, 1300 miles per school year. These estimates do not include school or school-related travel during nonschool hours.

www.pediatrics.org/cgi/doi/10.1542/peds.2007-1278

doi:10.1542/peds.2007-1278

All policy statements from the American Academy of Pediatrics automatically expire 5 years after publication unless reaffirmed, revised, or retired at or before that time.

Key Words

school transportation, school bus, travel on school bus, getting to and from school

Abbreviations

NHTSA—National Highway Traffic Safety Administration

NTSB—National Transportation Safety Board

FMVSSs—federal motor vehicle safety standards

AAP—American Academy of Pediatrics

PEDIATRICS (ISSN Numbers: Print, 0031-4005; Online, 1098-4275). Copyright © 2007 by the American Academy of Pediatrics

School Transportation Injury

Annually, there are, on average, 815 student deaths and 152 250 injuries related to school travel during normal school travel hours. (These data are underestimates, because they do not include school-related trips or school bus crashes outside of school hours, and reporting is voluntary.) Two percent of the deaths and 4% of the injuries occurred in school buses. Seventy-five percent of the deaths and 84% of the injuries occurred in passenger vehicles. The fatality rates descend in the following order: (1) passenger vehicles with teen drivers, 55%; (2) passenger vehicles with adult drivers, 20%; (3) walking (pedestrians), 16%; (4) bicyclists, 6%; and (5) school and other buses, 2%. The injury rates descend in the following order: (1) passenger vehicles with teen drivers, 51%; (2) passenger vehicles with adult drivers, 33%; (3) walking (pedestrian), 6%; (4) bicycles, 5%; and (5) school and other buses, 5%.³

The Fatality Analysis Reporting System⁶ includes fatality data on all school bus-related crashes, not just those during school hours. In the year 2001, 141 persons were killed. Of the fatalities, 16% were pedestrians, 9% were school bus passengers, 4% were school bus drivers, 3% were bicyclists, and the rest (68%) were occupants of other vehicles or other nonmotorists. Of the 22 child pedestrian fatalities, 82% were struck by the school bus. Data from the General Estimates System indicate that 13 000 persons are injured annually in school bus crashes.⁷ Of those injured, 46% (5980) were school bus occupants, 8% were school bus drivers, 38% were occupants of other vehicles, and fewer than 0.05% each were pedestrians, pedal cyclists, and nonmotorists.⁸ However, the National Transportation Safety Board (NTSB) determined that school bus crash data are incomplete and that injuries cannot be reliably estimated.⁹ The first emergency department-based study of nonfatal school bus-related injuries found that the number of injuries (17 000 annually to children 0–19 years of age) greatly exceeded previously published estimates. Motor vehicle crashes were the most frequent injury mechanism.¹⁰

RECOMMENDATIONS

School Bus Travel

The National Traffic and Motor Vehicle Safety Act of 1966 and the upgrades in the School Bus Safety Amendments of 1974 authorize the Department of Transportation to issue minimum standards for new school buses manufactured for sale in the United States.¹¹ There are 35 federal motor vehicle safety standards (FMVSSs) that apply to school buses. Large school buses that carry more than 16 passengers are not required to be equipped with seat belts. The long-standing American Academy of Pediatrics (AAP) recommendation that seat belts be installed on all new school buses is further discussed later in this statement. Small school buses (weighing <10 000

pounds) built in accordance with FMVSSs are equipped with lap belts. Vehicles, including multipurpose vehicles that carry 11 or more persons that are sold or leased for transporting students to or from school or school-related events, are required to meet the FMVSS requirements applicable to school buses. States may prescribe additional regulations that apply to the use of any vehicle used to transport preprimary, primary, and secondary school students.¹²

The AAP recommends that all guidelines for safe transportation of all preschool- and school-aged children be applied during all school and school-related trips regardless of the hours of operation.

Preschool-Aged Children

Many school systems provide transportation for preschool-aged children. The NHTSA studies demonstrated that preschool-aged children were safest when properly transported in child safety restraint systems that meet FMVSSs 213 and 225.¹³ In January 2001, the Department of Health and Human Services issued transportation safety requirements for Head Start transportation. Within 5 years, transportation was limited to school buses or “allowable alternate vehicles.” This provision has since been extended to June 30, 2007. That is, on July 1, 2007, all Head Start children must be transported in a compliant vehicle, unless a waiver has been granted. All vehicles must be equipped with a communication system for emergencies, first aid kit, fire extinguisher, and seat belt cutter. Children weighing 50 pounds or less were required to travel in FMVSS 213–approved child restraints; this has since been updated to apply to children under the weight threshold of FMVSS 213 for approved child restraints (currently 65 pounds). As of January 2004, vehicles must be equipped to use child restraints. Retrofit of lap belts or child-restraint anchorage to properly secure the child safety restraint system to the school bus seat is allowed and must be reinforced according to the applicable FMVSS.¹³ The driver must have a commercial driver’s license and undergo criminal background checks. As of January 2004, all vehicles must have a bus monitor. Each Head Start agency is required to provide pedestrian-safety education for parents and children. An extension to January 18, 2006, for implementation of the requirement to provide car safety seats and bus monitors was allowed for Head Start programs that filed an application by April 1, 2004. A final rule was published on October 4, 2006, authorizing the Department of Health and Human Services to issue waivers from this requirement to Head Start grantees. The NHTSA has a curriculum for child passenger safety technicians, materials available regarding proper use of child safety restraint systems in school buses, and child passenger training materials for school bus drivers.

The AAP has recommended and advocated that school districts provide height- and weight-appropriate

car safety seats and restraint systems that meet FMVSSs for all preschool-aged children. These systems include booster seats for which a 3-point belt is available for installation. The AAP also supports the Head Start transportation safety requirements.

The AAP further recommends that school-based as well as non-school-based child programs follow guidelines for safe transportation. This includes all early education and child care programs and applies to car-pool transportation as well. The AAP Moving Kids Safely in Child Care program is the first national occupant-protection curriculum for child care providers and administrators; it provides detailed guidelines for safe transportation of all children.¹⁴

School-Aged Children: Occupant Protection on School Buses

Compartmentalization has been the occupant-protection system for children in large school buses for more than 30 years and was the only available protection before child-restraint systems and seat belts were available for use in the school bus environment. Compartmentalization is provided by seats that are closely spaced with high, energy-absorbing seat backs. Data from real-world crashes comparing seat belt use versus compartmentalization only do not exist. However, recent studies have revealed that compartmentalization does not offer optimal protection and is not consistent with current technology and messages for children and families regarding the use of car safety seats and seat belts in all motor vehicles.^{9,15,16}

The NTSB, through a series of crash investigations, determined that compartmentalization as a method of occupant protection on school buses is incomplete. Compartmentalization does not provide protection during lateral (side) impacts with vehicles of large mass or in rollover collisions, because passengers do not always remain completely within the compartment. The NTSB recommended the development and implementation of a seat and restraint system that restrains passengers in the seating compartment. The NTSB also recommended the development of performance standards and requirements for school bus occupant-protection systems on newly manufactured school buses. The NTSB further recommended on-board recording devices to facilitate improved data collection in crashes.⁹ For optimal protection of all children, the AAP concurs with these recommendations.

The NHTSA conducted a study of school bus occupant protection in 2000 and determined that lap/shoulder belts on school buses performed best in dummy crash-testing compared with unbelted occupants, compartmentalization, and lap belts. Head-injury measurements were significantly lower with use of lap/shoulder belts than for use of compartmentalization or lap belts. In crash tests, the lap/shoulder belt restraint systems effectively kept the dummies in their seats.¹⁶

The State of California Vehicle Code requires newly manufactured school buses to have a lap/shoulder belt restraint system, effective 2004 for small school buses and 2005 for large school buses.¹⁷ At the time of this publication, the states of Florida, Louisiana, New Jersey, and New York and many local school districts have passed school bus seat belt laws.¹⁸

The AAP recommends that all children travel in age-appropriate, properly secured child-restraint systems when transported in all motor vehicles, including school buses, to ensure the safest ride possible. The AAP further recommends that all newly manufactured school buses be equipped with lap/shoulder restraint systems that can also accommodate car safety seats, booster seats, and harness systems. The AAP recognizes the added benefit of improved student behavior and consistent habits of restraint use when traveling in motor vehicles. Policies on seat belt use have been found to improve student behavior and reduce driver distraction.^{4,19,20} School districts must ensure the appropriate education of administrators, students, teachers, drivers, and parents in the use of occupant-protection devices.

School Bus Safety Features

The AAP recommends that all school buses, including private, parochial, and contractual, that are used for school and all school-related activity transportation be in compliance with all applicable federal regulations. Buses built before 1977 should be retired from use, because they are deficient in several significant safety standards.⁴

Effective December 2, 1993, the FMVSSs were revised to require mirrors to improve driver visibility in front of and along both sides of school buses.²¹ In addition, districts should consider installing strobe lights for use during reduced-visibility conditions, an external loud-speaker system to enable the driver to communicate with children outside the bus, and loading and backing alarms or pulsating backup horns.²² School bus blind areas created by school bus bodies or mirrors are considerable.²³ Electronic sensor systems are available but have not been evaluated adequately to determine their effectiveness.⁴ The AAP recommends that blind spots created by mirror systems and other vehicle-design aspects should be addressed by improved technology designed to decrease both crash and pedestrian injury risks because of limited visibility of a child by the bus driver.

The Children's School Bus Exposure Study, prepared for the California Air Resources Board, found that diesel buses can have significantly higher on-board diesel-related pollutant concentrations than other vehicles because of intrusion of the bus's own exhaust into the cabin.²⁴ Increased exposure from commuting by school bus was estimated to increase a child's lifetime cancer risk by approximately 4%, increase the incidence of lower respiratory symptoms by approximately 6%, and increase daily hospitalizations for asthma by approxi-

mately 1%. Several states and local governments have adopted airborne toxic control measures that limit school bus idling and idling at schools.^{25,26} Bus idling also contributes to poor indoor air quality inside schools from unfiltered air that enters through open doors. The AAP recommends that states adopt measures to protect school-aged children from exposure to toxic air contaminants.²⁷ Additional measures to reduce children's exposure to vehicle-related pollutants include replacement of older buses, use of alternate-fueled or particulate-trap-equipped buses, retrofitting buses with better emission-control technologies, minimizing bus caravanning, use of cleaner buses on longer routes, having passengers sit at the front of the bus if it is not full, and minimizing idling.^{24,28}

School Bus Transportation of Children With Special Medical Needs

Children with special needs and who are older than the preschool-aged child and require special restraint systems should be evaluated individually to determine the most appropriate system that meets their needs for positioning during travel, regardless of their age, weight, and height. Specific recommendations are outlined in the AAP policy statement on school bus transportation of children with special needs.²⁹

The use of wheelchairs is common for school bus transportation of children with disabilities. The AAP recommends that states adopt the requirements for use of wheelchairs on school buses outlined in the 1995 National Standards for School Buses²² and the AAP policy statement on school bus transportation of children with special needs.²⁹

School Bus Driver Selection, Training, and Performance

The Transportation Research Board stated that variations in school bus driver recruitment, selection, training practices, and rates of pay are likely to be associated with variations in driver safety performance.³ In another report, the Transportation Research Board recommended that all states provide formal training for school bus drivers, including training on school bus driver responsibility in ensuring safety of the children inside the bus and in loading zones.⁴

The AAP believes that national standards for the selection, training, and regulation of school bus drivers should be established and implemented to ensure optimal driver performance.

To meet basic requirements, school bus drivers should:

- maintain a valid commercial driver's license;
- be at least 21 years of age;
- show proof of an annual health history, assessment, and physical examination, including vision and hearing assessments, that document the absence of condi-

tions that may compromise driving and child supervision;

- successfully complete a written or oral test covering driver duties, bus-operating procedures, traffic and school bus laws and regulations, record keeping, emergency and crash-related procedures, first aid, basic appreciation of the developmental stages and needs of preschool and school-aged children, child-supervision responsibilities, and transportation of passengers with special needs;
- maintain a satisfactory driving record as determined by the school district;
- successfully pass a review for a criminal record (including convictions of child sexual abuse and incidents or arrests for driving under the influence of alcohol or other drugs) that is reviewed annually; and
- pass a test for illicit drugs and alcohol as required by the district (mandatory testing is recommended if it is not already required).

To demonstrate operational and driving skills, school bus drivers should:

- pass a driving performance test and demonstrate safe loading and unloading procedures;
- demonstrate physical capability to successfully accomplish student evacuation; and
- demonstrate correct use of all occupant-protection systems that may be available on the school bus, including use of car safety seats, seat belt systems, and occupant-protection systems that are used by children with special medical or health needs.

Children with conditions such as anaphylactic allergies, severe asthma, diabetes, attention-deficit/hyperactivity disorder, autism or pervasive developmental disorder, and other chronic conditions may have health and safety issues during transport to and from school and school-related events. For that reason, the following are important:

- Drivers should be included in school plans for children with special medical and transportation needs.
- School bus drivers need to be aware of and prepared to intervene appropriately to ensure the safety of the individual child as well as all children on the trip. Interventions may require training beyond basic first aid.

School Bus Passenger Instruction

Passengers of all ages need to be taught safe riding and pedestrian behavior regardless of the frequency of school bus use. Instruction should include safe pedestrian practices going to and from the bus stop; safe behavior while waiting for the bus; safe practices for boarding and dis-

embarking the bus; safe behavior on the bus, including the use of child-restraint systems and seat belts when present; and procedures for emergency situations. Escort services for children crossing streets and roads should be considered.³⁰

School Bus Passenger Supervision

Adult supervision on school buses should focus on ensuring that passengers stay seated and use age-appropriate car safety seats, seat belts, and other occupant-protection systems; ensuring that passengers keep their arms and heads inside the windows; assisting in emergency circumstances; assisting passengers with special needs; and escorting children across roadways. A second adult (other than the driver) serving as a monitor on the school bus can best meet these objectives. The Transportation Research Board states that it is generally agreed that monitors would enhance safety and reduce injuries by 25% to 75%; however, the cost estimate is high (\$1.9 billion).⁴

School Bus Routes and Stops

Bus routes should be planned so that the bus does not have to back up, traffic disruptions are minimized, good fields of vision are provided at all stops, and the need for children to cross a street to board or leave the bus is minimized.⁴ Escorting children across streets has the greatest potential for injury reduction.⁴ Roads, traffic flow, traffic-control devices, and speed-limit enforcement should be maintained to optimize the safety of children.

Bicyclist and Pedestrian Travel to and From School

The motor, cognitive, and behavioral characteristics and abilities and limitations of children of different ages must be considered when assessing supervision needs necessary for students walking to and from school. There is no evidence that generic pedestrian-safety education is effective in reducing pedestrian injury. Bicyclists should be required to wear bicycle helmets properly.³¹ Children using nonmotorized vehicles for school and school-related trips should be required to use safety equipment, including helmets.³² Bicycle helmet use laws and enforcement increase helmet use.³³ Driver education in school zones, including drivers who drop off and pick up students, must be addressed. Most drivers exceed speed limits in school zones.³⁴ Safe Routes to School, an international movement, promotes infrastructure, environmental measures, enforcement, policy change, and education to enhance and promote safe walking.³⁵

School-Zone Improvements

School-zone improvements would enhance the safety of all schoolchildren whether they walk, bike, take the school bus, or are dropped off and picked up with a passenger vehicle. These measures include marked drop-off and pick-up areas that are separate from school buses, school-zone speed-limit enforcement at 25 miles/

hour, development of safe routes to school, and well-trained adult crossing guards. Crossing guards have been effective in improving pedestrian safety and have improved speed compliance and traffic control.³⁶ The NHTSA issued guidelines for a uniform approach for traffic controls for school areas that were designed to enhance the safety of pedestrians. These guidelines further recommend that a school-route travel plan be developed systematically by school, law enforcement, and traffic officials.³⁷ A multidisciplinary approach, involving school administrators, parent-teacher organizations, city planners, and law enforcement that includes infrastructure design as well as education of both students and drivers, offers potential to decrease death and injury to children in school zones.³⁸

The AAP recommends the implementation of measures to improve the environmental infrastructure, including student supervision and crossing guards.

The Pediatrician's Role

The pediatrician should promote school transportation safety at 4 levels: patient and family, community, state, and national. Pediatricians can serve as child advocates and consultants to child care and schools about transportation safety.

For school bus travel, the AAP emphasizes its longstanding position that seat belts be installed on all newly manufactured school buses. Three-point seat belts provide the best protection for school-aged children who have outgrown car safety seats.

Patient and Family Counseling

1. When addressing child passenger safety, inform families that the AAP has guidelines and policy statements for safe transportation of schoolchildren in school buses and other vehicles used for preschool, school, and child care transportation. In particular, inform parents that the AAP recommends that all children who travel in school buses use age- and size-appropriate child-restraint systems and 3-point seat belts when they have outgrown child-restraint systems. Pediatricians should nevertheless counsel parents that large school buses, even when not equipped with seat belts, are the safest mode of school transportation.
2. Inform patients and families about the importance of bicycle helmets and other safety measures for children riding bicycles.
3. Inform parents that teens traveling together, especially with a teen driver, to and from school and to school-related events are at high risk of crash involvement and injury.
4. Promote passage and parent and community enforcement of graduated driver licensing laws, which

reduce fatal crash involvement of 16-year-old drivers by 16% to 21%.^{39,40}

Community Role

5. Serve as a consultant to local parent groups, transportation directors, or school boards on the physical, cognitive, and psychosocial development of children as related to school transportation. Provide AAP guidelines and policy statements related to school transportation and teen driving.
6. Provide resources for communities to address safe routes for children who walk or bike to school.
7. Promote mandatory requirements for children to use bicycle helmets.
8. Advocate implementation of the recommendations of applicable policy statements at local school district meetings. Advocate for school districts to enforce graduated driver licensing laws.
9. Work with communities to plan for the transportation of children in planning new school sites and modifying existing sites.
10. Advocate for 3-point seat belt systems in all newly manufactured school buses

State Role

11. Serve as a consultant to state directors of school transportation to ensure that children's needs and AAP guidelines are addressed in school transportation plans.
12. Advocate for mandatory bicycle helmet use laws and enforcement.
13. Share information from AAP policy statements.
14. Serve as a resource and consultant to the state department of education regarding training of bus drivers in areas relating to child passenger safety and child development and behavior.
15. Serve as a resource and consultant to the state department of education on pedestrian and bicycle safety for schoolchildren.

National Role

16. Encourage research to support continued improvement in school bus design and school-zone safety.
17. Advocate for mandated complete collection and reporting of data on fatalities and injuries by school districts and school bus transportation companies for all crash and noncrash events involving the school bus and multipurpose vehicles.

COMMITTEE ON INJURY, VIOLENCE, AND POISON PREVENTION, 2005–2006

Gary A. Smith, MD, DrPH, Chairperson
Carl R. Baum, MD
M. Denise Dowd, MD, MPH

Dennis R. Durbin, MD, MSCE
H. Garry Gardner, MD
Robert Sege, MD, PhD
Michael S. Turner, MD
Jeffrey C. Weiss, MD
Joseph L. Wright, MD, MPH

PAST COMMITTEE MEMBERS

Marilyn J. Bull, MD
*Phyllis F. Agran, MD, MPH

LIAISONS

Ruth A. Brenner, MD, MPH
National Institute of Child Health and Human
Development
Stephanie Bryn, MPH
Health Resources and Services
Administration/Maternal and Child Health Bureau
Julie Gilchrist, MD
Centers for Disease Control and Prevention
Alexander "Sandy" Sinclair
National Highway Traffic Safety Administration
Jonathan D. Midgett, PhD
US Consumer Product Safety Commission
Lynne J. Warda, MD
Canadian Paediatric Society

STAFF

Rebecca Levin-Goodman, MPH

COUNCIL ON SCHOOL HEALTH, 2005–2006

Barbara Frankowski, MD, MPH, Chairperson
Rani S. Gereige, MD, MPH
Cynthia J. Mears, DO
Robert D. Murray, MD
Michele M. Roland, MD
Thomas L. Young, MD
Linda M. Grant, MD, MPH
Daniel Hyman, MD
Harold Magalnick, MD
George J. Monteverdi, MD
Evan G. Pattishall, III, MD

LIAISONS

Nancy LaCursia, PhD
American School Health Association
Donna Mazyck, MS, RN
National Association of School Nurses
Mary Vernon-Smiley, MD, MPH
Centers for Disease Control and Prevention
Robin Wallace, MD
Independent School Health Association

STAFF

Su Li, MPA

*Lead author

REFERENCES

- National Highway Traffic Safety Administration. School bus safety program. Available at: www.nhtsa.dot.gov/portal/site/nhtsa/menuitem.e712547f8daccabbf30811060008a0c. Accessed October 3, 2005
- Motor Vehicle and School Bus Safety Amendments. Pub L No. 93-492 (1974)
- National Academies, National Research Council, Transportation Research Board, Committee on School Transportation Safety. *The Relative Risks of School Travel: A National Perspective and Guidance for Local Community Risk Assessment*. Washington, DC: National Academies; 2002. Special Report 269
- National Academies, National Research Council, Transportation Research Board. *Improving School Bus Safety*. Washington, DC: National Research Council; 1989. Special Report 222
- Bobit Business Media. *School Bus Fleet 2003 Fact Book*. Torrance, CA: Bobit Publishing; 2003
- National Highway Traffic Safety Administration, National Center for Statistics and Analysis. Fatality Analysis Reporting System (FARS) Web-based encyclopedia. 2002. Available at: www-fars.nhtsa.dot.gov. Accessed May 3, 2007
- National Highway Traffic Safety Administration, National Center For Statistics and Analysis. *General Estimates System*. Washington, DC: US Department of Transportation; 2002
- National Highway Traffic Safety Administration, National Center for Statistics and Analysis. *Traffic Safety Facts 2001: A Compilation of Motor Vehicle Crash Data From the Fatality Analysis Reporting System and the General Estimates System*. Washington, DC: US Department of Transportation; 2002
- National Transportation Safety Board. *Bus Crashworthiness Special Investigation Report*. Washington, DC: National Transportation Safety Board; 1999. Publication PB99-917006 NTSB/SIR-99/04
- McGeehan J, Annest JL, Vajani M, Bull MJ, Agran PE, Smith GA. School bus-related injuries among children and teenagers in the United States, 2001–2003. *Pediatrics*. 2006;118:1978–1984
- National Highway Traffic Safety Administration. *School Bus Vehicle Safety Report*. Report of the Secretary of Transportation to the United States Congress Pursuant to Section 103 of the 1976 Amendments to the National Traffic and Motor Vehicle Safety Act of 1966. Washington, DC: US Government Printing Office; 1977. Publication DOT HS-802 191
- National Highway Traffic Safety Administration. Use of nonconforming vehicles for school transportation. Available at: www.nhtsa.dot.gov/people/injury/buses/pub/noncom.hmp.html. Accessed October 3, 2005
- National Highway Traffic Safety Administration. *Guideline for the Safe Transportation of Pre-school Age Children in School Buses*. Washington, DC: US Department of Transportation; 1999
- American Academy of Pediatrics, Healthy Child Care America. *Moving Kids Safely in Child Care*. Elk Grove Village, IL: American Academy of Pediatrics; 2002
- American Academy of Pediatrics, Committee on Injury and Poison Prevention. Selecting and using the most appropriate car safety seats for growing children: guidelines for counseling parents. *Pediatrics*. 2002;109:550–553
- National Highway Traffic Safety Administration. *Report to Congress: School Bus Safety—Crashworthiness Research*. Washington, DC: US Department of Transportation; 2002
- State of California, Department of Motor Vehicles. Vehicle Code §27316
- National Conference of State Legislatures. Transportation reviews: school bus safety. Available at: www.ncsl.org/programs/transportation/schbussa.htm. Accessed May 22, 2007
- Boces MO; New York State Education Department. *Seat Belts and School Buses*. Albany, NY: New York State Education Department; 1994
- New York State Education Department. *1997 Survey of Public School Districts: Seat Belts on School Buses*. Albany, NY: New York State Education Department; 1997
- National Highway Traffic Safety Administration. *Federal Motor Vehicle Safety Standards and Regulations: Standard 111 (1993)*. Washington, DC: US Department of Transportation; 1993. Available at: www.nhtsa.dot.gov/cars/rules/import/FMVSS/#SN111. Accessed October 3, 2005
- National Conference on School Transportation. National Standards for School Buses and School Bus Operations. Revised ed. Warrensburg, MO: Missouri Safety Council, Central Missouri State University; 1995
- California Department of Education. *School Bus Blind Areas*. Sacramento, CA: California Department of Education; 2003
- Fitz DR, Winer AM, Colome S. Characterizing the range of children's pollutant exposure during school bus commutes. 2003. Available at: www.arb.ca.gov/research/schoolbus/execsum.pdf. Accessed October 3, 2005
- California Code of Regulations. Airborne Toxic Control Measure to Limit School Bus Idling and Idling at Schools. §2480, Title 13 (2003)
- Air Resources Board, State of California. Appendix B: summary of anti-idling regulations in other states. In: *California Air Toxics Program*. Sacramento, CA: Air Resources Board, State of California; 2002. Available at: www.arb.ca.gov/toxics/sbidling/appb.doc. Accessed October 3, 2005
- Kim JJ; American Academy of Pediatrics Committee on Environmental Health. Ambient air pollution: health hazards to children. *Pediatrics*. 2004;114:1699–1707
- US Environmental Protection Agency. Clean school bus USA. Available at: www.epa.gov/otaq/schoolbus. Accessed October 3, 2005
- American Academy of Pediatrics, Committee on Injury and Poison Prevention. School bus transportation of children with special health care needs. *Pediatrics*. 2001;108:516–518
- State of California, Department of Motor Vehicles. Vehicle Code 22112
- American Academy of Pediatrics, Committee on Injury, Violence, and Poison Prevention. Bicycle helmets. *Pediatrics*. 2001;108:1030–1032
- American Academy of Pediatrics, Committee on Injury and Poison Prevention. Skateboard and scooter injuries. *Pediatrics*. 2002;109:542–543
- Schieber RA, Gilchrist J, Sleet DA. Legislative and regulatory strategies to reduce childhood unintentional injuries. *Future Child*. 2000;10:111–136
- National Safe Kids Campaign. *Child Pedestrians at Risk in America: A National Survey of Speeding in School Zones*. Washington, DC: National Safe Kids Campaign; 2000. Available at: www.usa.safekids.org/wtw/documents/Research00.pdf. Accessed October 3, 2005
- State of California EPIC, Epidemiology and Control for Injury Control Branch. Safe routes to school. Available at: www.dhs.ca.gov/routes2school. Accessed October 3, 2005
- Federal Highway Administration. *A Review of Pedestrian Safety Research in the United States and Abroad*. Washington, DC: US Department of Transportation; 2004. Publication FHWA-RD-03-042. Available at: www.walkinginfo.org/rd/safety.cfm#pedsynth. Accessed May 3, 2007
- Federal Highway Administration. *Part 7: Traffic Controls for School Areas—MUTCD 2000 Manual on Uniform Traffic Control Devices*. Millennium ed. Washington, DC: US Department of Transportation; 2000. Available at: <http://mutcd.fhwa.dot.gov/pdfs/millennium/06.14.01/7ndi.pdf>. Accessed May 3, 2007
- State of California, Office of Traffic Safety and Safe Routes to

- School Initiative, California Department of Health Services. *Transportation Tools to Improve Children's Health and Mobility*. Sacramento, CA: California Department of Health Services; 2002. Available at: www.lgc.org/freepub/PDF/Land_Use/fact_sheets/sr2s_transportation_tools.pdf. Accessed May 3, 2007
39. Chen LH, Baker SP, Li G. Graduated driver licensing programs and fatal crashes of 16-year-old drivers: a national evaluation. *Pediatrics*. 2006;118:56–62
40. Weiss JC; American Academy of Pediatrics, Committee on Injury, Violence, and Poison Prevention, Committee on Adolescence. The teen driver. *Pediatrics*. 2006;118:2570–2581

RESOURCE LIST

- American Academy of Pediatrics, American Public Health Association, National Resource Center for Health, Safety in Child Care. *Caring for Our Children: National Health and Safety Performance Standards—Guidelines for Out-of-Home Child Care Programs*. Elk Grove Village, IL: American Academy of Pediatrics; 2002 [Guidelines for transportation of children are given.]
- American Academy of Pediatrics, Healthy Child Care America. *Moving Kids Safety in Child Care*. Elk Grove Village, IL: American Academy of Pediatrics; 2002 [A curriculum for child care providers and administrators that covers seat restraints, route planning, air bag safety, car safety seats, booster seats, and more is provided.]
- American Academy of Pediatrics. *Safe Transportation of Children With Special Needs: A Guide for Families*. Elk Grove Village, IL: American Academy of Pediatrics; 2002 [Information applicable to the safe transportation of children with special needs is provided.]
- US Department of Transportation, Federal Highway Administration. Safe routes to school Web site. Available at: <http://safety.fhwa.dot.gov/saferoutes> [The goal of Safe Routes to School is to empower communities to get more children traveling safely to school on foot or bike with greater frequency. Available resources include, but are not limited to, information on federal funding, state contacts, and links to other Web sites including the National Safe Routes to School Clearinghouse.]
- International Walk to School Web site. Available at: www.iwalktoschool.org
- US Environmental Protection Agency. Clean school bus USA. Available at: www.epa.gov/otaq/schoolbus [provides clinicians and communities information on how to reduce pollution caused by school buses]

Updated Information & Services	including high resolution figures, can be found at: http://pediatrics.aappublications.org/content/120/1/213.full.html
References	This article cites 9 articles, 8 of which can be accessed free at: http://pediatrics.aappublications.org/content/120/1/213.full.html#ref-list-1
Citations	This article has been cited by 2 HighWire-hosted articles: http://pediatrics.aappublications.org/content/120/1/213.full.html#related-urls
Subspecialty Collections	This article, along with others on similar topics, appears in the following collection(s): Community Pediatrics http://pediatrics.aappublications.org/cgi/collection/community_pediatrics_sub School Health http://pediatrics.aappublications.org/cgi/collection/school_health_sub Committee on Injury, Violence, and Poison Prevention http://pediatrics.aappublications.org/cgi/collection/committee_on_injury_violence_and_poison_prevention Council on School Health http://pediatrics.aappublications.org/cgi/collection/council_on_school_health Injury, Violence & Poison Prevention http://pediatrics.aappublications.org/cgi/collection/injury_violence_-_poison_prevention_sub
Permissions & Licensing	Information about reproducing this article in parts (figures, tables) or in its entirety can be found online at: http://pediatrics.aappublications.org/site/misc/Permissions.xhtml
Reprints	Information about ordering reprints can be found online: http://pediatrics.aappublications.org/site/misc/reprints.xhtml

PEDIATRICS is the official journal of the American Academy of Pediatrics. A monthly publication, it has been published continuously since 1948. PEDIATRICS is owned, published, and trademarked by the American Academy of Pediatrics, 141 Northwest Point Boulevard, Elk Grove Village, Illinois, 60007. Copyright © 2007 by the American Academy of Pediatrics. All rights reserved. Print ISSN: 0031-4005. Online ISSN: 1098-4275.

American Academy of Pediatrics

DEDICATED TO THE HEALTH OF ALL CHILDREN™



School Transportation Safety
Committee on Injury, Violence, and Poison Prevention and Council on School Health
Pediatrics 2007;120;213
DOI: 10.1542/peds.2007-1278

PEDIATRICS is the official journal of the American Academy of Pediatrics. A monthly publication, it has been published continuously since 1948. PEDIATRICS is owned, published, and trademarked by the American Academy of Pediatrics, 141 Northwest Point Boulevard, Elk Grove Village, Illinois, 60007. Copyright © 2007 by the American Academy of Pediatrics. All rights reserved. Print ISSN: 0031-4005. Online ISSN: 1098-4275.

American Academy of Pediatrics

DEDICATED TO THE HEALTH OF ALL CHILDREN™



Ride Safe

Information to help you travel more safely
in motor vehicles while seated in your wheelchair



www.travelsafer.org

www.rercwts.org

When traveling in a motor vehicle, it is generally safest for wheelchair users to transfer to a vehicle seat and use the vehicle seatbelt system or a child safety seat that complies with federal safety standards. The wheelchair should then be stored and secured in the vehicle.

If transferring is not feasible, it is very important to secure the wheelchair to the vehicle facing forward and to use crash-tested seatbelts for the wheelchair-seated rider.

1 START WITH THE RIGHT EQUIPMENT

The Wheelchair

▼ It is best if you have a wheelchair that has been designed and tested for use as a seat in motor vehicles, often referred to as a **WC19 wheelchair or a transit wheelchair**. These wheelchairs comply with ANSI/RESNA WC19, a voluntary standard developed by safety and rehabilitation experts. Wheelchairs that meet the design and performance requirements of this standard will be labeled to show that they comply with WC19.

▼ Most importantly, a WC19 wheelchair has four, crash-tested securement points where tiedown straps and hooks can be easily attached. These points are clearly marked with a hook symbol.

▼ If a WC19 wheelchair is not available, the next best choice is a wheelchair with an accessible metal frame where tiedown straps and hooks can be attached at frame junctions.

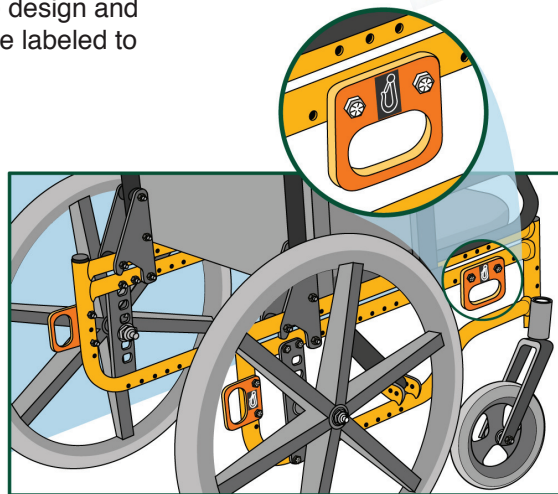

The Wheelchair Tiedown and Occupant Restraint System (WTORS)

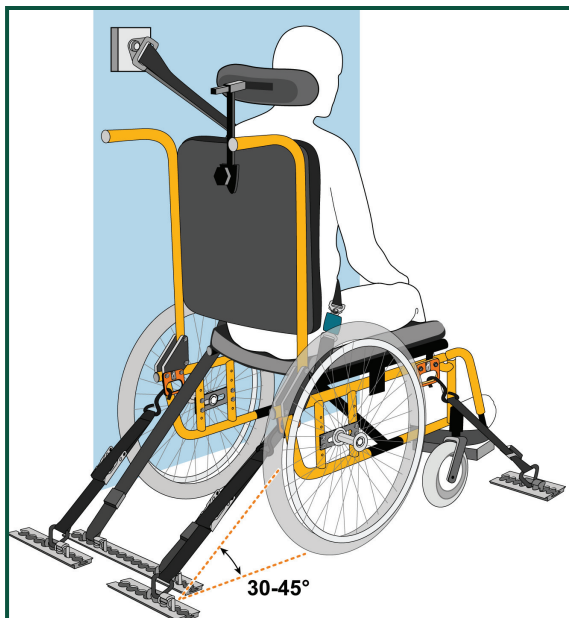

▼ It is important to use a complete WTORS to secure the wheelchair and provide the wheelchair occupant with a properly designed and tested lap/shoulder belt system.

▼ Always use a WTORS that has been crash tested and labeled as complying with **ANSI/RESNA WC18 or SAE J2249**, a voluntary standard developed by safety and rehabilitation experts. The most common type of wheelchair tiedown uses four straps to secure the wheelchair to the vehicle. Although it requires someone other than the wheelchair rider to secure and release the wheelchair, this tiedown can secure a wide range of WC19 and non-WC19 wheelchairs.

▼ To protect the rider during a crash or sudden braking, and to minimize the likelihood of injury caused by contact with the vehicle, a seatbelt system with both lap and shoulder belts must be used.

2

SECURE THE WHEELCHAIR

Four-Point Tiedowns

- ▼ Always position the wheelchair and rider facing forward in the vehicle.
- ▼ When securing a WC19 wheelchair, attach the four tiedown straps to the securement points provided on the wheelchair. Tighten the straps to remove all slack.

▼ If you do not have a WC19 wheelchair, it is best to attach the tiedown straps to welded junctions of the wheelchair frame or to other structural areas where the frame is fastened together with hardened steel bolts — indicated by six raised lines or bumps on the bolt head.

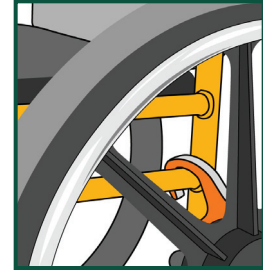

▼ **Do not attach tiedowns to adjustable, moving, or removable parts of the wheelchair such as armrests, footrests, and wheels.**

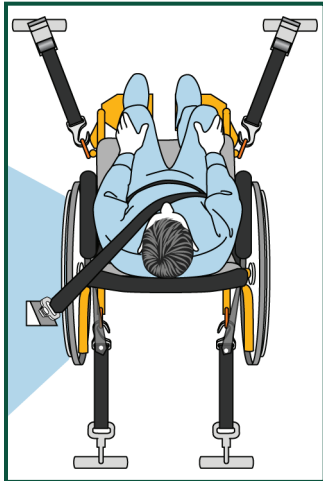

▼ When securing non-WC19 wheelchairs, choose structural securement points as close to the seat surface as possible to provide greater wheelchair stability during travel. It is best if the rear securement points are high enough to result in angles of the rear tiedown straps between 30 and 45 degrees to the horizontal.

▼ If you have a non-WC19 wheelchair with a tilt seat, make sure to attach both the front and rear straps to either the seat frame or to the base frame. Mixing wheelchair securement points between the seat and base can result in the tiedown straps becoming slack if the angle of the seat changes during a crash.

▼ It is best if floor anchor points for rear tiedown straps are located directly behind the rear securement points on the wheelchair. If possible, the front tiedown straps should anchor to the floor at points that are spaced wider than the wheelchair to increase lateral stability during travel.

Other Methods of Wheelchair Securement

▼ In addition to securing wheelchairs using a four-point tiedown, wheelchairs can also be secured using a docking tiedown device. This method is primarily used in private vehicles since it requires the addition of adaptor hardware to the wheelchair frame that will engage with the docking tiedown device in the vehicle. Docking securement devices allow the wheelchair rider to secure and release the wheelchair without assistance.

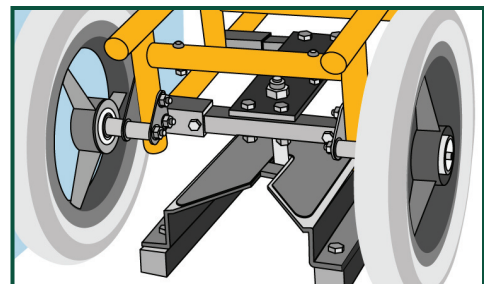

▼ If you plan to secure your wheelchair with a docking tiedown device, you should check with the WTORS or wheelchair manufacturer to ensure that your wheelchair model has been successfully crash tested with their system.

▼ Clamp-type securement devices are not recommended since they do not provide effective wheelchair securement in frontal crash testing.

3

PROTECT THE WHEELCHAIR RIDER

▼ In addition to securing the wheelchair, it is very important to provide effective restraint for the wheelchair user with a crash-tested lap and shoulder belt or with a child restraint harness. Postural support belts attached to the wheelchair are **not** strong enough to withstand crash forces and are usually not positioned correctly to restrain the occupant safely in a crash.

▼ The lap belt should be placed low across the front of the pelvis near the upper thighs, not high over the abdomen. When possible, the lap belt should be angled between 45 and 75 degrees to the horizontal when viewed from the side. Some wheelchair features, like armrests, can interfere with good belt fit. To avoid placing the lap belt over the armrest and to keep the lap belt low on the pelvis, it may be necessary to insert the belt between the armrest and the seatback, or through openings between the backrest and seat.

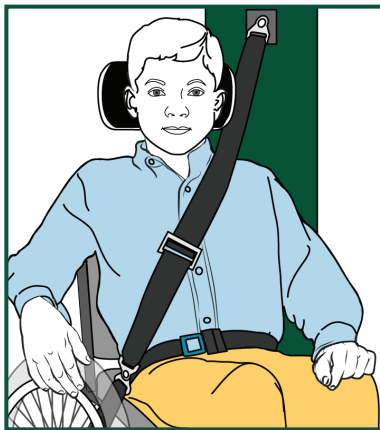
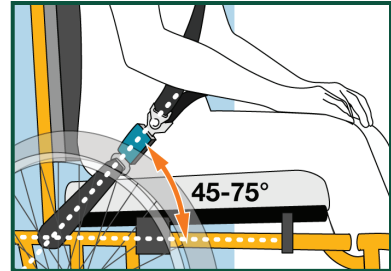

▼ A diagonal shoulder belt should cross the middle of the shoulder and the center of the chest, and should connect to the lap belt near the hip of the wheelchair rider. The upper shoulder-belt anchor point or D-ring guide should be anchored above and behind the top of the occupant's shoulder, so that the belt is in good contact with the shoulder and chest while traveling.

▼ Newer WC19 wheelchairs offer the option of a crash-tested lap belt that is anchored to the wheelchair frame. If the wheelchair has an onboard crash-tested lapbelt, complete the belt system by attaching the lower end of a shoulder belt to the lap belt. Crash-tested wheelchair-anchored lap belts will be labeled to indicate that they comply with WC19.

Other Important Points

- Read and follow all manufacturers' instructions.
- It is best to ride with the wheelchair backrest positioned at an angle of 30 degrees or less to the vertical. If a greater recline angle is needed, the shoulder belt anchor point should be moved rearward along the vehicle sidewall so the belt maintains contact with the rider's shoulder and chest.
- Maximize the clear space around the rider to reduce the possibility of contact with vehicle components and other passengers in a crash. Cover rigid vehicle components that are close to the rider with dense padding.
- Check wheelchair and WTORS equipment regularly and replace worn components. If involved in a vehicle crash, check with the manufacturer to determine if the equipment needs to be replaced. Keep WTORS anchorage track free of debris.
- If possible, remove hard trays and secure them in the vehicle to reduce the chance of rider injury from contact with the tray. Consider the use of foam trays instead of rigid trays during transit. If it is not possible to remove a hard tray, place dense padding between the rider and the edge of the tray and make sure that the tray is securely attached to the wheelchair so it will not break loose and cause injury to other occupants in a crash.
- A properly positioned headrest may help protect the neck in a rear impact.
- If it is necessary to use a head and neck support during travel, choose a soft, light, neck collar because stiff collars and head straps are more likely to cause neck injury in a crash. The soft collar should not be attached to the seating system.
- Secure medical and other equipment to the wheelchair or vehicle to prevent it from breaking loose and causing injuries in a crash.
- Seating systems can be crash tested to ANSI/RESNA WC20 and then used with a WC19-compliant frame to create a crashworthy wheelchair.

RESOURCES

Organizations

Rehabilitation Engineering Research Center on
Wheelchair Transportation Safety
www.ercwts.org

University of Michigan Transportation Research
Institute
www.umtri.umich.edu

University of Pittsburgh
www.wheelchairnet.org

RESNA Rehabilitation Engineering and Assistive
Technology Society of North America
www.resna.org

Wheelchair and Seating Manufacturers

(Ask for Products that have been Successfully Tested to WC19 and/or WC20)

Bergeron Health Care
www.specialtomato.com; 866-529-8407
Colours N Motion
www.colourswheelchair.com; 800-892-8998

Convoid
www.convoid.com; 888-266-8243

Freedom Designs
www.freedomdesigns.com; 800-331-8551

Gillette Children's Specialty Healthcare
www.gillettechildrens.org; 800-719-4040

Gunnell
www.gunnell-inc.com; 800-551-0055

Hoveround
www.hoveround.com; 800-542-7236

Innovative Products
www.mobility4kids.com; 800-950-5185

Invacare
www.invacare.com; 800-333-6900

Kids Up
www.kidsupco.com; 877-454-3787

Ki Mobility
www.kimobility.com; 800-981-1540

Metalcraft Industries
www.metalcraft-industries.com; 888-399-3232

Motion Concepts
www.motionconcepts.com; 888-433-6818

Mulholland Positioning Systems
www.mulhollandinc.com; 800-543-4769

Otto Bock
www.ottobock.com; 800-328-4058

Performance Health Products
www.v-trak.com; 866-632-1755

Permobil
www.permobil.com; 800-736-0925

Pride Mobility
www.pridemobility.com; 800-800-8586

Product Design Group
www.pdgmobility.com; 888-858-4422

Sammons Preston
www.sammonspreston.com; 800-323-5547

Stealth Products
www.stealthproducts.com; 800-965-9229

Sunrise Medical
www.sunrisemedicalonline.com; 800-333-4000

Tilite
www.tilite.com; 800-545-2266

Varalite
www.varalite.com; 800-827-4548

Wheelchair Tiedown and Occupant Restraint Manufacturers (Ask for Products that Comply with WC18 or SAE J2249)

EZ-Lock
www.ezlock.net; 225-214-4620

New Haven
www.safehaven-usa.com; 800-421-8700

Orthosafe
www.orthosafe.com; 609-587-9444

Q'Straint
www.qstraint.com; 800-987-9987

SureLok
www.sure-lok.com; 866-787-3565

GLOSSARY OF TERMS

Anchor point: The location on a vehicle, wheelchair, or wheelchair tiedown where a belt-restraint or wheelchair-tiedown anchorage is attached.

ANSI/RESNA WC18 (officially SECTION 18 RESNA WC-4:2010): A voluntary standard that specifies design and performance requirements for WTORS. NOTE: ISO 10542 is an international standard that is comparable with WC18 and SAE J2249.

ANSI/RESNA WC19 (officially SECTION 19 RESNA WC-4:2010): A voluntary standard for wheelchairs designed for use as a seat when traveling in a motor vehicle. NOTE: ISO 7176-19 is an international wheelchair standard that is comparable with WC19.

ANSI/RESNA WC20 (officially SECTION 20 RESNA WC-4:2010): A voluntary standard for wheelchair seating systems designed or used as part of a wheelchair when traveling in a motor vehicle. NOTE: ISO 16840-4 is an international wheelchair standard that is comparable with WC20.

SAE Recommended Practice J2249: A Society of Automotive Engineers Recommended Practice that specifies design and performance requirements for WTORS. NOTE: WC18 is an enhanced version of this standard and ISO 10542 is a similar international standard.

Belt: A length of energy-absorbing webbing material used in occupant restraint systems.

Docking tiedown: A method for securing wheelchairs where portions of the wheelchair frame, or add-on components fastened to the wheelchair frame, engage with a securement device anchored to the vehicle.

Four-point strap-type tiedown: A method for securing a wheelchair where four straps are attached to the wheelchair at four separate securement points and attached to the vehicle at four separate anchor points.

Occupant restraint: A system or device designed to restrain a motor vehicle occupant in a crash by keeping the occupant in the vehicle seat and minimizing contact with the vehicle interior, other occupants, or objects outside the vehicle.

Postural support: A padded component and/or belt used to help maintain a person in a desired position during normal wheelchair use. In general postural supports are **not** designed to provide effective occupant restraint in a motor vehicle crash.

Securement points: Specific structural points on the wheelchair base or seat frame that are designed for attachment of wheelchair tiedowns.

Strap: A length of webbing material used in wheelchair tiedown systems.

WC19 wheelchair: A crash-tested wheelchair with four clearly identified securement points that meets the design and performance requirements of ANSI/RESNA WC19 and is sometimes called a transit wheelchair.

WC20 seating system: A crash-tested seating system and its attachment hardware that meets the design and performance requirements of ANSI/RESNA WC20 and is used with a WC19 compliant frame to create a crashworthy wheelchair.

Wheelchair tiedown and occupant-restraint system (WTORS): A complete system for use by wheelchair-seated occupants comprised of a system or device for securing the wheelchair and a belt-type restraint system for limiting occupant movement in a motor vehicle crash.

Rehabilitation Engineering Research Center on Wheelchair Transportation Safety

University of Michigan Health System

University of Michigan Transportation Research Institute

Initially funded through a grant from the FRIENDS of the University of Michigan Hospitals

2010



Lap-Shoulder Belt Basics

“Buckle, Check, Tight — Your Seat Belt Is Right!”

Common Seat Belt Parts

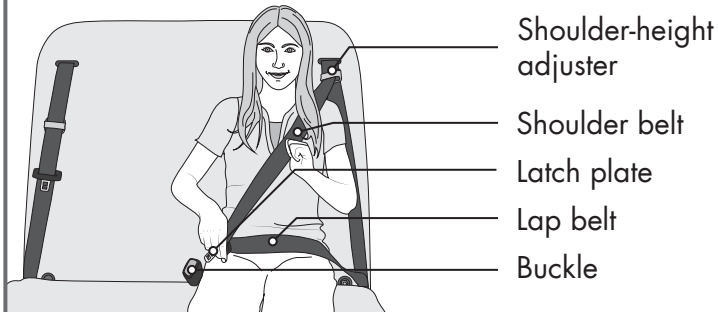

I have read and discussed these important safety instructions with my child.

Parent/Guardian Signature _____ Date _____

Child _____ Date _____

Instructor _____ Date _____

BUCKLE

CHECK

TIGHT

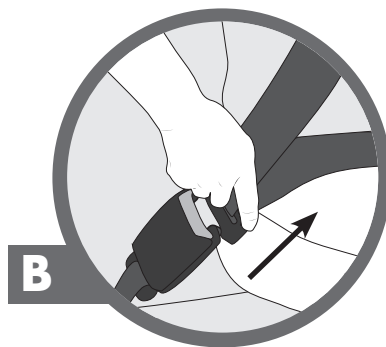
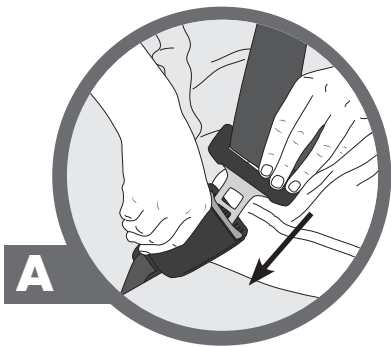

A BUCKLE the latch plate into the matching buckle after pulling out the shoulder belt webbing from the seatback. LISTEN for the CLICK sound when the latch plate is fastened!

Be sure to:

- Sit flat against the seatback.
- Place the lap-shoulder belt over shoulder and around upper body. Do not let the belt get twisted.

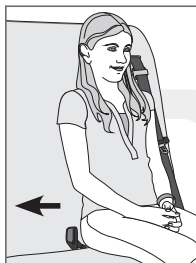

B CHECK that the buckle connection is secure by tugging firmly on the seat belt latch plate.

Be sure to:

- CHECK while sitting against the seatback.
- Remove any twists in the seat belt when you CHECK.

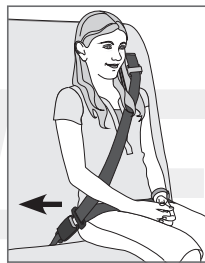

C TIGHTEN the lap portion by pulling upward on the shoulder belt. Be sure that the shoulder belt is snug across the chest and crosses the center of the shoulder.

Be sure to:

- Properly position lap portion below the waist, not over the stomach.
- Position the shoulder-height adjuster at or just above the shoulder. The belt should not cross the face or neck.



UNBUCKLING

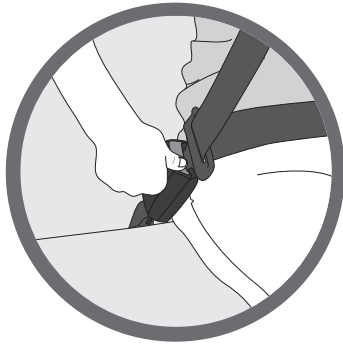

1. Push the red button on the buckle and remove the latch plate from the buckle.
2. Allow the shoulder belt to retract into the upper seatback.



3. As a courtesy to the next passenger, move the shoulder-height adjuster up to its highest position.

IMPROPER LAP-SHOULDER BELT USE



NEVER sit in front of the buckled lap-shoulder belt.

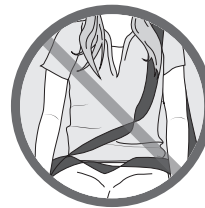

NEVER allow the webbing to be twisted. It should lay flat against your body.



NEVER place the shoulder belt behind your back and wear only the lap belt.



NEVER insert the latch plate of your shoulder belt into the buckle for the seat beside you. Be sure to use your own buckle.

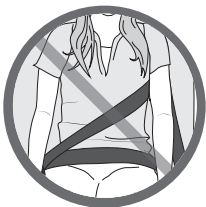

NEVER place the shoulder belt under your arm.



NEVER wear your backpack when you are seated in the bus. Place it on the floor in front of your feet.

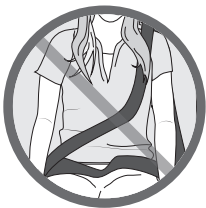

NEVER wear the shoulder belt or lap belt loosely.



NEVER sit on the front or side edge of your seat.

INSTALLATION SIGNOFF SHEET

Student Name: _____

Date: _____ Conf/Event Name: _____

_____ **Rear-facing only seat without a base**

_____ **Rear-facing only seat with a base**

_____ **LATCH Rear-facing only seat with a base**

_____ **Combination seat - lap belt**

_____ **Convertible seat rear-facing**

_____ **Convertible seat forward-facing**

_____ **LATCH Convertible seat forward-facing**

_____ **Child in Integrated**

_____ **Safety vest**

_____ **Star Seat**

_____ **Pro Tech II or III**

_____ **Portable Child Restraint**

_____ **School Bus Specific Lap Belt Add-On CSRS**

E-Z-ON®
Adjustable Vest
Model #103Z
for School Buses

Zippers must always be in the back

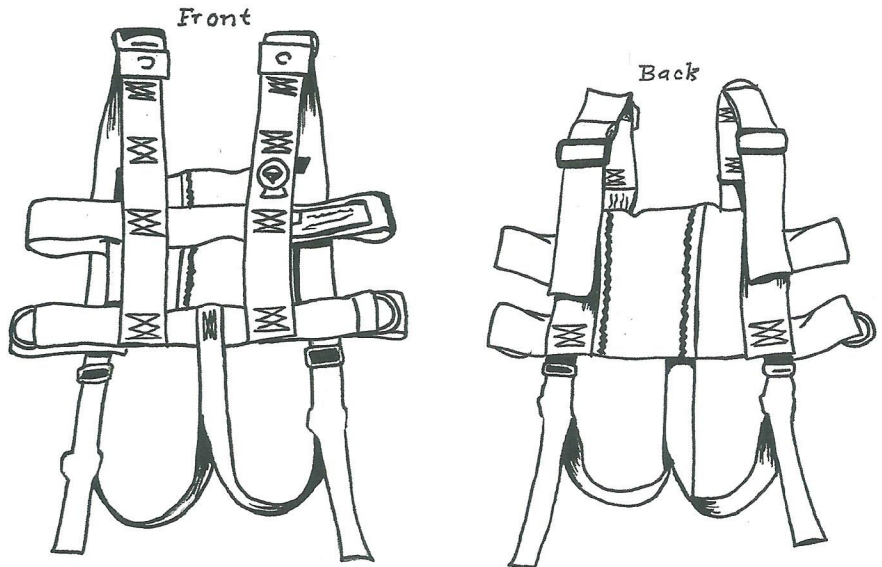

- 103Z Vests XXS-M come with crotch straps meeting NHTSA guidelines
- Meets FMVSS213 requirements
- **Use** for a passenger 20-168 lbs. only

Passengers seated behind occupants with the Seat Mount must be restrained with a seat belt or other restraint, or the seat be unoccupied.

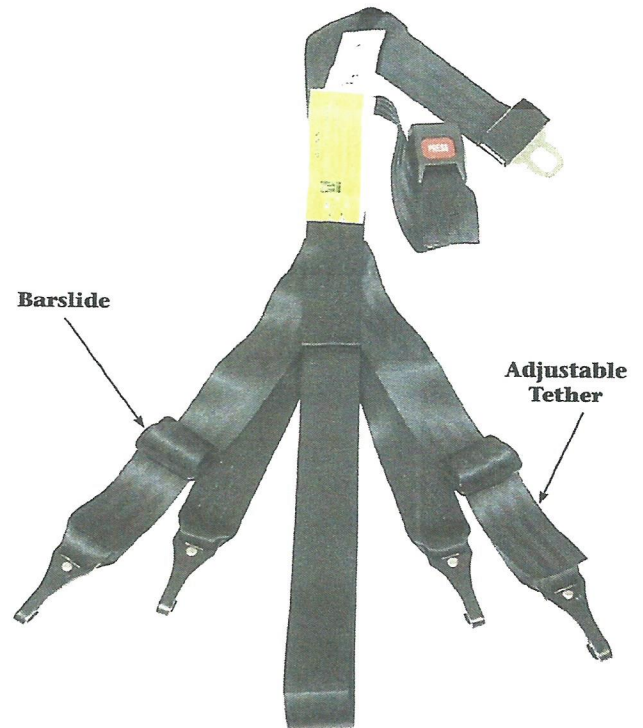

How to Register This Child Restraint

Child restraints could be recalled for safety reasons.

You must register this restraint in order to be notified of recall.

Fill out the REGISTRATION CARD enclosed with your E-Z-On® Vest, send your name address and the restraint model number and manufacturing date to the address below or log on to our website www.ezonpro.com and full out your product information via our registration page.

For recall information, call the U.S. Government Auto Safety Hotline at 1-800-424-9393. In the Washington D.C. area call 202-366-0123.



E-Z-ON®

Products, Inc. of Florida

605 Commerce Way West • Jupiter, Florida 33458

800.323.6598 • 561.747.6920 • Fax 561.747.8779

www.ezonpro.com

103Z with Seat Mount (Cam Wrap) Model #100S Installation for School Buses

INSTALLING THE SEAT MOUNT

Bus seats must have access between the bus seat cushion and seat back.

1. **Unlock** bus seat and lift up.
2. **Hang** the adjustable hook ends from the top of the bus seat.
3. **Wrap** the mount strap around the bus seat;
 - a. **lower** the push button strap over the back of the bus seat,
 - b. **place** the face of the push button against the bus seat back,
 - c. **wrap** the connector strap down and around seat frame to connect to the push button.
4. **Snap** the push button and connector together.
5. **Pull** webbing snug to create wrinkle and crease on bus seat top.
6. **Mount** strap must be snug without slack in the webbing.
7. **Allow** fixed hook ends to extend only 2" on bus seat
8. **Close** and **lock** bus seat.

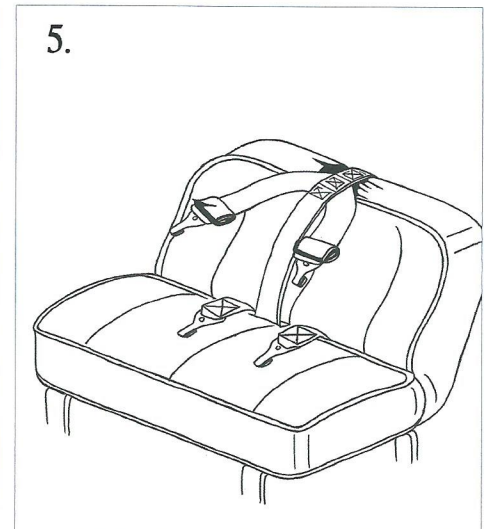
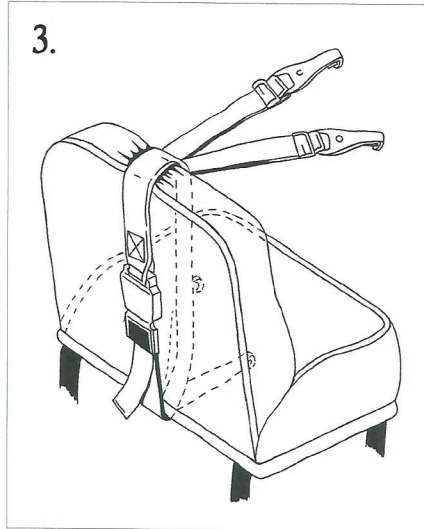

SECURING THE PASSENGER

Be sure the passenger:

- **has a properly fitted vest**
- **has all closures secure**
- **sits upright with buttocks against the bus seat back**

1. **Attach** non-adjustable E-Z-ON hook ends to the d-rings on the vest hip straps.
2. **Attach** adjustable hook ends to the shoulders of the vest tether slots on the adjusters (103Z)



3. **Correct** the length on the adjustable hook ends to secure the passenger. This allows the passenger to sit upright without leaning forward.
 - a. **Hold** the loose end, move the bar slide and hook to adjust to the correct length.
 - b. **Thread** the loose end back through the bar slide as shown.
 - c. **Push** the bar slide down against the metal hook
 - d. **Thread** the loose end back through the bar slide and pull the webbing snug.

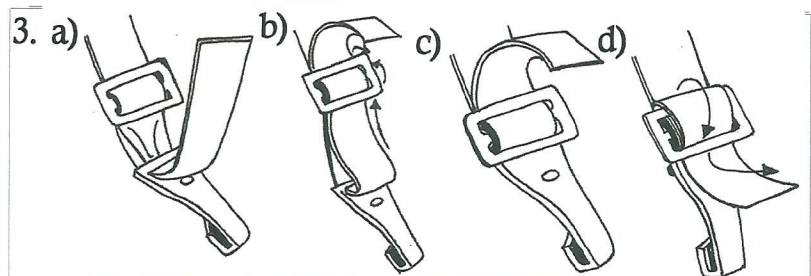

4. To adjust crotch strap, pull down
5. Be sure you follow all instructions on the vest and seat mount to secure the passenger

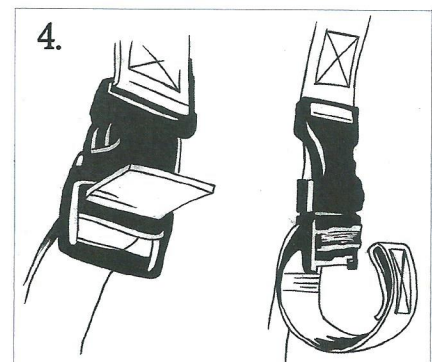



WARNING! DEATH or SERIOUS INJURY can occur if manufacturer's instructions are not followed correctly.

E-Z-ON®
Model #1086
CamHarness™
for School Buses
Owners Manual

- **Use** on a school bus seat only
- Meets FMVSS213
- **Use** for a passenger weighing 30-80 lbs.
- You **must** use this CamHarness™ restraint with a school bus lap belt.
- **Replace** after a crash or 5 years from the date of manufacture.
- Crotch straps are **not** needed when used with a Booster.
- **Be sure** to register this restraint to be notified of a safety recall.
- **Passengers seated behind occupants in CamHarness™ must be restrained with a seatbelt or other restraint, or the seat be unoccupied**



E-Z-ON®
Products, Inc. of Florida

605 Commerce Way West • Jupiter, FL 33458

800-323-6598/561-747-6920 • Fax 561-747-8779 • www.ezonpro.com

© 2005 E-Z-ON®

E-Z-ON® Model #1086 CamHarness™ for School Buses Owners Manual

Attaching the CamHarness™
to the school bus seat for
passengers weighing 30-80
pounds.

Step A

Bus seats must have entry
between seat bottom and
seat back to install.

- 1. Unlock** bus seat and lift up.
- 2. Place** the Y-Center on the seat top
Rest shoulder straps on the front of the bus seat.
- 3. Wrap** the cam strap around the bus seat:
 - a. the female push button must face the back of the seat, below passenger knee level.
 - b. the male buckle strap wraps down around seat frame to meet the female push button.
- 4. Snap** the push button and buckle together and pull webbing snug to create wrinkle and crease on bus seat top.
- 5. Allow** crotch straps to stretch out and rest on bus seat. **Close** and **lock** bus seat.

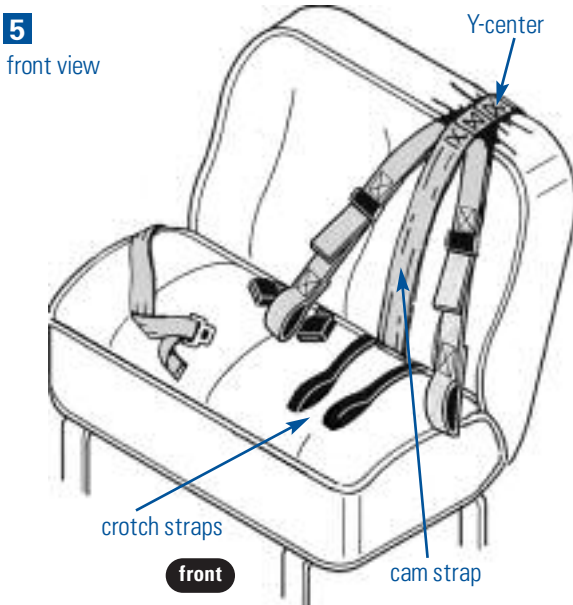
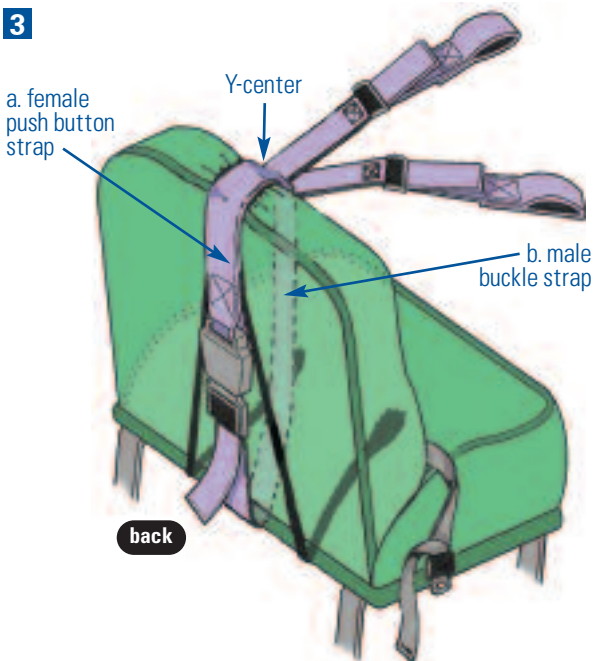

Step B

Securing the Passenger:

Be sure the passenger sits upright with buttocks against the seat back.

1. **Place** harness straps over each shoulder.
2. **Locate** the crotch straps in the center of the passenger's legs.
3. **1st** thread lap belt through the 1st crotch loop, **2nd** through the 1st harness loop, **3rd** through the last harness loop and **4th** through the last crotch loop.
4. **Buckle** lap belt low across the lap. **Reduce** lap belt slack.
5. If using a booster no crotch straps are necessary according to NHTSA regulations. **Thread** lap belt through both harness loops and **keep** lap belt under booster arms. **Reduce** lap belt slack.

Step C

Adjusting the Harness Straps on the passenger:

1. **To shorten harness straps:** **Tilt** the adjuster up on each harness. **Pull** loose ends of webbing to shorten.
2. **To lengthen harness straps:** **Tilt** the adjuster up on each harness. **Pull** harness loop ends downward, to lengthen. Lap belt is threaded through loop ends.
3. **Keep** both adjusters at the same height on the passenger.

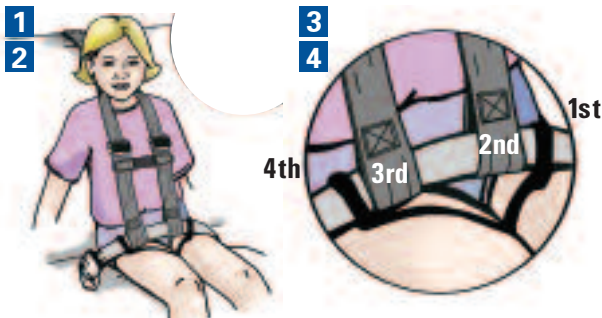

! WARNING! Failure to thread the crotch straps like this could cause injury.

Step C

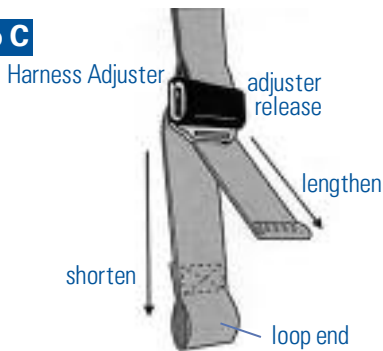

! WARNING! DO NOT shorten harness length to much. This could pull lap belt up, over stomach and cause injury. Harness should fit securely without slack. Some seat belts have long fixed (female) ends. NHTSA recommends 7.5 inch fixed belt ends for best fit. **A booster helps keep lap belt low when seat belt fixed ends are too long.** A-105

Step D

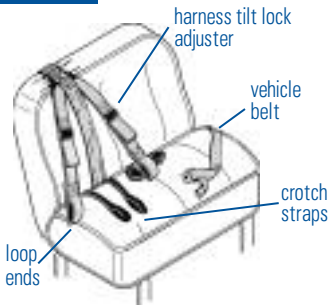

Step D

Adjusting the crotch straps

1. Be sure crotch straps are snug but **not** too tight.
2. Crotch straps may not be long enough due to different sizes of bus seats and passengers.
 - a. **rotate** cam strap backward to give length to crotch straps.
 - b. **DO NOT rotate cam strap more than 6 inches from the Y-Center placement on the top of the bus seat.**
 - c. **Order** crotch strap extenders from E-Z-ON® if the above steps do not correct the problem.

Step E

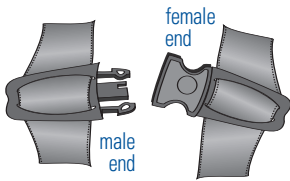

Step E

Adjusting the chest clip

- Squeeze** male end to fit in the female end to secure.
- a. **squeeze** the male end to release.
 - b. **keep** the clip below the harness adjusters at arm-pit level.

How to Register This Child Restraint

Child restraints could be recalled for safety reasons.

You **must register** this restraint in order to be notified of a recall.

Fill out the REGISTRATION CARD enclosed with your E-Z-ON® Harness, **send** your name address and the restraint model number and manufacturing date to the address below or **log on** to our website www.ezonpro.com and **fill out** your product information via our registration page.

For recall information, **call** the U.S. Government Auto Safety Hotline at 1(800) 424-9393. In the Washington D.C. area call (202) 366-0123.



E-Z-ON®

Products, Inc. of Florida

605 Commerce Way West • Jupiter, FL 33458

800-323-6598/561-747-6920 • Fax 561-747-8779 • www.ezonpro.com

© 2005 E-Z-ON®

A-106

! WARNING! DEATH or SERIOUS INJURY can occur if manufacturer's instructions are not followed correctly.

E-Z-ON® Model #543 KidCam™ *for School Buses*

- Use on a school bus seat only
- Meets FMVSS213.
- Use for a passenger weighing 30-80 lbs.
- You **must** use this KidCam™ restraint with a school bus lap belt.
- **Replace** after a crash or 5 years from the date of manufacture.
- Crotch straps are **not** needed when used with a booster.
- **Be sure** to register this restraint to be notified of a safety recall.
- **Passengers seated behind occupants in KidCam™ must be restrained with a seatbelt or other restraint, or the seat be unoccupied.**



E-Z-ON®
Products, Inc. of Florida

605 Commerce Way West • Jupiter, FL 33458

800-323-6598/561-747-6920 • Fax 561-747-8779 • www.ezonpro.com

© 2005 E-Z-ON®

E-Z-ON® Model #543 KidCam™ for School Buses Installation Guide for School Buses

Bus seats must have seatbelts and access between the seat cushion and seat back to install.

Step 1

Attaching the KidCam™ to the school bus seat for passengers weighing 30-80 lbs.

1. **Unlock** the bus seat and lift up.
2. **Place** the Y-bridge on the seat top ;
 - a. **rest** black shoulder straps on the front of the bus seat,
 - b. **allow** crotch straps to pass through the seat opening to rest on the bus seat. **Close and lock** the bus seat.
3. **Wrap** the gray cam strap around the bus seat:
 - a. **lower** the o-bracket over the back of the bus seat,
 - b. **pass** the snap hook through the front seat opening.
4. **Attach** the snap hook onto the o-bracket.
5. **Secure** the gray cam strap:
 - a. **press** the spring lock,
 - b. **pull** gray webbing end snug,
 - c. **create** a crease on top of the bus seat.

2
front of
bus seat

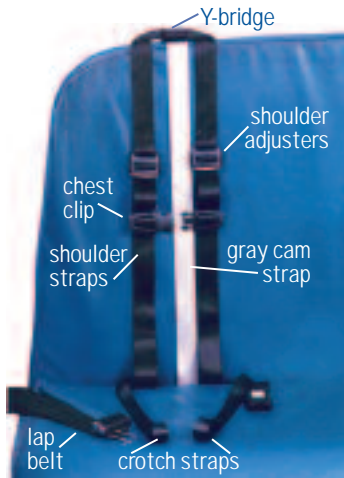

3



4

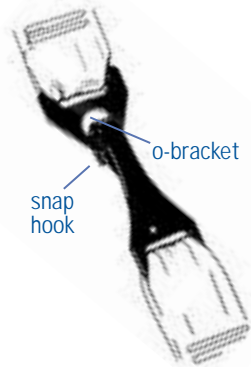

5

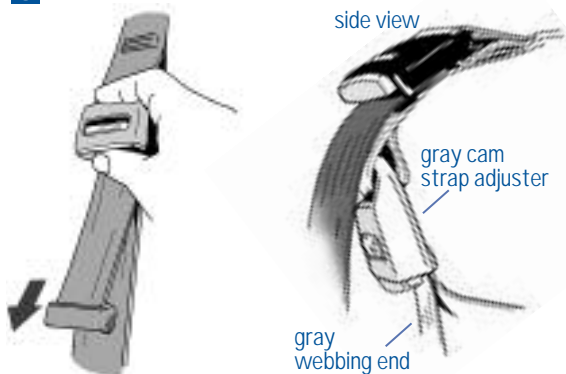

Step 2

Securing the Passenger:

Be sure the passenger sits upright with buttocks against the seat back.

1. Place harness straps over each shoulder.
2. Locate the crotch straps in the center of the passenger's legs.
3. 1st thread lap belt through the 1st crotch loop, 2nd through the 1st harness loop, 3rd through the last harness loop and 4th through the last crotch loop.
4. Buckle lap belt low across the lap. Reduce lap belt slack.
5. If using a booster no crotch straps are necessary according to NHTSA regulations. Thread lap belt through both harness loops and keep lap belt under booster arms. Reduce lap belt slack.

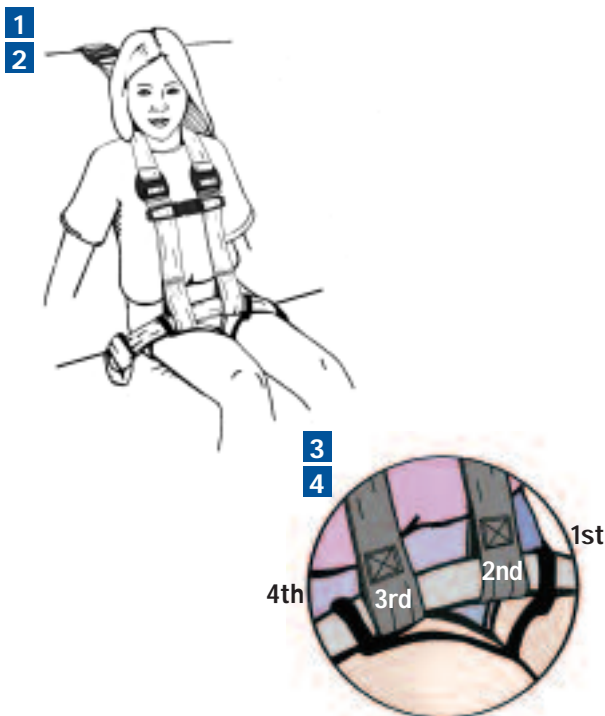

! WARNING! Failure to thread the crotch straps like this could cause injury.

Step 3

Adjusting the Harness Straps on the passenger:

1. To shorten harness straps: Press the spring-locks on each harness adjuster. Pull loose ends of webbing to shorten.
2. To lengthen harness straps: Press the spring-locks on each harness adjuster. Pull harness loop ends (lap belt is threaded through these) downward, to lengthen.
3. Keep both adjusters at the same height on the passenger.

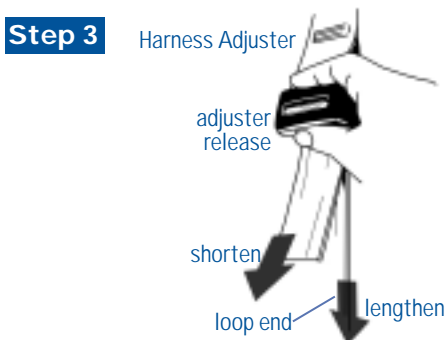

! WARNING! DO NOT shorten harness length to much. This could pull lap belt up, over stomach and cause injury. Harness should fit securely without slack. Some seat belts have long fixed (female)ends. NHTSA recommends 7.5 inch fixed belt ends for best fit. A booster helps keep lap belt low when seat belt fixed ends are too long.

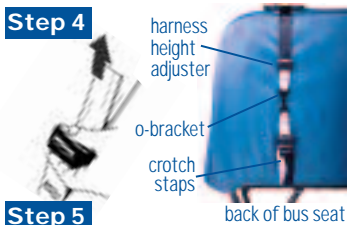
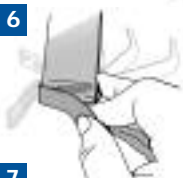
**Step 5****Step 6****Step 7****Step 4**

Adjusting the Harness Height Adjuster on passenger.
Keep both harness adjusters even on passenger.

1. **Adjust** harness height by sliding **Y-bridge** on gray cam strap.
2. **Harness height adjuster** is attached to gray cam strap above the o-bracket.
3. **Press** spring-lock on **height adjuster**:
 - a. **pull** black webbing end to shorten harness height,
 - b. **pull** harness to lengthen harness height.

Step 5

Adjusting the crotch straps

1. **Adjust** crotch straps snug but not too tight.
2. **Press** spring-lock on crotch strap adjuster:
 - a. **pull** black webbing end to shorten straps,
 - b. **pull** harness to lengthen straps.

Step 6

Adjusting velcro-tab

1. **Roll-up** webbing ends on the **height adjuster**, the **crotch strap adjuster** and the **cam adjuster**.
2. **Secure** the velcro-tab.

Step 7

Adjusting the chest clip

1. **Squeeze** male end to fit in the female end to secure.
 - a. **Squeeze** the male end to release.
 - b. **Keep** the clip below the harness adjusters at arm-pit level.

How to Register This Child Restraint

Child restraints could be recalled for safety reasons.

You **must register** this restraint in order to be notified of a recall.

Fill out the REGISTRATION CARD enclosed with your E-Z-ON® Harness, send your name address and the restraint model number and manufacturing date to the address below or **log on** to our website www.ezonpro.com and **fill out** your product information via our registration page.

For recall information, **call** the U.S. Government Auto Safety Hotline at 1 (800) 424-9393. In the Washington D.C. area call (202) 366-0123.



E-Z-ON®
Products, Inc. of Florida

605 Commerce Way West • Jupiter, FL 33458

800-323-6598/561-747-6920 • Fax 561-747-8779 • www.ezonpro.com

© 2005 E-Z-ON®



Our Over the Shoulder Securement

is designed and tested to meet FMVSS-213 standard, along with FMVSS-302 flammability requirements. The Securement must be used with an existing lap belt on a 210 seat frame in order to meet the FMVSS-213 Standard.

Sizes:

- Adult Hi Back
- Adult Low Back
- Child Hi Back
- Child Low Back

The Over the Shoulder Securement is an added way to give extra upper body support when being transported in a school bus.

Assembly Instructions

1. Unbuckle existing seat belt, lift bench seat and insert the tongue part of the buckle end between seat cushion and backrest, leaving the 1 1/2" webbing (crotch strap) lay on the seat cushion.
2. Lay the two shoulder straps over the top on the seat back.
3. Buckle the unit on the backside of the seat back.
4. Place the passenger in the seat; the crotch strap should be between the legs.
5. Thread the lap belt through the first shoulder strap then through the crotch strap loop, then through the remaining shoulder strap and buckle the unit.
6. Buckle chest clip at arm pit level.
7. Pull lap belt snug around hips.
8. Tighten seat mount buckle on back of seat

Adjustable Securement Vest

1. Lift the cushion portion of the bench seat, and place the male end of the cam wrap buckle in the space between the seat cushion and seat back. Close and secure the seat cushion assembly. On some seats lifting the seat cushion is unnecessary, simply push the male end of the seat mount through the seat bite, between the cushion and back until it is visible from behind and below the seat.
2. Place the female end of the seat mount buckle over the top of the seat back and bring the male end around from the bottom. Click belt buckle together making sure that red release button is facing inward
3. Check to make sure that bottom hooks of seat mount are 1 to 3 inches out of the seat bite; then tighten the seat mount until an indentation is made in the top of the seat foam.

Attaching Vest To Seat Mount

1. With passenger sitting down secure the upper and lower D-rings of the vest to the snap hooks on the seat mount.
2. Make sure passenger is snug against the seat bottom and back. If adjustment is necessary unhook the top D-rings from the snap hooks and raise or lower the upper yoke of the seat mount using the provided adjuster, then secure D-rings.
3. Recheck to make sure that the seat mount is tight and adjust as necessary.

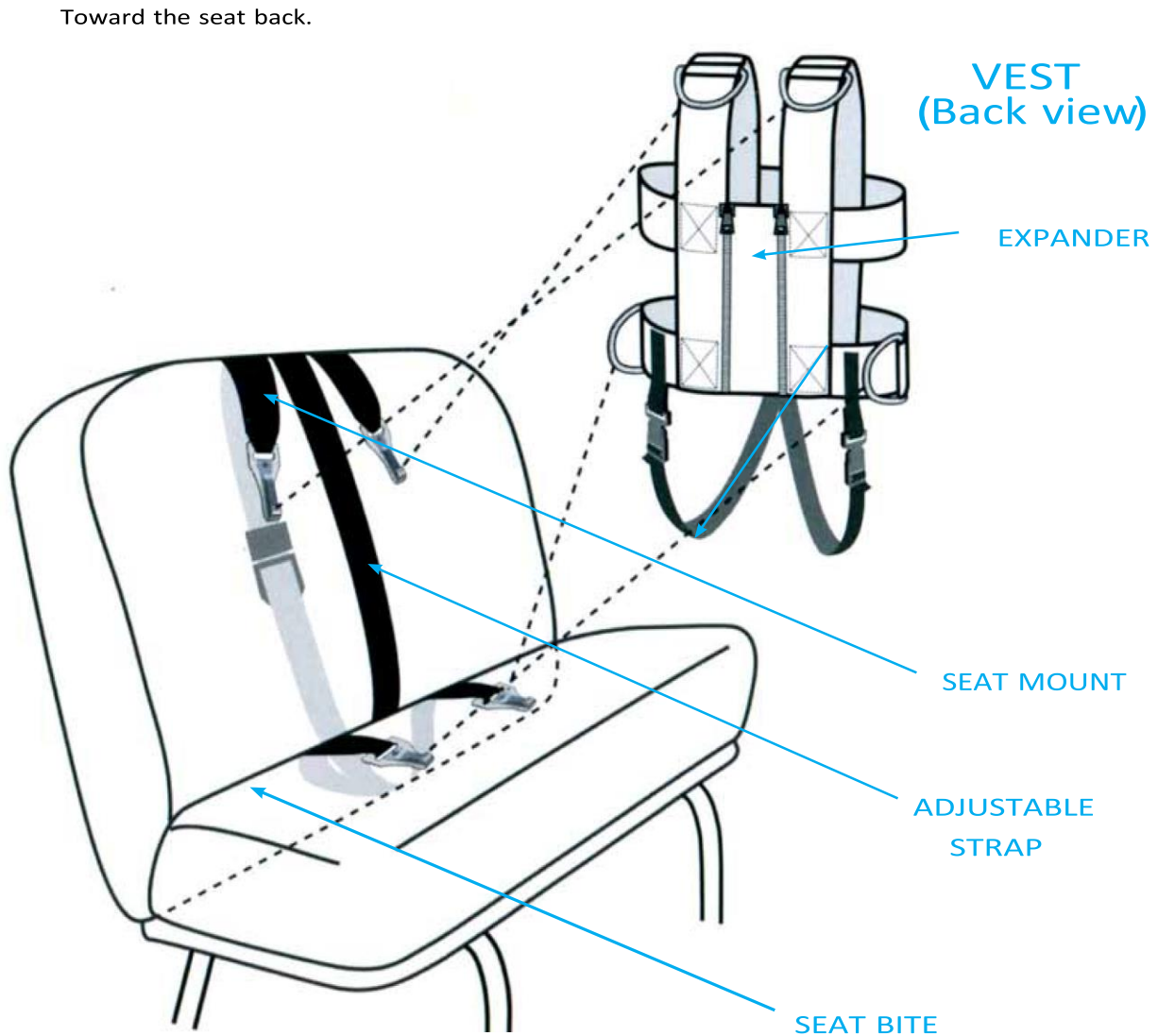

BESI Installation Instructions

Adjustable Securement Vest Insert Instructions

1. Place the vest on the passenger with zipper facing the rear.
2. Zip the vest from the rear making sure that it fits snug by selecting the correct zipper expander to zip into.
 - a. Universal Vest have an adjustable expander.
 - b. BESI Vest inserts are separate. Each insert expands 2 - 4 inches added together the maximum expansion is 6 inches.
3. The vest should fit as low on the hips as possible and should be placed under, not over heavy coats or other oversized winter garments.
4. On the Universal Vest shoulder height adjustments can be made on the vest by holding the par adjuster with one hand and pulling down to tighten, or up to loosen the webbing.
5. Buckle the crotch strap (if equipped) and adjust length by pulling up or down on the webbing so that it fits snug yet comfortably for the child.



Universal Vest with Adjustable Expander

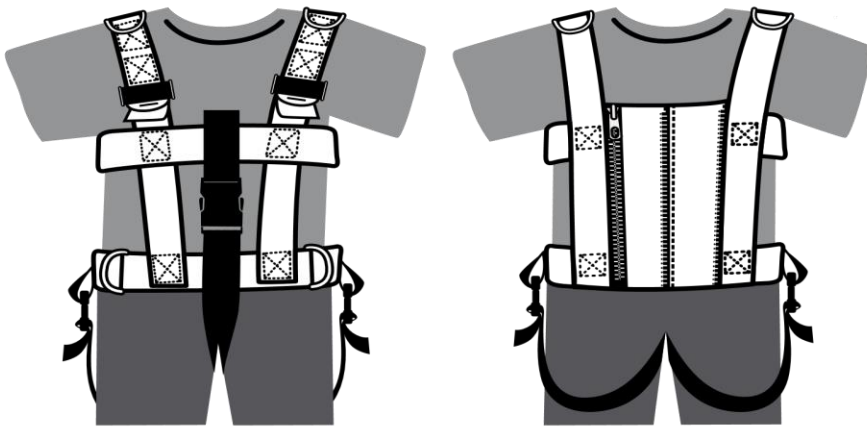

VEST (front view)

VEST (back view)

BESI Securement Vest with Separate inserts

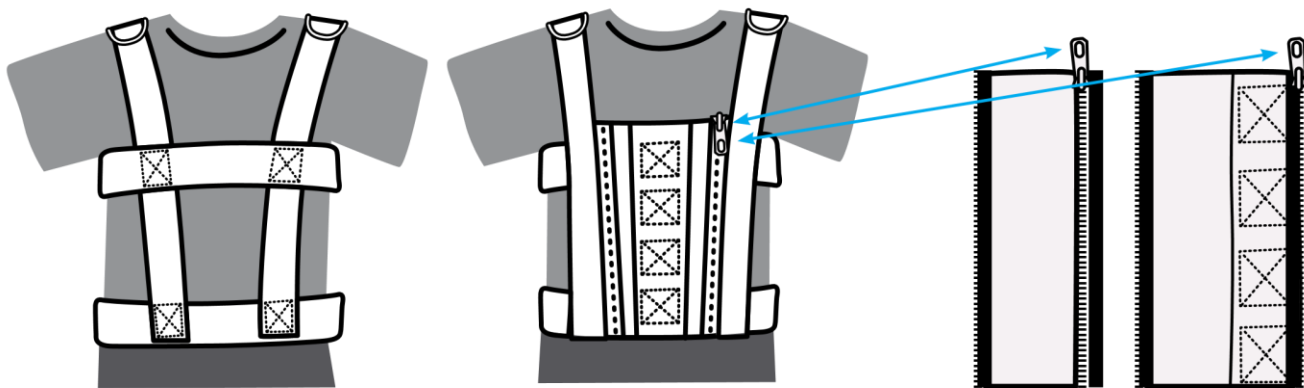

VEST (front view)

VEST (back view)

BESI Installation Instructions

Pro Tech II and Pro Tech III Assembly Instructions



1. Unlatch lift and tilt seat cushion forward



2. Unfold unit. Take the cam-wrap strap with the buckle tongue end and 1.5" strap and drop down between the back and cushion.



3. Put cushion in place and latch. Under the cushion, bring forward and connect the 1.5" strap to the front side buckle on front of seat (hold the pad on the seat).



4. Push the Pro-Tech snug against the seat back. Connect the cam-wrap on the back of the seat and adjust to a snug position.



5. Adjust torso height to be at or above shoulder height by sliding webbing out and into the correct slot for proper adjustment. Lower slot for shorter, middle slot for medium and upper slot for taller occupants.



6. When using the Pro-Tech II place child in seat. Connect the color coded straps together. Pull the adjustment straps to fit firmly across the hip and shoulder areas. You should not be able to pinch up the webbing. (Pinch Test)



7. When using the Pro-Tech III Place child in seat. Connect the left and right side straps into the center push button buckle, pull the adjustment straps to fit firmly across the hip and shoulder areas. You should not be able to pinch up the webbing. (Pinch Test)

***Warning!** Securement must only be used on school bus seats. Entire seat directly behind must be unoccupied or have secured occupants.

Recommended replacement after 5 years in service.



THE C.E. WHITE CO.

Owner's Manual Supplement

Operating Instructions for Integrated Child Safety Seat Type CR11

417 N. Kibler St., New Washington, OH 44854 | Tel. 419.492.2157 | Website: www.cewhite.com

It is important to use an approved rearward facing infant restraint for a full year to allow the neck and spine to develop enough to support the weight of the child's head in the event of a collision.

Who should use this child seat?

This integrated child seat is designed for use only by children who weigh between 20 and 85 pounds.

» **WARNING!**

Failure to follow these instructions can result in your child striking the vehicle's interior during a sudden stop or crash. Snugly adjust the belts provided with the child restraint around your child.

Refer to the picture below to become familiar with the parts of the child seat and five-point seat belts. This child restraint system conforms to U.S. Federal Motor Vehicle Safety Standard 213 and Canada Motor Vehicle Safety Standard No. 213.4

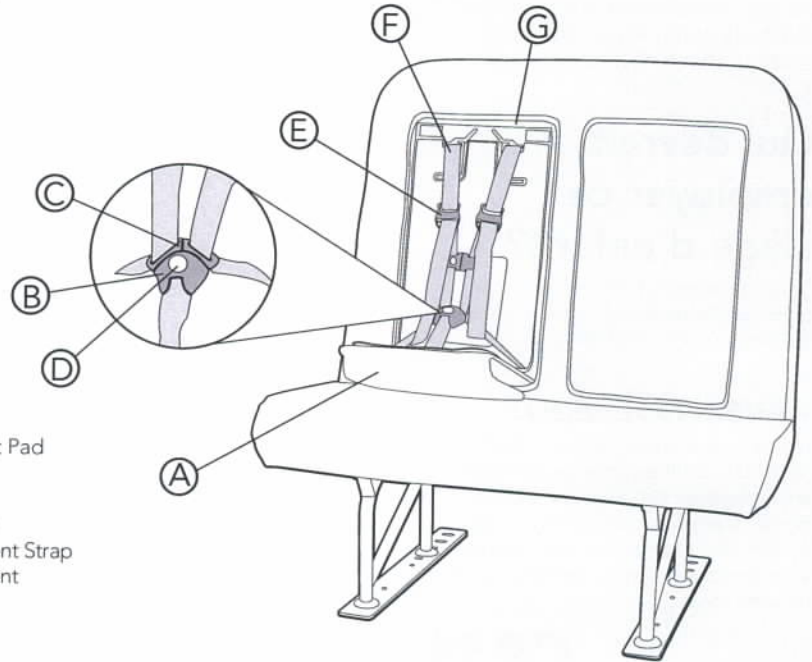

- A. Folded Down Leg Rest Pad
- B. Buckle
- C. Seat Belt Latch Plates
- D. Buckle Release Button
- E. Shoulder Belt Adjustment Strap
- F. Shoulder Belt Adjustment
- G. Removable Pad

CR11

To open the child restraint:

Grasp the upper portion (leg rest pad) and lower the child seat cushion.

To secure the child:

- 1 Before placing the child in the seat, add slack to the shoulder belts. Release the seat belts by pulling up on the shoulder belt adjustment strap located at the top of the seat, then pull on the seat belts.
- 2 Place the child into the child seat, pull the shoulder belts through the appropriate shoulder slot for the height of the child and put a shoulder belt over each shoulder. Insert both seat belt latch plates into the buckle and pull up on them to make sure they are firmly latched.
- 3 Fasten the two halves of the shoulder belt clip together and put it 2-3 inches below the child's chin. The purpose of the clip is to keep the shoulder belts positioned correctly on the shoulders.

To remove the child:

Reverse steps 1-3.

» **WARNING!**

A frayed or torn child restraint belt could rip apart in a collision and leave your child with no protection. Inspect the belt system periodically, checking for cuts, frays, or loose parts. Damaged parts must be replaced immediately. Do not disassemble or modify the system.

Child restraint belt systems must be replaced after a collision if they have been damaged (bent buckle or 5-point connector, torn webbing, etc.) Similarly, the child restraint-equipped bench or bucket seat must be replaced after a collision if it is damaged (bent or broken seat frame, etc.)

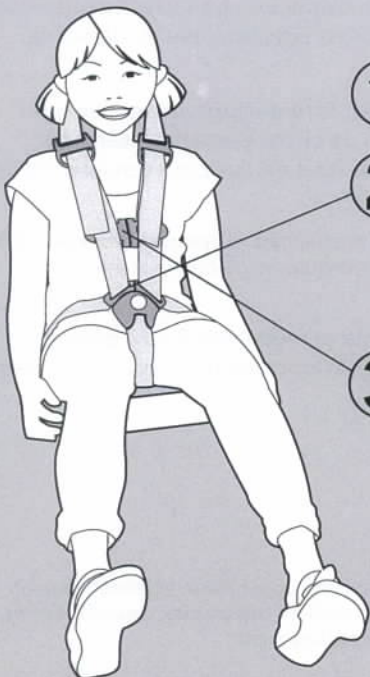



Go quickly and safely.

Convenient, innovative fold up case* opens up quickly to provide a five-point child restraint.



The C.E. White Portable Child Restraint Seat (PCR) from HSM Transportation Solutions

Designed for transporting young children, this innovative PCR provides the best of both worlds: a convenient fold up carrying and storage case when not in use, then it unfolds fast into a five-point restraint system that meets National Highway Transportation Safety Administration (NHTSA) regulations for children.

**Patent Pending*

HSM
Transportation Solutions

The C.E. White Portable Child Restraint.



C.E. WHITE

Count on these innovative features.

Accommodates children 20–90 lbs. and up to 57" height

All belts and attachment straps fold conveniently inside the self-contained carrying case*

Vertical shoulder height adjustments



Meets and exceeds FMVSS 213 and all Head Start Standards

Attaches quickly and easily to any school bus seat without requiring seat belt



Make life easier and safer: Go with the C.E. White PCR system from HSM Transportation Solutions

To install, drivers simply place the carrying case on the seat, unfasten the Velcro lip and unfold the case to create a cushioned seat. A belt wraps around the bus seat and attaches to the PCR, while the built-in five-point harness provides an adjustable restraint system for children from 20 to 90 pounds.

When not in use, the seat converts to a self-contained carrying case with an adjustable strap that creates a handle or shoulder strap which makes it easy to carry, reducing wear and tear and increasing the useful life of the system.

**Patent Pending*

HSM
Transportation Solutions



Care and Maintenance

The webbing and seat pad can be cleaned on the seat with a damp cloth using mild soap solution and lukewarm water. The pad can be removed for machine washing in cold water on gentle cycle and tumbled dry on low heat. Do not use chlorine bleach or dry clean the pad.

The seat pad is connected to the base with the use of hook and loop fasteners. To remove, pull up on the pad to remove from the base and disconnect the hook and loop fasteners on the back of the pad in two places.

If the seat pad becomes overly soiled or damaged, a replacement pad can be ordered from your original place of purchase or by calling 877-447-2305.

STAR Restraint Replacement

The STAR restraint system is considered to have a finite life and must be frequently inspected and replaced as needed. The service life of a STAR restraint is 6 years from the date of manufacture. Discontinue use of the STAR after that date. The date of manufacture can be found on the back of the lower portion of the cam wrap strap where it connects to the seat base.

The STAR and its components must be inspected frequently (per instructions below). If you have any doubts about the condition or function of the restraint, REPLACE IT, even if it is less than 6 years from the date of manufacture.

If any component or part of the STAR restraint requires replacement (with the exception of the replaceable pad), the entire system must be replaced. If the vehicle is involved in a significant accident, the entire STAR restraint must be replaced.

STAR Restraint Inspection

1. Inspect harness webbing on entire system for cuts, fraying, or extreme or unusual wear. Most common areas of belt wear include the buckle/latch area and any place where the restraint makes contact with the vehicle or seat.
Corrective action — Replace entire STAR restraint.
2. Inspect latch and buckle for proper operation by inserting the latch into the buckle. Latch must insert smoothly, and you must hear an audible click. Verify proper latching by tugging on the belt. Latch must not be worn, deformed or corroded. Buckle must not be damaged, cracked or broken.
Corrective action — Replace entire STAR restraint.

3. Inspect the seat belt height adjuster for damage. Move adjuster up and down. It must move freely and should not be damaged, cracked or broken.
Corrective action — Replace entire STAR restraint.

4. Inspect dual cam wrap system for cuts, fraying, or extreme or unusual wear.
Corrective action — Replace entire STAR restraint.

5. Inspect chest clips for damage and operation. Chest clip halves should not be damaged, cracked or broken. Clips should engage and disengage smoothly with each other. Move clip halves up and down. They must move freely.
Corrective action — Replace entire STAR restraint.

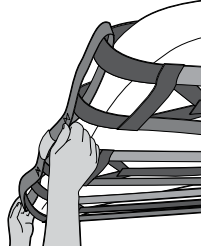

Accessory - Connector Strap

Allows the positioning of three standard STAR restraints on a 39" school bus seat.

Federal Safety Standards

The Safeguard STAR restraint is certified to applicable U.S. Federal Motor Vehicle Safety Standard FMVSS 213 and 302.

Safeguard®

STAR

Student Transportation Add-On Restraint

Instruction Manual



STAR

- 25 - 65 lbs. (11.3 - 29.5 kg)
- 57 in. (144 cm) tall or less
- over 1 year of age



STAR plus

- 25 - 90 lbs. (11.3 - 40.8 kg)
- 57 in. (144 cm) tall or less
- over 1 year of age

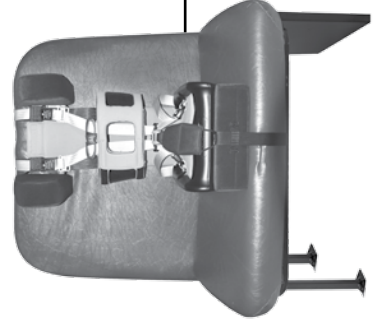

STAR Special Needs

- 25 - 105 lbs. (11.3 - 47.5 kg)
- 57 in. (144 cm) tall or less
- over 1 year of age

Table Of Contents

	Page
General Information	1
Registration Information	1
General Warnings	2
Features	2
Weight & Height Limitations	3
Installation	3
Securing Child	5
Chest Strap Option	7
Emergency Evacuation	7
STAR Special Needs Option	8
Care & Maintenance	back cover

Store this instruction manual under the STAR removable seat pad.

General Warnings

▲ WARNINGS

FAILURE TO FOLLOW THESE WARNINGS CAN RESULT IN SERIOUS INJURY OR DEATH. PLEASE READ AND FOLLOW ALL INSTRUCTIONS CAREFULLY.

- THIS RESTRAINT MUST ONLY BE USED ON SCHOOL BUS SEATS. ENTIRE SEAT DIRECTLY BEHIND MUST BE UNOCCUPIED OR HAVE RESTRAINED OCCUPANTS.
- DO NOT USE THIS RESTRAINT UNTIL YOU READ AND UNDERSTAND THE INSTRUCTIONS IN THIS MANUAL.
- FOLLOW ALL INSTRUCTIONS ON THE RESTRAINT AND IN THIS MANUAL.
- DO NOT MODIFY THIS RESTRAINT OR USE ANY ACCESSORIES OR PARTS SUPPLIED BY OTHER MANUFACTURERS. USE ONLY SAFEGUARD REPLACEMENT PARTS.
- NEVER USE THE RESTRAINT SYSTEM IF IT IS DAMAGED OR MISSING PARTS. DO NOT USE A CUT, FRAYED OR DAMAGED HARNESS OR SEAT BELT.
- DO NOT USE BLEACH OR HARSH CLEANSERS ON SEAT CUSHIONS, WEBBING OR BUCKLES.
- NEVER LUBRICATE THE SEAT BELT BUCKLES.
- A CHILD RESTRAINT SHOULD BE PROPERLY SECURED EVEN WHEN UNOCCUPIED SINCE AN UNSECURED CHILD RESTRAINT MAY INJURE OTHER OCCUPANTS IN A CRASH.

General Information

The SafeGuard team truly cares about child passenger safety and is committed to providing innovative restraints that offer the utmost in safety and ease of use. While no restraint can prevent injury in every situation, proper installation and use of a restraint can substantially reduce a child's risk of serious injury or death.

It is critical to read and understand these instructions and the vehicle manufacturer's instruction BEFORE using this restraint. Failure to properly use this restraint may result in serious injury or death of the child being transported. If you have any questions after reviewing the instructions, please contact us at:

SafeGuard Customer Service: www.safeguardseat.com (or) 1-877-447-2305.

This restraint system conforms to all applicable Federal Motor Vehicle Safety Standards.

Registration Information

Please fill out the prepaid registration card attached to the restraint and mail it today or register online at the website listed below.

Restraints could be recalled for safety reasons. You must register this restraint to be reached in a recall. Send your name, address, the restraint's model number, manufacturing date and serial number to IMM, 18881 U.S. 31 North, Westfield, IN 46074 or call 1-877-447-2305 or register online at www.safeguardseat.com/register.

For recall information, call the U.S. Government's Vehicle Safety Hotline at 1-888-327-4236 (TTY: 1-800-424-9153), or go to <http://www.NHTSA.gov>.

The restraint model number and manufacture date are located on a printed label sewn to the webbing above the seat base.

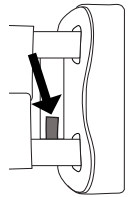

Features

STAR & STAR plus

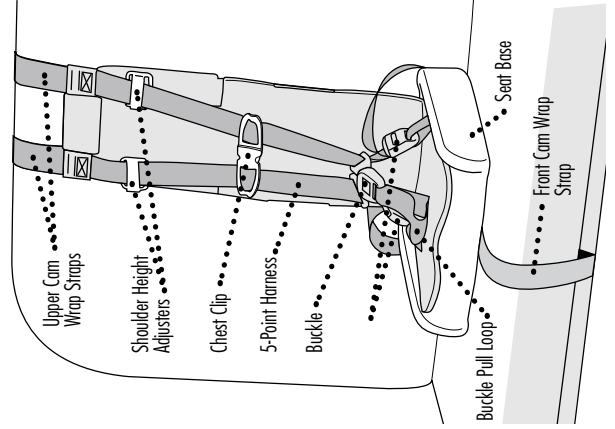

STAR Special Needs

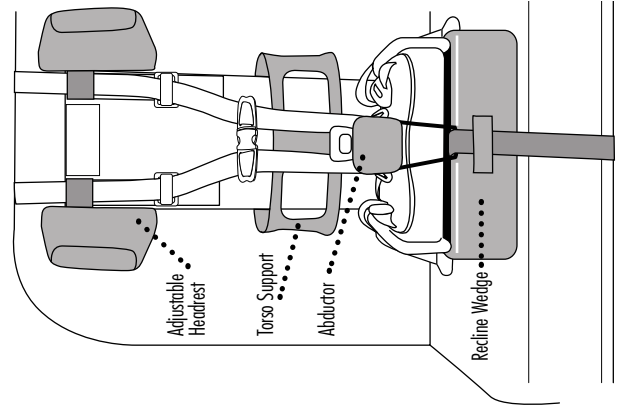

Weight & Height Limitations

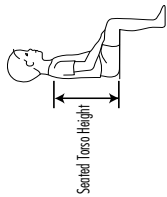

STAR

- 25 - 65 lbs. (11.3 - 29.5 kg)
- 57 in. (144 cm) tall or less
- over 1 year of age
- 20 in. (50 cm) or less seated torso height

STAR plus

- 25 - 105 lbs. (11.3 - 47.5 kg)
- 57 in. (144 cm) tall or less
- over 1 year of age
- 20 in. (50 cm) or less seated torso height

Installation on the school bus seat

Note: For STAR Special Needs, refer to the installation instructions on pages 8-10 first.

Important Note: STAR may be secured to a standard 222 school bus seat unless your state code requires that the seat be FMVSS 210 reinforced. Check your state codes.

⚠ WARNING! DEATH or SERIOUS INJURY can occur:

- Follow all instructions on the child restraint and in this manual. Failure to follow the manufacturer's warnings for proper use of this child restraint system can result in serious injury or death.

1. Position the STAR restraint on the bus seat. Place the three upper cam wrap straps around the top of the school bus seat back. Insert the two lower cam wrap straps through the opening at the rear of the school bus seat cushion. **A**

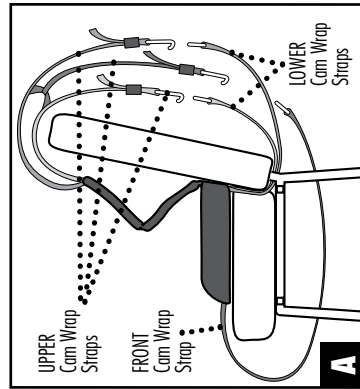

2. If the opening at the rear of the school bus seat cushion is blocked, lift the school bus seat cushion as shown in **B**. Thread the two lower cam wrap straps through the opening. Lower the seat cushion to its original position and lock into place. Be sure the lower cam wrap straps are not trapped within the seat cushion.

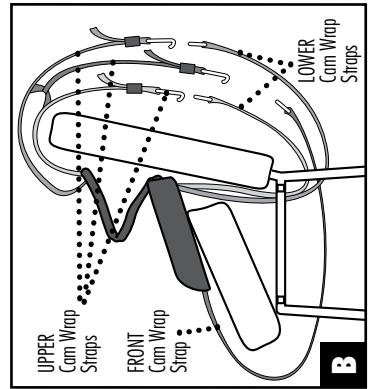

3. Connect the left upper cam wrap strap to the left lower cam wrap strap. Connect the right upper cam wrap strap to the right lower cam wrap strap. Pull adjuster straps to tighten both outside cam wraps. **C & D**

Important: Be sure to secure and tighten the two outer cam wrap straps before connecting the middle cam wrap strap. Proper tightening will compress the foam at the top of the school bus seat by approximately a half inch.

4. Connect the middle upper cam wrap strap to the front cam wrap strap. Pull adjuster strap to tighten. **E**

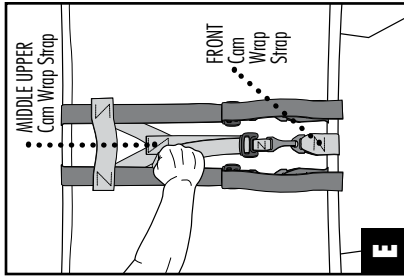
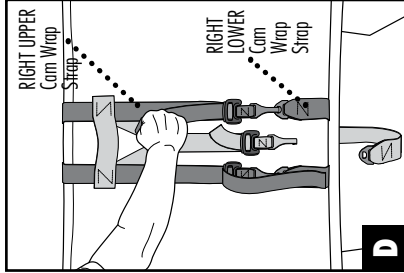
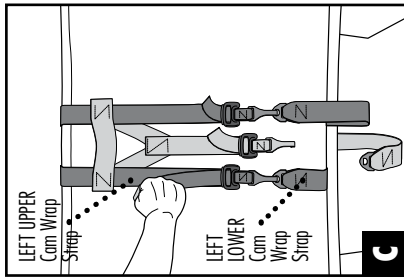

5. Verify the security of the restraint by moving the rear of the seat base sideways. It should move less than an inch.

6. Once all straps are tight and secured, use the plastic keeper on each strap to secure the free ends of the three upper cam wrap straps. **F**

Important: Straps must appear as in **G** after installation is complete.

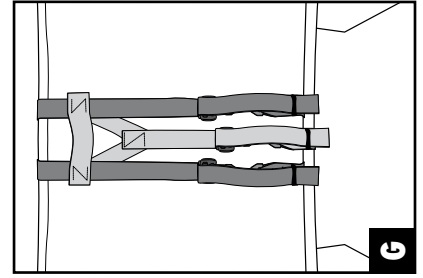
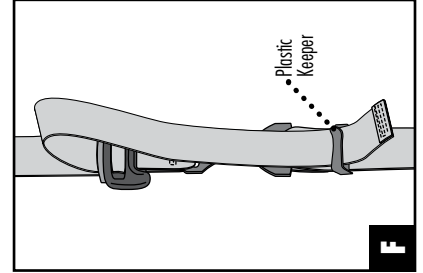

Securing the Child

A WARNING! DEATH or SERIOUS INJURY can occur:

- Follow all instructions on the child restraint and in this manual. Failure to follow the manufacturer's warnings for proper use of this child restraint system can result in serious injury or death.
- Backpacks must be removed before using the STAR restraint.
- Snugly adjust the belts provided with this restraint around the occupant.

1. Prepare harness:

- Loosen harness: Push left harness adjuster button and pull up on left shoulder strap. **A** Repeat with right shoulder strap.
- Open chest clip and unbuckle harness.
- Lay buckle flat, toward front of restraint.

2. Place child in restraint: **B**

- Place child in restraint with child's back flat against the back of the restraint.
- Remove any twists from harness straps.
- Position harness shoulder straps over child's shoulders.

3. Buckle harness:

- Use buckle pull loop to pull buckle away from child.
- Make sure harness straps are not twisted.
- Insert buckle tongues into harness buckle. Listen for an audible click when each buckle tongue is fastened. **C**
- Check buckle connection is secure by pulling on shoulder straps.

4. Tighten harness:

- Pull free end of harness strap, located on the outside of child's leg, until harness is snug around the child. **D**
- Repeat with second harness strap.
- A snug strap should not allow any slack. It lies in a relatively straight line without sagging. It does not press on the child's flesh or push the child's body into an unnatural position.
- Be sure the harness is snug and tight on both the thighs and chest before each use.

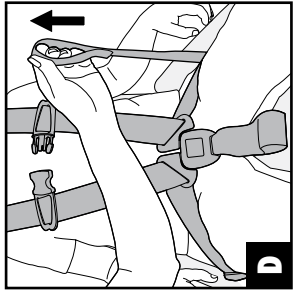
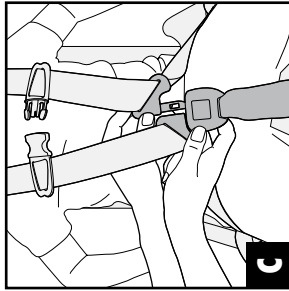
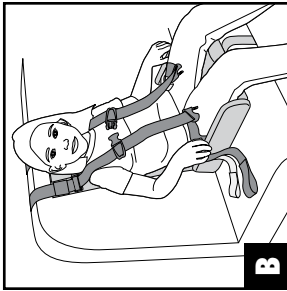
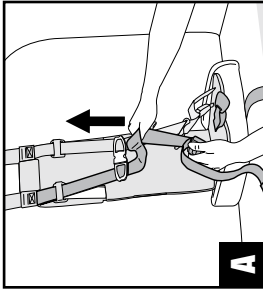

5. Fasten harness chest clip: **E**

- Fasten chest clip by pushing both sides together.
- Position chest clip at middle of child's chest, at armpit level.

6. Adjust harness height:

- Position each yellow shoulder height adjuster at or just above child's shoulder. **F**

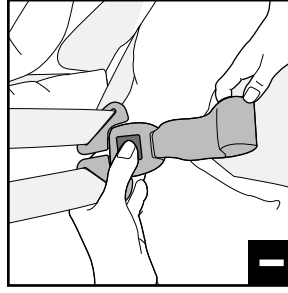
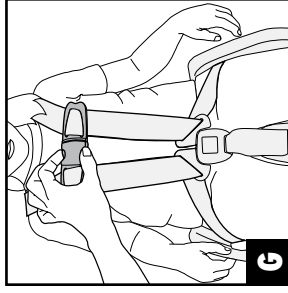
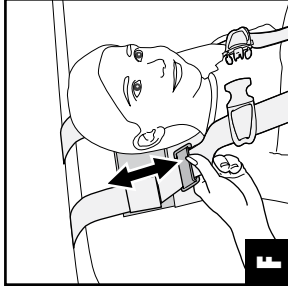
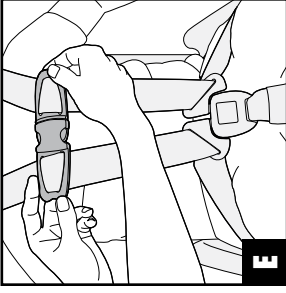

To remove child from the child restraint: **G**

- Open chest clip by squeezing middle tabs and pulling apart. **G**
- Loosen harness: Pull shoulder strap up while pushing button on harness adjuster located on outside of child's leg. Repeat with second harness strap. **H**
- Use buckle pull loop to pull buckle and buckle pad away from child. Unbuckle harness buckle by pressing down on red release button. **I**
- Remove child.
- Rebuckle harness to prevent twisting of the straps.

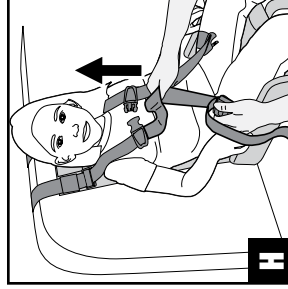

Chest Strap option

For STAR and STAR *plus*

A WARNING! DEATH or SERIOUS INJURY can occur:

- Orange chest strap is for positioning assistance only and is not a restraint device.
- Orange chest strap may not be substituted for shoulder straps or any other portion of STAR restraint.
- Orange chest strap should be used only in addition to the full harness.
- Orange chest strap must be placed under the shoulder straps.

The STAR chest strap is designed to provide positioning assistance for children with special needs.

Chest Strap Option Installation:

- 1.** Position the optional orange chest strap around the child's chest. Proper position of orange chest strap is at the middle of child's chest, at armpit level.
- 2.** Fasten the orange chest strap buckle and adjust the strap snugly. A snug strap should not allow any slack. It lies in a relatively straight line without sagging. It does not press on the child's flesh or push the child's body into an unnatural position. **A**
- 3.** Properly secure the child in the STAR restraint system. **B**

Important: Orange chest strap must be placed under the shoulder straps.

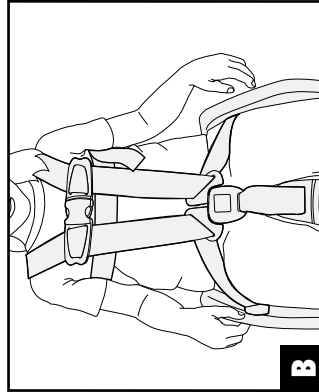
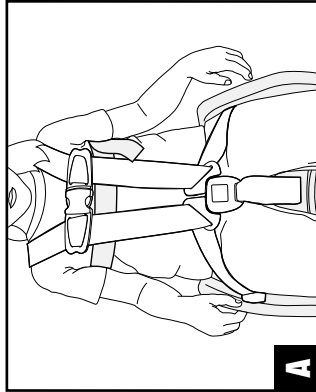

Emergency Evacuation

For STAR and STAR *plus*

The STAR restraint system is designed to remain operational after most crash situations. In the event of a crash or an event that necessitates an emergency evacuation, follow this procedure.

- 1.** Open chest clip by squeezing middle tabs and pulling apart.
- 2.** Unbuckle harness buckle by pressing down on red release button.
- 3.** If not possible to perform Steps 1 and 2, use a belt cutter to cut shoulder webs below chest clip. **A** If optional orange chest strap is being used, cut chest strap on right side of child. **A**
- 4.** Remove child.

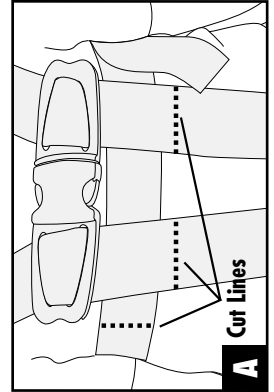

STAR Special Needs

- Weight Range: 25 - 105 lbs. (11.3 - 47.5 kg)
Standing Height: 57 in. (144 cm) or less
Seated Torso Height: 20 in. (50 cm) or less

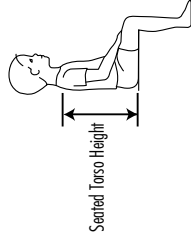

Restraint Features

The STAR Special Needs restraint is equipped with additional features as shown below to provide support for children with special health care needs.

The STAR Special Needs restraint features may be used in any combination based on the child's needs.

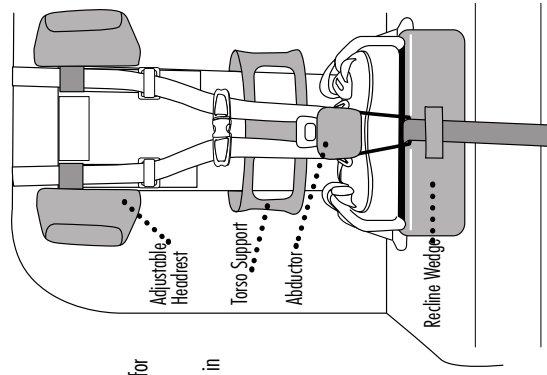

Recline Wedge

The recline wedge is used to provide additional lower torso support as needed.

Recline Wedge Installation:

- 1.** Verify adhesive-backed velcro strips are on bottom of seat base. If missing replace with new strips.
 - 2.** Position the recline wedge on the bus seat with the tallest side facing the front of the bus seat. Be sure to align the hook and loop fasteners on the bottom of the seat base and the top of the recline wedge. **A**
 - 3.** Thread the front black cam wrap strap through the webbing sewn onto the front of the recline wedge. **A**
 - 4.** Follow the STAR installation instructions on page 3 to complete the installation of the restraint to the bus seat. **A**
- Installation Tip:** When using both the abductor and the recline wedge, first thread the front black cam wrap strap through the elastic strap sewn onto the front of the abductor then through the webbing sewn onto the front of the recline wedge.

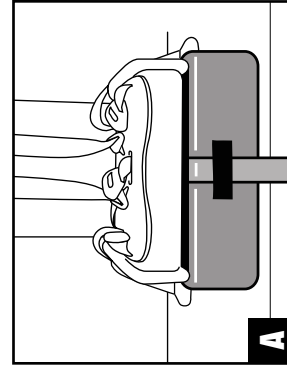

STAR Special Needs continued

Headrest

The width and height of the headrest are both adjustable to provide additional support for the child's head.

Headrest Installation:

1. Adjust headrest width if necessary. (See instructions below.)
2. Orient the STAR Special Needs restraint so the back of the shoulder harness faces up.
3. Position the headrest such that the I-shaped openings are centered on the exposed black webbing. **A**
4. Grasp the black webbing and pull it through the first I-shaped opening. Repeat with the second I-shaped opening. **B**

Headrest Width Adjustment:

1. Remove the headrest from the STAR Special Needs restraint.
2. Open the two fabric tabs on the back of the headrest cover.
3. Detach the vinyl tab from the attach tab.
4. Detach the elastic strap from the attach tab.
5. Remove the plastic headrest panel from the headrest cover and foam.
6. Select Slot 1 for a wide width headrest or Slot 2 for a narrow width headrest. **C**
7. Insert the plastic headrest panel into the selected slot.
8. Reattach the elastic strap to the attach tab. **D**
9. Reattach the vinyl tab using Hole 1 for wide width or Hole 2 for narrow width. **D**
10. Close the two fabric headrest cover tabs.
11. Repeat steps 2-10 for the opposite side of the headrest.

Headrest Height Adjustment:

After the STAR Special Needs restraint is installed on the bus seat, grasp both sides of the headrest and slide it up or down to provide proper support for the child's head. **E**

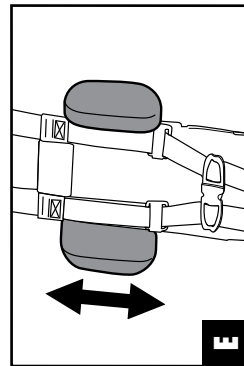
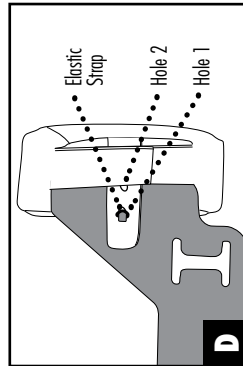
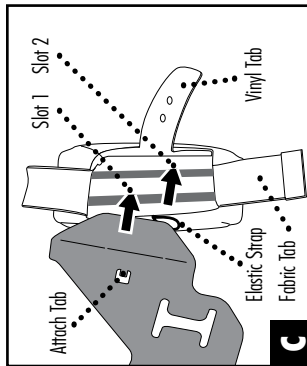
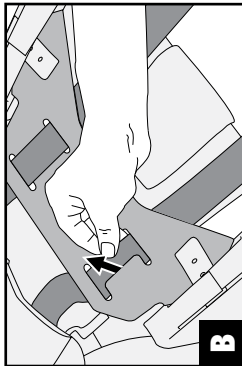
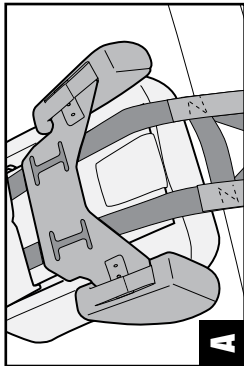

STAR Special Needs continued

Abductor

The abductor is used to provide additional leg support as needed.

Abductor Installation:

1. Unbuckle the harness buckle.
2. Position the abductor on the restraint in front of the buckle with the widest portion of the abductor facing the front of the bus seat.
3. Thread the buckle through the webbing sewn onto the back of the abductor. **A**
4. Thread the front black cam wrap strap through the elastic strap sewn onto the front of the abductor. **B**
5. Follow the STAR installation instructions on page 3 to complete the installation of the restraint to the bus seat.

Installation Tip: When using both the abductor and the recline wedge, first thread the front black cam wrap strap through the elastic strap sewn onto the front of the abductor then through the webbing sewn onto the front of the recline wedge.

Torso Support

A WARNING! DEATH or SERIOUS INJURY can occur:

- Torso support is for positioning assistance only and is not a restraint device.
- Torso support may not be substituted for shoulder straps or any other portion of STAR restraint
- Torso support should be used only in addition to the full harness
- Torso support must be placed under the shoulder straps

The torso support is used to provide additional support to the upper torso as needed.

Torso Support Installation:

1. Follow the STAR installation instructions on page 3 to complete the installation of the restraint to the bus seat.
2. Open the torso support and thread it between the restraint and the bus seat. **A**
3. Position and secure the torso support around the child using the hook and loop fastener.
4. Position and secure the child in the restraint following the STAR instructions. Be sure the harness is snug and tight on both the thighs and chest before each use.

Important: Torso support must be placed under shoulder straps.

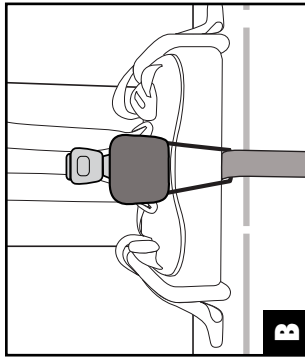
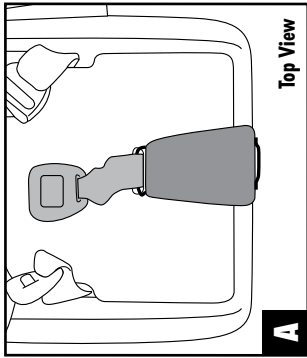

- **Base Seat**
with or without Lap Belt Restraints
- **Flex Seat**
with Lap-Shoulder Seat Belt Restraints
- **Two-Belt**
with Lap-Shoulder Seat Belt Restraints
- **Integrated Child Seat**
with or without Seat Belt Restraints
- **Options**
LATCH
Upper Torso Control Device



Base XChange Seat

Base school bus seat ready to convert

For all occupants (children under age of 5 should use age/size appropriate FMVSS 213 restraint system)



XChange FlexSeat

with Lap-Shoulder Seat Belt Restraints

For all occupants greater than 40 lbs (18 kg) and 40 in. (102 cm) tall



XChange Two-Belt

with Lap-Shoulder Seat Belt Restraints

For all occupants greater than 40 lbs (18 kg) and 40 in. (102 cm) tall



XChange Integrated Child Seat

with or without Lap/Lap-Shoulder Belt Restraints

For all occupants over 1 year of age, between 22 - 85 lbs. (10 - 39 kg) and 49 in. (124 cm) or less tall

Table Of Contents

	Page
General Information	1
Registration Information	1
General Warnings.....	2
Seat Features and Options	2
FlexSeat (Use for 2 or 3 children).....	3
Using Lap-Shoulder Belts.....	4
Integrated Child Seat Option.....	6
Installation of Add-On Child Seats	7
LATCH (Lower Anchors & Tether) Option.....	8
Upper Torso Control Device Option.....	9
Care and Maintenance.....	10

Store this instruction manual behind the ICS removable seat pad (if equipped) or with the vehicle for future reference.

General Information

The SafeGuard team truly care about child passenger safety and are committed to providing innovative restraints that offer the utmost in safety and ease of use. While no restraint can prevent injury in every situation, proper installation and use of a restraint can substantially reduce a child's risk of serious injury or death.

Follow all the instructions of this manual and the instructions of the vehicle manufacturer. Failure to properly use this restraint may result in serious injury or death of the child being transported. If you have any questions after reviewing the instructions, please contact us at:

SafeGuard Customer Service: www.safeguardseat.com or 1-877-447-2305.

This restraint system conforms to all applicable Federal Motor Vehicle Safety Standards.

Registration Information - For Aftermarket Seats

Please fill out the prepaid registration card attached to the bus seat and mail it today or register online at the website listed below.

Restraints could be recalled for safety reasons. You must register this restraint to be reached in a recall. Send your name, address, and the restraint's model number, manufacturing date, and serial number to IMMI, 18881 U.S. 31 North, Westfield, IN 46074 or call 1-877-447-2305 or register online at www.safeguardseat.com/register.

For recall information, call the U.S. Government's Vehicle Safety Hotline at 1-888-327-4236 (TTY: 1-800-424-9153), or go to <http://www.NHTSA.gov>.

The seat model number and manufacture date are located on a label that is on the lower seat frame. Lift open seat cushion to view label (see illustration "A"). The lap-shoulder belt restraint system part number is located on a label sewn to the end of the web at the belt anchorage (see illustration "B").

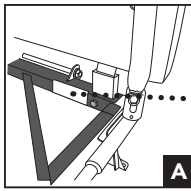

Seat model number and manufacture date

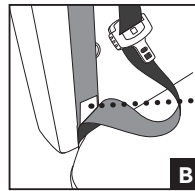

Lap-shoulder belt restraint system part number

General Warnings

⚠ WARNING! DEATH or SERIOUS INJURY can occur:

Failure to follow these warnings can result in serious injury or death. Please read and follow all instructions carefully.

- Follow all instructions on the bus seat and in this manual.
- Do not modify this seat and restraint or use any accessories or parts supplied by other manufacturers. Use only SafeGuard replacement parts.
- Never use the restraint system if it is damaged or missing parts. Do not use a cut, frayed, or damaged harness or seat belt. Replace harness or seat belt immediately.
- Do not use bleach or harsh cleansers on seat cushions, webbing, or buckles. Never lubricate the seat belt buckles.

Seat Features and Options

Base XChange Seat

Standard FMVSS 222 Seat Back
(readily converts to other seat versions)

FMVSS 210 Lap Belt/
Lap-Shoulder Belt
Ready Frame



XChange FlexSeat

Shoulder Height Adjuster

Locking Latch Plate

Lap-Shoulder Belt Restraint

Seat Belt Buckles

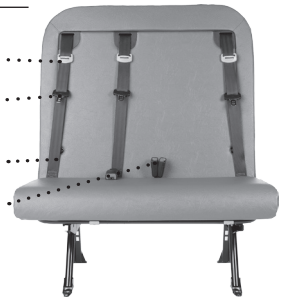

Two-Belt Seat/ Integrated Child Seat

Shoulder Height Adjuster

Locking Latch Plate

Integrated Child Seat
(stowed position)

Seat Belt Buckles

Upper Torso Control Device
Attachment Latch Plates
(optional)

Integrated Child Seat
(ready for use position)

Lap-Shoulder Seat Belt Restraint

Lower LATCH Anchors
(optional)

Tether Anchor
(for add-on child seats
on pedestal)

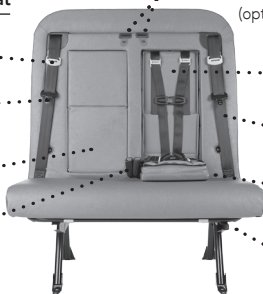

Seat Mounting Options

- Pedestal/Wall
- Pedestal/Pedestal
- Track Seating

FlexSeat with Lap-Shoulder Seat Belt Restraints

Use for 2 or 3 children

This seat with lap-shoulder belt restraint system conforms to all applicable Federal Motor Vehicle Safety Standards.

⚠ WARNING! DEATH or SERIOUS INJURY can occur:

- Follow all instructions on the restraints and in this manual. Failure to follow the manufacturer's warnings for proper use of this restraint system can result in serious injury or death.
- Use all seating positions only with occupants who are at least 4 years old and weigh 40 pounds (18 kg) or more and whose height is 40 inches (102 cm) or more.
- Shoulder height adjuster must be at or above the top of occupant's shoulder.
- The hip of the child in the aisle seat must not extend beyond the edge of the seat cushion.
- Backpacks must be removed before using the lap-shoulder seat belt restraints.
- Adjust the lap-shoulder belts snugly around the occupant.

The SafeGuard FlexSeat accommodates two or three children on a 39" school bus seat.

USE FOR 2 CHILDREN: Slide two buckles on right side **A1** all the way left to create two seating positions. **A2**

USE FOR 3 CHILDREN: Slide two buckles located on right side **A1** all the way right to create three seating positions. **A3**

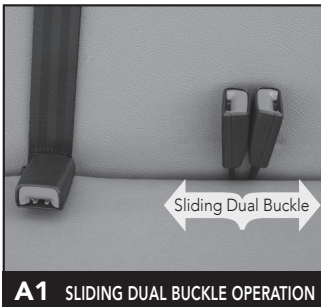

Using Lap-Shoulder Belts on a School Bus Seat



When to Wear the Lap-Shoulder Belt:

1. When the school bus is ready to begin or continue its trip.
2. Anytime the school bus is moving or on the roadway.

SafeGuard recommends use of an FMVSS 213 child restraint system for children under five (5) years of age.

BUCKLING UP

1. The passenger should sit as flat against the seat back as possible to achieve the best possible fit of the lap-shoulder belt on the passenger's upper and lower torso. **A**



2. Pull out shoulder belt webbing from the upper seat back. Do not let the belt get twisted. (The shoulder belt could possibly lock if pulled across the body too quickly. If this happens, let the belt retract slightly to unlock it. Then pull the belt across you more slowly.) **B**



3. Place the lap-shoulder belt over the shoulder and around the passenger's upper body. **C**



4. Insert the latch plate into the matching seat belt buckle on the lower seat cushion. **D**



CLICK

5. Listen for an audible click when the latch plate is fastened. **D**

TUG

6. Check that the buckle connection is secure by pulling on the shoulder portion of the lap-shoulder belt. **E**



7. Position the lap portion of the belt so that the webbing is below the passenger's waist, not over the stomach or abdomen area. The lap portion of the belt must be low and snug over the bony structure of the passenger's hips. **F**



SNUG

8. Pull up on the shoulder portion of the lap-shoulder belt to tighten the lap portion. **G**



IMPORTANT! This step must be done to assure proper fit of lap-shoulder belt to passenger!

The shoulder portion of the belt must be snug across the chest and in the center of the passenger's shoulder. **H**



9. Position the shoulder height adjuster at or just above the passenger's shoulder. The shoulder belt should not cross the passenger's face or neck. **I**



10. Make sure the lap-shoulder belt is snug and lies flat against the passenger. There should be no twisting of the webbing. **J**



UNBUCKLING

1. Push the red buckle release button and remove the latch plate from the buckle. The buckle has a release mechanism that separates the latch plate from the buckle. **A**
2. Allow the shoulder belt to retract and stow in the upper seat back.
3. As a courtesy to the next passenger, move the shoulder height adjuster up to its highest position. **B**



Using Lap-Shoulder Belts on a School Bus Seat

Examples of Improper Usage

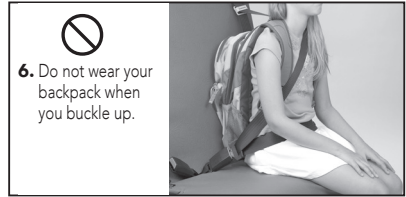
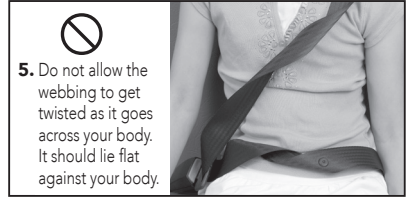

Integrated Child Seat Option

This child restraint system conforms to all applicable Federal Motor Vehicle Safety Standards.

⚠ **WARNING!** DEATH or SERIOUS INJURY can occur:

- Follow all instructions on the child restraint and in this manual. Failure to follow the manufacturer's warnings for proper use of this child restraint system can result in serious injury or death.
- Use only with children who weigh between 22 and 85 pounds (10 and 39 kg) and whose height is 49 inches (124 cm) or less and who are over 1 year of age.
- Top portion of the seat cushion must be folded under lower portion of seat cushion to form seating surface for child.
- Adjust the belts provided with this child restraint snugly around your child.

1. Activate the restraint system by lowering the two-piece seat cushion. **Fold the top portion of the cushion under the bottom portion to form a seating surface for the child.** **A** Be sure seat belt buckles (if equipped) are NOT beneath the two-piece cushion. Failure to fold the seat cushion under can result in damage to the restraint and thus improper restraint of the child.

Open chest clip by squeezing middle tabs and pulling chest clip apart.

Unbuckle harness buckle by pressing down on red release button.

To loosen harness, lift metal tab at top of seat ① and pull down on shoulder strap ② to loosen strap.

Repeat with second shoulder strap.

2. Place the child in the restraint with the child's back flat against the back of the bus seat cushion. Position shoulder straps over the child's shoulders.

Buckle harness **B** by inserting buckle tongues into harness buckle ③.

Listen for an audible click when each buckle tongue is fastened.

Check the buckle connection is secure by pulling on the shoulder straps.

3. To tighten harness, pull down equally on top straps ④ on both sides until the harness is snug around the child. **C**

A snug strap should not allow any slack. It lies in a relatively straight line without sagging. It does not press on the child's flesh or push the child's body into an unnatural position.

4. Fasten chest clip ⑤ by pushing both sides together.

Position chest clip at middle of the child's chest, at armpit level. **D**

Position each shoulder height adjuster ⑥ at or just above the child's shoulder.

Be sure harness is snug and tight on child's thighs and chest.

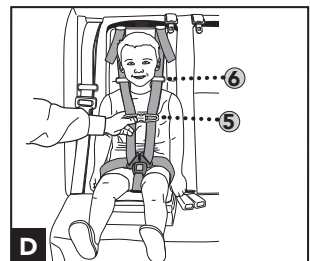
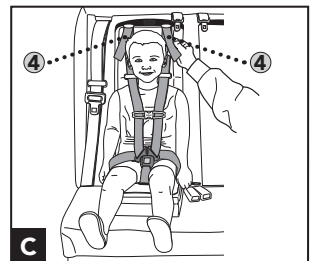
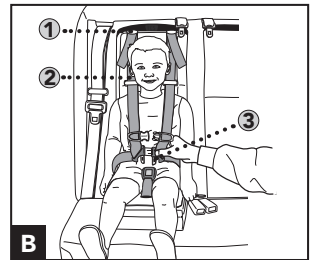
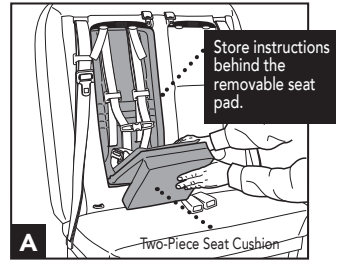

Installation of Add-On Child Seats

⚠ WARNING! DEATH or SERIOUS INJURY can occur:

- Follow all manufacturer's instructions found in the child restraint user's manual and in this manual. Failure to follow the manufacturer's warnings for proper use of the child restraint system can result in serious injury or death.
- NHTSA seating space guidelines should be followed when a child seat is installed.

Important: The SafeGuard XChange School Bus seat with lap-shoulder belts utilizes an Emergency Locking Retractor (ELR) with a locking latch plate on the belt. This system does not require the use of the child seat manufacturer's supplied locking clip.

Rear facing Infant or Convertible Child Seats

The rear facing infant or convertible child seat may be installed with either the lap shoulder belt restraint system **A** or with the LATCH system **B** (if XChange seat and add-on child seat are equipped with LATCH hardware and components).

For attachment of the add-on child seat with the XChange seat lap-shoulder belt restraint system, carefully read and follow the add-on child seat manufacturer's installation instructions for the correct belt path on the child seat and how to tighten the seat down.

For attachment of the add-on child seat using the LATCH system, carefully read and follow the add-on child seat manufacturer's installation instructions for the correct LATCH attachment procedure and how to tighten the seat down.

Forward Facing Child Seats

Forward facing child seats may be installed with either the lap shoulder belt restraint system **C** or with the LATCH system (if XChange seat and add-on child seat are equipped with LATCH hardware and components).

For attachment of the add-on child seat with the XChange seat lap-shoulder belt restraint system, carefully read and follow the add-on child seat manufacturer's installation instructions for the correct belt path on the child seat and how to tighten the seat down.

For attachment of the add-on child seat using the LATCH system, carefully read and follow the add-on child seat manufacturer's installation instructions for the correct LATCH attachment procedure and how to tighten the seat down.

The forward facing add-on child seat tether strap may be used to provide additional securement for the child seat. Carefully read and follow the add-on child seat manufacturer's installation instructions for the correct use of the tether strap and see page 8 of this manual for instructions regarding tether attachment.

Booster Seats

DO NOT USE add-on booster seats on lap-shoulder belt school bus seats! **D**
The lap-shoulder belt is adjustable to fit a child and meets FMVSS 213 built-in booster seat requirements.

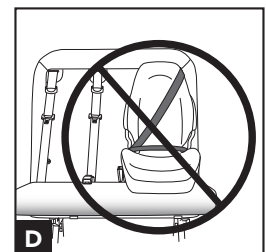
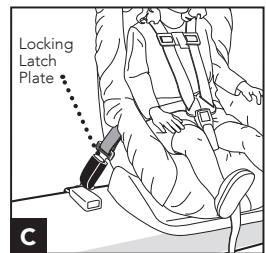
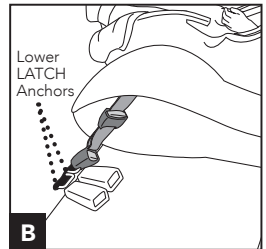
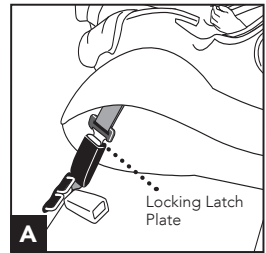

LATCH (Lower Anchors & Tether) Option

For Use with Add-On Child Seats

⚠ WARNING! DEATH or SERIOUS INJURY can occur:

- Follow all instructions on the child restraint and in this manual. Failure to follow the manufacturer's warnings for proper use of the child restraint system and LATCH attachments can result in serious injury or death.

Location and Use of Lower LATCH Anchors

Some SafeGuard Bus Seats are equipped with lower LATCH anchors for the attachment of add-on child seats. The lower LATCH anchors (if available) are located in the lower portion of the back seat cushion. **A** XChange Seat versions equipped with lap-shoulder belts and/or integrated child seats will have LATCH anchor locations identified with the anchorage symbol **A1** just above the anchor.

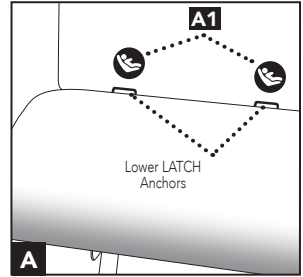

Adding LATCH Anchors

Base XChange Seats may be fitted with LATCH anchors if not originally equipped. Contact your OEM Bus Dealer or SafeGuard for further information on ordering LATCH anchors.

If LATCH anchors are required to be added to XChange seats originally equipped with either lap-shoulder belt or integrated child seat options, the entire SmartFrame module must be exchanged. Contact your OEM Bus Dealer or SafeGuard for further information on ordering inner module assemblies equipped with LATCH anchors.

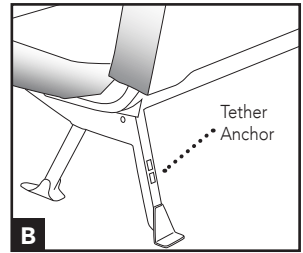

Location and Use of Tether Anchors

All SafeGuard XChange Bus Seats are equipped with tether anchors for add-on child seats. Tether anchors are located on the aisle side rear pedestal and on the seat wall mount bracket rear edge. **B**

Installing Tether

To attach an add-on child seat tether, route the tether on the child seat over the top of the SafeGuard Bus Seat. **C** Extend the tether and connect the snap hook to the nearest tether anchor provision at the lower rear of the seat. **D** Adjust the tether to a snug and tight fit by pulling on the free end of the strap at the adjuster. **D**

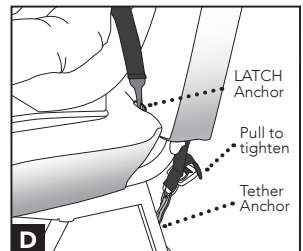

Upper Torso Control Device Option

Seat must have LATCH and lap-shoulder belts to use upper torso control device. Upper tongues must be installed to seat.

This system conforms to all applicable Federal Motor Vehicle Safety Standards.

▲ WARNING! DEATH or SERIOUS INJURY can occur:

- Follow all instructions on the restraint and in this manual. Failure to follow the manufacturer's warnings for proper use of this restraint system can result in serious injury or death.
- Use only with occupants who are at least 4 years old and weigh 40 pounds (18 kg) or more and whose height is 40 inches (102 cm) or more.
- Never use the Upper Torso Control Device without the lap-shoulder seat belt restraint.
- Snugly adjust the belts provided with this restraint around the occupant.

1. Place the occupant in the bus seat with the occupant's back flat against the back of the seat.

Secure lap-shoulder belt restraint ① on occupant per buckling instructions on page 4 of this manual. **▲**

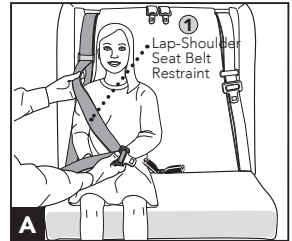

2. Fasten the buckle of the upper torso control device ② to the attachment location at the top of the seat. **B**

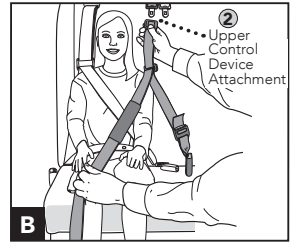

3. Position the first upper torso strap without the warning label behind the occupant's shoulder and attach the connector to the lower LATCH anchor ③ located directly below the upper attachment point. **C**

Listen for an audible click when the connector is attached.

Pull the free end of the first upper torso strap ④ to tighten and remove any slack. **C**

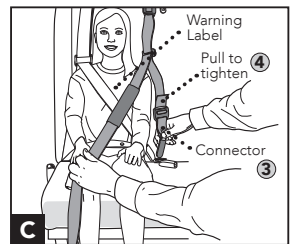

4. Position the second upper torso strap with the warning label over the occupant's shoulder and attach the second connector ⑤ to the lower LATCH anchor located on the opposite side of the occupant as shown. **D** Listen for an audible click when the connector is attached.

Position the shoulder height adjuster ⑥ on the upper torso control device at or just above the occupant's shoulder. Pull the free end of the second upper torso strap ⑦ to remove slack and tighten. **D**

A snug strap should not allow any slack. It lies in a relatively straight line without sagging. It does not press on the child's flesh or push the child's body into an unnatural position.

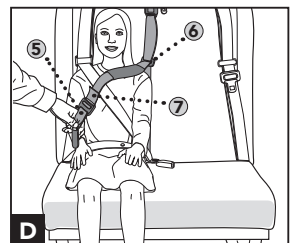

Care and Maintenance

- Care and maintenance of the SafeGuard Bus Seat is the responsibility of the owner of the SafeGuard Bus Seat.
- Clean seat cushions, webbing and buckle with a damp sponge using mild soap solution and lukewarm water. **Never use bleach or cleansers.**
- Never lubricate the seat belt buckle.

Seat Belt Inspection

Seats should be regularly inspected and after a crash:

- Inspect frame members and welds for damage, signs of failure or corrosion.
- Inspect that all attachment fasteners are present and secure.
- Inspect vinyl covering for cuts, tears or punctures that expose seat cushion or seat back foam.
- Inspect foam for cuts or missing sections. Verify that no portion of seat frame can be felt through foam.
- Inspect for tight fit of seat cover over all foam. Replace foam if covering is loose or bagging.
- Replace foam if any localized collapse of foam exists.

If any of these conditions develop or exist on the SafeGuard XChange Bus Seat, it will require repair or replacement of the affected parts immediately, regardless the age of the seat. See your OEM School Bus dealer or authorized SafeGuard Bus Seat dealer for replacement parts.

Lap-shoulder seat belt restraints and integrated child seat restraints on the SafeGuard XChange Bus Seat should be regularly inspected and after a crash as follows:

- Inspect belt on entire system for cuts, fraying, abrasion, and extreme or unusual wear.
- Inspect buckle for proper operation by inserting latch plate and listening for an audible click. Verify the buckle is not damaged cracked or broken.
- Inspect latch plate for proper operation by inserting into buckle. Latch plate must insert smoothly and produce an audible click. Verify proper latching by tugging on the belt. Latch plate must not be worn, deformed, or corroded.
- Inspect seat belt height adjuster for damage. Move adjuster up and down. It must move freely.
- Inspect retractor operation. When pulled and released slowly, webbing must spool out and retract without locking.
- Inspect mounting hardware at each restraint attachment point. Hardware should be tight. Hardware must not be missing, rusted, corroded, or damaged.

If any of these conditions develop or exist on the SafeGuard XChange Bus Seat belt system, it will require replacement of the seat belt(s) immediately, regardless the age of the seat. See your OEM School Bus dealer or authorized SafeGuard Bus Seat dealer for seat belt replacement.

Seat Belt Reverse Lock-Up Correction

If during the seat installation process the lap-shoulder seat belt restraint becomes locked-up and cannot be pulled out, perform the following steps.

1. Move the shoulder height adjuster down.
2. Grasp the top of the shoulder belt webbing close to where it exits the top of the seat and above the shoulder height adjuster.
3. Pull the web with a constant even force, tight enough to allow web to retract back into the retractor in the seat.
4. Slowly release the web. This should unlock the retractor.

User Assistance

For assistance using the SafeGuard Bus Seat, contact the OEM Bus dealer or IMMI/SafeGuard Customer Service at 1-877-447-2305.

SafeGuard Bus lap-shoulder seat belt restraints and child restraints are certified to applicable U.S. Federal Motor Vehicle Safety Standards FMVSS 209, 213, and 302. The SafeGuard Bus Seat, when properly installed per the instructions and with applicable hardware, allows the bus to meet U.S. Federal Motor Vehicle Safety Standards FMVSS 210, 222, and 225.

safeguardseat.com

SafeGuard ® School Bus Seating

Westfield, IN 46074-0408

Made in U.S.A.
SafeGuard Customer Service
1.877.447.2305

School Bus Child Restraint and Vehicle Manufacturer Contacts

School Bus Child Restraint Manufacturer Contacts

BESI, Inc.

9445 Sutton Place
West Chester, OH 45011
800-543-8222
www.besi-inc.com

E-Z-ON Products

605 Commerce Way West
Jupiter, FL 33458
800-323-6598
www.ezonpro.com

HSM Transportation Solutions

Formerly: CE White
417 N. Kibler Street
New Washington, OH 44854
Tel. 419-492-2157
www.hsmsolutions.com

IMMI

(SafeGuard)
18881 US 31 North
Westfield, Indiana 46074
877-447-2305
www.safeguardseat.com

SynTec Seating Solutions/S3C

200 Swathmore Ave.
High Point, NC 27263
Toll Free 866-931-7328
www.syntecseating.com

School Bus Manufacture Contacts

Blue Bird Corporation

PO Box 937
Fort Valley, GA 31030
478-822-2174

Collins Bus Corporation

PO Box 2946
Hutchinson, KS 67504-2946
620-662-9000

IC Corporation

4201 Winfield Road
Warrenville, Illinois 60555
800-892-7761

Lion Bus

921, chemin de la Rivière-du-Nord
Saint-Jérôme (Québec) J7Y 5G2
450-432-5466

Star Craft

2367 Century Drive
Goshen, IN 46528
574-642-3112

Thomas Built Buses, Inc.

1408 Courtesy Road
High Point, NC 27260
336-889-4871

Trans Tech Bus

7 Lake Station Road
Warwick, NY 10990
845-988-2333

DOT HS 810 906B

June 2015

