

U.S. DEPARTMENT OF TRANSPORTATION
NATIONAL HIGHWAY TRAFFIC SAFETY ADMINISTRATION

CALIBRATION TEST PROCEDURE
for
Part 572 Subpart P, HIII 3-Year-Old
Child Test Dummy



ENFORCEMENT
Office of Vehicle Safety Compliance
Mail Code: NVS-220, W43-481
1200 New Jersey Avenue, SE
Washington, DC 20590

TABLE OF CONTENTS

1.	PURPOSE AND APPLICATION	1
2.	GENERAL REQUIREMENTS.....	1
3.	SECURITY	2
4.	GOOD HOUSEKEEPING	3
5.	TEST SCHEDULING AND MONITORING.....	3
6.	TEST DATA DISPOSITION	3
7.	GOVERNMENT FURNISHED PROPERTY (GFP).....	3
8.	CALIBRATION AND TEST INSTRUMENTATION	6
9.	DEFINITIONS	7
10.	INSTRUMENTATION, TEST CONDITIONS, AND PROCEDURES.....	7
10.1	INSTRUMENTATION REQUIRED FOR QUALIFICATION TESTS (572.146)	7
10.2	OTHER TRANSDUCERS (S572.146)	8
10.2	TRANSDUCER TEST CONDITIONS	9
10.3	THORAX IMPACTOR PROBE (572.146(A))	9
10.4	GENERAL TEST CONDITIONS	13
11.	CALIBRATION TEST EXECUTION	13
11.1	HEAD CALIBRATION (572.142)	13
11.2	NECK CALIBRATION (572.143)	14
11.3	THORAX CALIBRATION (572.144)	16
11.4	TORSO CALIBRATION (S572.145).....	17
12.	POST TEST REQUIREMENTS.....	19
13.	REPORTS.....	19
13.1	APPARENT NONCONFORMANCE	19
13.2	FINAL PERFORMANCE CALIBRATION REPORTS	19
14.	DATA SHEETS	22
	DUMMY DAMAGE CHECKLIST	22
	EXTERNAL MEASUREMENTS.....	24
	HEAD DROP TEST (572.142)	30
	NECK FLEXION TEST (572.143).....	33
	NECK EXTENSION TEST (572.143)	35
	THORAX IMPACT TEST (572.144)	40
	TORSO FLEXION TEST (572.145)	44

LIST OF FIGURES

HANGER PLATE4
DUMMY HANGER5
SIGN CONVENTIONS FOR PART 572 TEST DUMMIES11
EXTERNAL DIMENSION MEASUREMENT DESIGNATIONS27
EXTERNAL DIMENSIONS TEST SETUP – FRONT VIEW.....28
EXTERNAL DIMENSIONS TEST SETUP – SIDE VIEW.....29
HEAD DROP TEST SET-UP SPECIFICATIONS.....32
PENDULUM SPECIFICATIONS37
NECK FLEXION TEST SET-UP SPECIFICATIONS38
NECK EXTENSION TEST SET-UP SPECIFICATIONS39
THORAX IMPACT TEST SET-UP SPECIFICATIONS.....42
PART 572P HYBRID III-3C THORAX CALIBRATION – HYSTERESIS43
TORSO FLEXION TEST SET-UP SPECIFICATION46

LIST OF TABLES

TABLE 1. DRAWING PACKAGE INDEX2
TABLE 2. SIGN CONVENTION FOR HYBRID III TRANSDUCER OUTPUTS.....12
TABLE 3. NECK-HEADFORM ASSEMBLY PENDULUM PULSE16

1. PURPOSE AND APPLICATION

The purpose of this laboratory procedure is to provide dummy users (independent testing laboratories under contract with the Office of Vehicle Safety Compliance (OVSC)) with standard test procedures for performing receiving-inspection and performance calibration tests on the Part 572, Subpart P dummy so that repetitive and correlative test results can be obtained. The following tests have been developed to establish a uniform calibration procedure for all users as the means of verifying the performance of the dummy.

- A. EXTERNAL DIMENSIONS (PADI)
- B. HEAD DROP TEST (572.142)
- C. NECK FLEXION TEST (572.143(b)(1))
- D. NECK EXTENSION TEST 572.143(b)(2)
- E. THORAX IMPACT TEST ((572.144)
- F. TORSO FLEXION (572.145)

National Highway Traffic Safety Administration (NHTSA) contract laboratories performing FMVSS 213 testing for the Office of Vehicle Safety Compliance (OVSC) must use this laboratory procedure for the calibration of Part 572, Subpart P dummies.

2. GENERAL REQUIREMENTS

Each Part 572, Subpart P dummy used in a compliance test must meet the specifications and performance criteria of Part 572 before each test in order to be an acceptable compliance test tool. The COTR will determine when post-test calibrations are necessary.

The Part 572, Subpart P Hybrid III, 3-Year-Old Child Dummy consists of components and assemblies specified in the drawing and specifications package which is available from www.regulations.gov under Docket No. NHTSA-2000-7051.

The Hybrid III 3-year-old Child Test Dummy (HIII-10C) is defined by drawings and specifications containing the following materials:

- (1) The engineering drawings and specifications contained in "Parts/Drawing List, Part 572 Subpart P, Hybrid III 3-year-old child crash test dummy (H-III3C), September 2001" (incorporated by reference, see §572.140), which includes the engineering drawings and specifications described in Drawing 210-0000, the titles of the assemblies of which are listed in Table 1, and,

(2) A manual entitled “Procedures for Assembly, Disassembly and Inspection (PADI), Subpart P, Hybrid III 3-year-old Child Crash Test Dummy, (H-III3C, Alpha Version) September 2001.”

TABLE 1. DRAWING PACKAGE INDEX

Component assembly	Drawing No.
(i) Head Assembly	210-1000
(ii) Neck Assembly	210-2001
(iii) Headform	TE-208-000
(iv) Upper/Lower Torso Assembly	210-3000
(v) Complete Leg Assembly—left	210-5000-1
(vi) Complete Leg Assembly—right	210-5000-2
(vii) Complete Arm Assembly—left	210-6000-1
(viii) Complete Arm Assembly—right	210-6000-2

3. SECURITY

All NHTSA Part 572, Subpart P test dummies delivered to the contract laboratory as Government Furnished Property (GFP) will be stored in a safe and secure area such as the dummy calibration laboratory. The contractor is financially responsible for any acts of theft and/or vandalism that occur during the storage of GFP. Any security problems shall be reported by telephone to the Industrial Property Manager (IPM), Office of Contracts and Procurement, within two working days after the incident. A letter containing specific details of the security problem will be sent to the IPM (with copy to the COTR) within 48 hours.

The contractor is responsible for maintaining the NHTSA test dummies in good working order, and shall protect and segregate the data that evolves from conducting Part 572, Subpart P dummy calibration tests before and after each compliance test.

No information concerning the Part 572, Subpart P dummy calibration data shall be released to anyone except the COTR, unless specifically authorized by the COTR or the COTR's Branch or Division Chief.

NOTE: No individuals, other than contractor personnel directly involved in the dummy calibration test program, shall be allowed to witness dummy calibration tests unless specifically authorized by the COTR.

4. GOOD HOUSEKEEPING

Contractors shall maintain the entire dummy calibration laboratory, test fixtures, and instrumentation in a neat, clean, and painted condition with test instruments arranged in an orderly manner consistent with good test laboratory housekeeping practices.

5. TEST SCHEDULING AND MONITORING

The Part 572, Subpart P dummies are being calibrated as test tools to be used in tests to determine compliance with the requirements of federal motor vehicle safety standards. The schedule for these performance calibration tests must be correlated with that of the compliance test schedule. All testing shall be coordinated to allow monitoring by the COTR.

6. TEST DATA DISPOSITION

The contractor shall make all dummy calibration data available to the COTR for review and analysis as required.

All backup data sheets, strip charts, recordings, plots, technician's notes, etc. shall be either sent to the COTR or destroyed at the conclusion of each delivery order, purchase order, etc.

7. GOVERNMENT FURNISHED PROPERTY (GFP)

Part 572, Subpart P test dummies will be furnished to the contract laboratory by the OVSC. The dummies shall be stored in an upright sitting position with the weight supported by the internal structure of the pelvis. The dummies head shall be held upright by using a strap around the chest or the base of the neck so that the neck is not supporting the weight of the dummy. Refer to Appendix A for an example storage device. These dummies shall be stored in a secured room that is kept between 55°F and 85°F. The contractor will check dummy components for damage after each test and complete a dummy damage checklist that will be included with the posttest dummy calibration. The COTR will be kept informed of the dummies condition in order that replacement parts can be provided.

HANGER PLATE

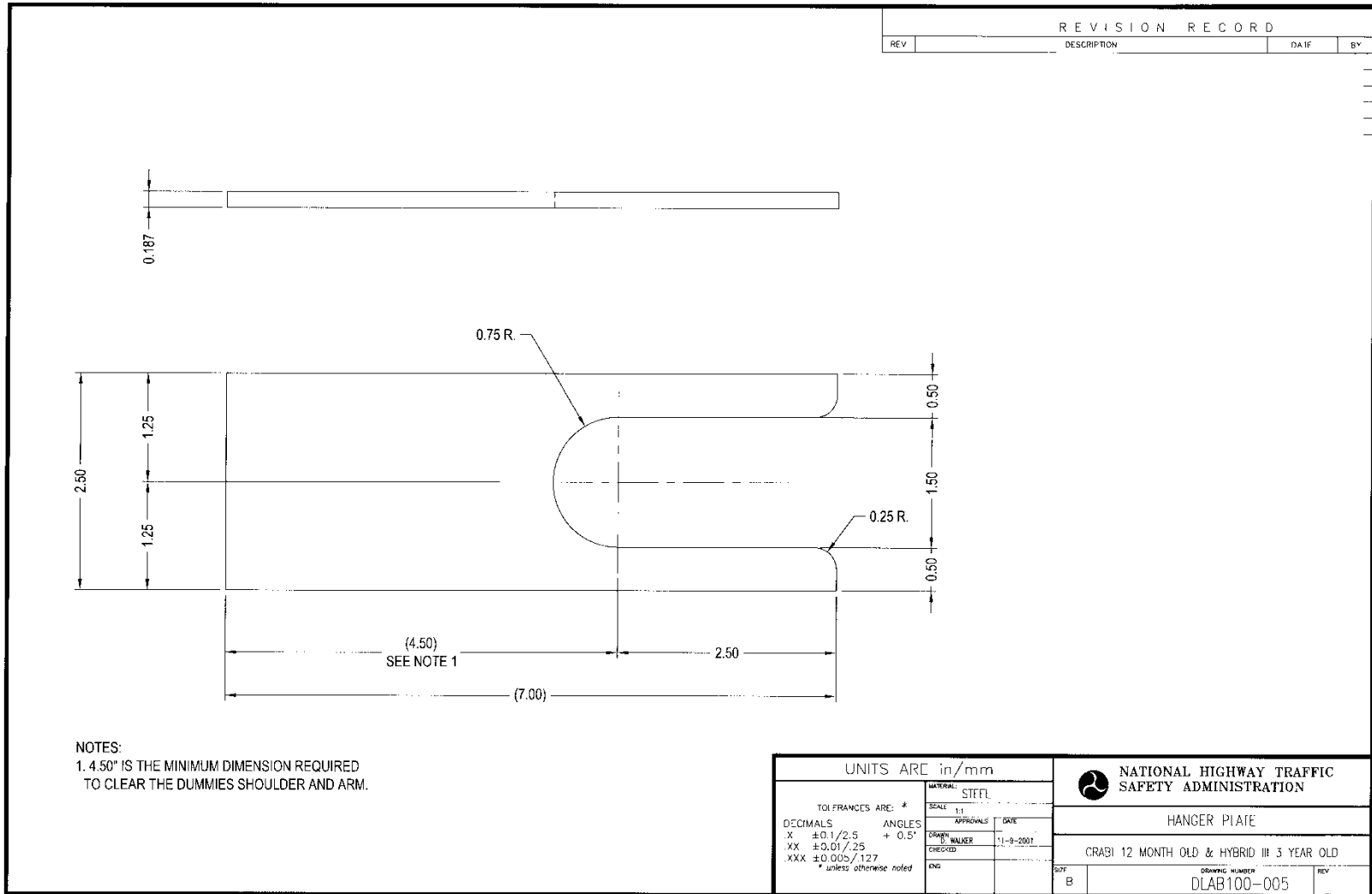

FIGURE 1

DUMMY HANGER

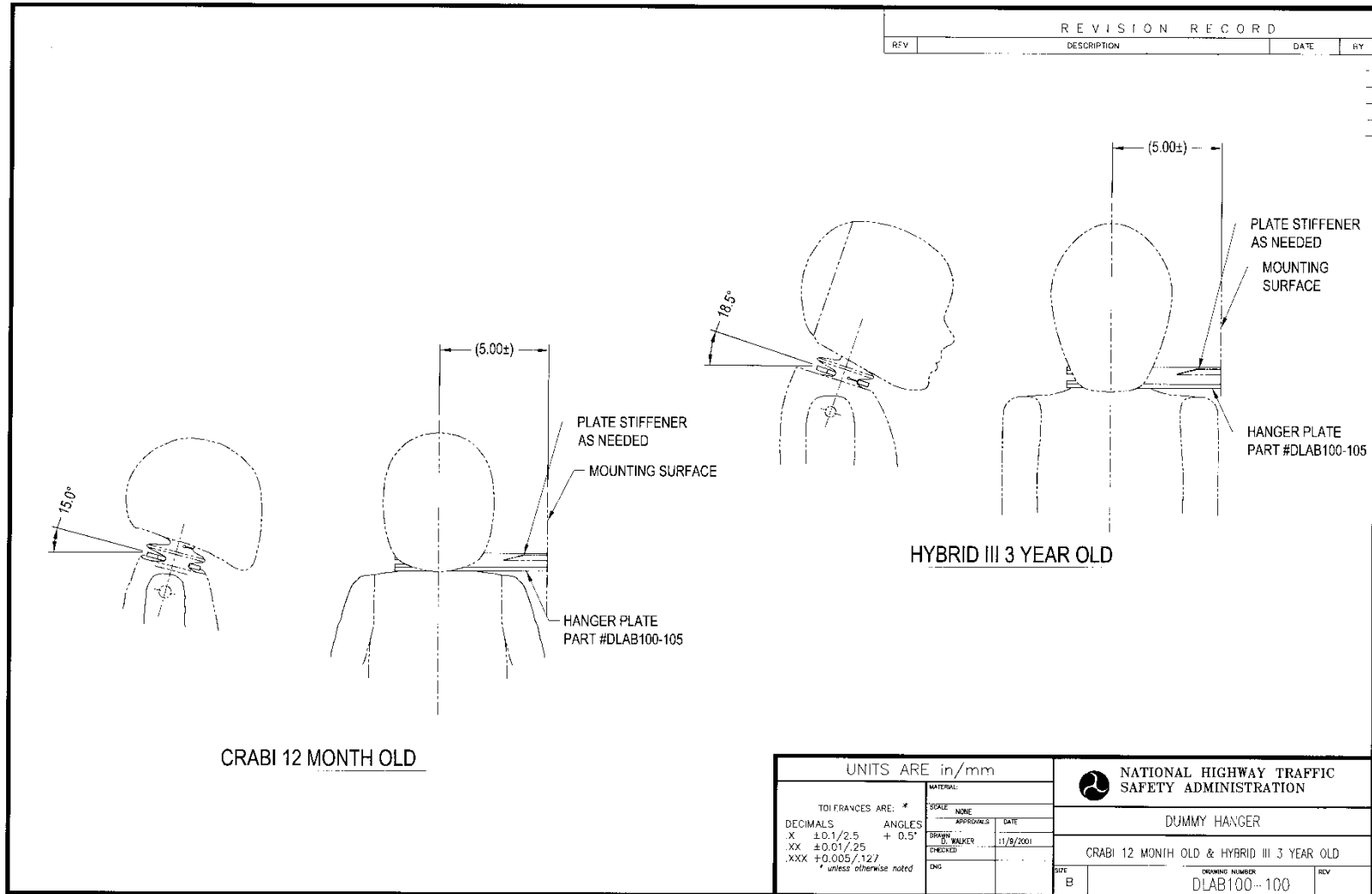

FIGURE 2

8. CALIBRATION AND TEST INSTRUMENTATION

Before the contractor initiates the dummy performance calibration test program, a test instrumentation calibration system must be implemented and maintained in accordance with established calibration practices. The calibration system shall be set up and maintained as follows:

- A. Standards for calibrating the measuring and test equipment shall be stored and used under appropriate environmental conditions to assure their accuracy and stability.
- B. All measuring instruments and standards shall be calibrated by the contractor, or a commercial facility, against a higher order standard at periodic intervals not exceeding 6 months for instruments and 12 months for calibration standards. Records, showing the calibration traceability to the National Institute of Standards and Technology (NIST), shall be maintained for all measuring and test equipment.
- C. All measuring and test equipment and measuring standards shall be labeled with the following information:
 - (1) Date of calibration
 - (2) Date of next scheduled calibration
 - (3) Name of the technician who calibrated the equipment
- D. The contractor shall provide a written calibration procedure that includes, as a minimum, the following information for all measurement and test equipment:
 - (1) Type of equipment, manufacturer, model number, etc.
 - (2) Measurement range
 - (3) Accuracy
 - (4) Calibration interval
 - (5) Type of standard used to calibrate the equipment (calibration traceability of the standard must be evident)
 - (6) The actual procedures and forms used to perform calibrations.
- E. The contractor shall keep records of calibrations for all test instrumentation in a manner that assures the maintenance of established

calibration schedules. All such records shall be readily available for inspection when requested by the COTR. The calibration system will need the written acceptance of the COTR before testing begins.

- F. Test equipment shall receive a calibration check immediately prior to each test. This check shall be recorded by the test technician(s) and made available if requested by the COTR.

9. DEFINITIONS

PADI- Procedures for Assembly, Disassembly, and Inspection

10. INSTRUMENTATION, TEST CONDITIONS, AND PROCEDURES

10.1 INSTRUMENTATION REQUIRED FOR QUALIFICATION TESTS (572.146)

The contractor shall provide¹ and install the following instrumentation to the GFP dummies for qualification testing and if required, for compliance testing. The instrumentation used during the compliance tests shall be those installed during qualification testing.

- A. HEAD – The head accelerometers shall have dimensions, response characteristics and sensitive mass locations specified in drawing SA572-S4 and be mounted in the head as shown in drawing 210-0000. (572.146(b))

Three accelerometers shall be mounted in the head cavity to measure orthogonal accelerations (A_x , A_y , A_z) at the center of gravity (CG) of the head assembly.
- B. NECK – The upper neck force transducer shall have the dimensions, response characteristics, and sensitive axis locations specified in drawing SA572-S19 and shall be mounted at the upper neck transducer location as shown in drawing 210-0000. (572.146(c))
- C. CHEST – The chest accelerometers shall have the dimensions, response characteristics, and sensitive mass locations specified in drawing SA572-S4 and be mounted in the torso assembly in traxial configuration at the T4 location as shown drawing 210-0000. The chest accelerometers are not required for dummy calibration testing but are required for FMVSS 208 low risk deployment testing. (572.146(e))
- D. TEST FIXTURE – The neck pendulum and thorax probe accelerometers shall have the dimensions and characteristics of drawing SA572-S4.

¹ Excluding the chest deflection potentiometer

10.2 OTHER TRANSDUCERS (S572.146)

The following transducers are required only when needed for specific test programs as directed by the COTR.

- A. The neck force-moment transducer shall have the dimensions, response characteristics, and sensitive axis locations specified in drawing SA 572-S19 and be mounted at the upper neck transducer location as shown in drawing 210-0000. A lower neck transducer as specified in drawing SA 572-S19 is allowed to be mounted as optional instrumentation in place of part No. ATD6204, as shown in drawing 210-0000.
- B. The shoulder force transducers shall have the dimensions and response characteristics specified in drawing SA 572-S21 and be allowed to be mounted as optional instrumentation in place of part No. 210-3800 in the torso assembly as shown in drawing 210-0000.
- C. The thorax optional accelerometers shall have the dimensions, response characteristics, and sensitive mass locations specified in drawing SA 572-S4 and may be mounted at T1, and T12, and in uniaxial configuration on the sternum at the midpoint level of ribs No. 1 and No. 3 and on the spine coinciding with the midpoint level of No. 3 rib, as shown in drawing 210-0000.
- D. The chest deflection potentiometer shall have the dimensions and response characteristics specified in drawing SA-572-S50 and be mounted in the torso assembly as shown drawing 210-0000.
- E. The lumbar spine force/moment transducer may be mounted in the torso assembly as shown in drawing 210-0000 in place of part No. 210-4150. If used, the transducer shall have the dimensions and response characteristics specified in drawing SA-572-S20.
- F. The pubic force transducer may be mounted in the torso assembly as shown in drawing 210-0000 in place of part No. 921-0022-036. If used, the transducer shall have the dimensions and response characteristics specified in drawing SA-572-S18.
- G. The acetabulum force transducers may be mounted in the torso assembly as shown in drawing 210-0000 in place of part No. 210-4522. If used, the transducer shall have the dimensions and response characteristics specified in drawing SA-572-S22.
- H. The anterior-superior iliac spine transducers may be mounted in the torso assembly as shown in drawing 210-0000 in place of part No. 210-4540-1, -2. If used, the transducers shall have the dimensions and response characteristics specified in drawing SA-572-S17.

- I. The pelvis accelerometers may be mounted in the pelvis in triaxial configuration as shown in drawing 210-0000. If used, the accelerometers shall have the dimensions and response characteristics specified in drawing SA-572-S4.

10.2 TRANSDUCER TEST CONDITIONS

- A. TRANSDUCER MOUNTS – The mountings for sensing devices shall have no resonance frequency less than 3 times the frequency range of the applicable channel class. (572.146(n))
- B. TRANSDUCER SIGN CONVENTION - The sign convention for outputs of transducers mounted within the dummy that measure head and chest accelerations, chest deflection and neck loads are located in Figure 3 and Table 1. For other transducers see SAE J1733DEC94. (572.146(m))
- C. TRANSDUCER OUTPUTS and FILTERING - The outputs of acceleration and force-sensing devices installed in the dummy and in the test apparatus specified by this part are recorded with individual data channels. Each data channel will be comprised of a sensor, signal conditioner, data acquisition device, and all interconnecting cables, and must conform to the requirements of SAE Recommended Practice J211/1 MAR95, "Instrumentation for Impact Test," with channel classes as follows: (572.146(l))

(1) Head acceleration	Class 1000	(572.146(l)(1))
(2) Neck force	Class 1000	(572.146(l)(2)(i))
(3) Neck pendulum acceleration	Class 180	(572.146(l)(2)(iii))
(4) Neck moment	Class 600	(572.146(l)(2)(ii))
(5) Neck potentiometer	Class 60	(572.146(l)(2)(iv))
(6) Thorax spine acceleration	Class 180	(572.146(l)(3)(ii))
(7) Thorax pendulum acceleration	Class 180	(572.146(l)(3)(ii))
(8) Sternum deflection	Class 600	(572.146(l)(3)(iii))
(9) Lumbar torso flexion	Class 60	(572.146(l)(4)(iii))

All filter classes should be of the "phaseless" type to be compatible with the "time" dependent test parameters.

10.3 THORAX IMPACTOR PROBE (572.146(a))

- A. The test probe for thoracic impacts shall be of rigid metallic construction, concentric in shape and symmetric about its longitudinal axis.
- B. It shall have a mass of 1.70 ± 0.02 kg (3.75 ± 0.05 lb). 1/3 of the weight of the suspension cables and their attachments to the impact probe must be

included in the calculation of mass, and such components may not exceed 5 percent of the total weight of the test probe.

- C. It shall have a minimum mass moment of inertia of $164 \text{ kg}\cdot\text{cm}^2$ ($0.145 \text{ lb}\cdot\text{in}\cdot\text{sec}^2$) in yaw and pitch about the center of gravity of the probe.
- D. The impacting end of the probe is perpendicular to and concentric with the longitudinal axis. It must have a flat, continuous, and non-deformable face with a diameter of $50.8 \pm 0.25 \text{ mm}$ ($2.00 \pm 0.01 \text{ in}$) and an edge radius of $7.6/12.7 \text{ mm}$ ($0.3/0.5 \text{ in}$).
- E. The impactor is a cylinder with a diameter of 53.3 mm (2.1 in) and it is at least 25.4 mm (1.0 in) long.
- F. The probe's end opposite to the impact face must have provisions for mounting of an accelerometer with its sensitive axis collinear with the longitudinal axis of the probe.
- G. The impact probe shall have a free air resonant frequency of not less than 1000 Hz in the direction of the longitudinal direction of the impactor.
- H. Attachments to the impactor, including suspension hardware and impact vanes, shall be designed to prevent contact with the dummy during the test.

SIGN CONVENTIONS FOR PART 572 TEST DUMMIES

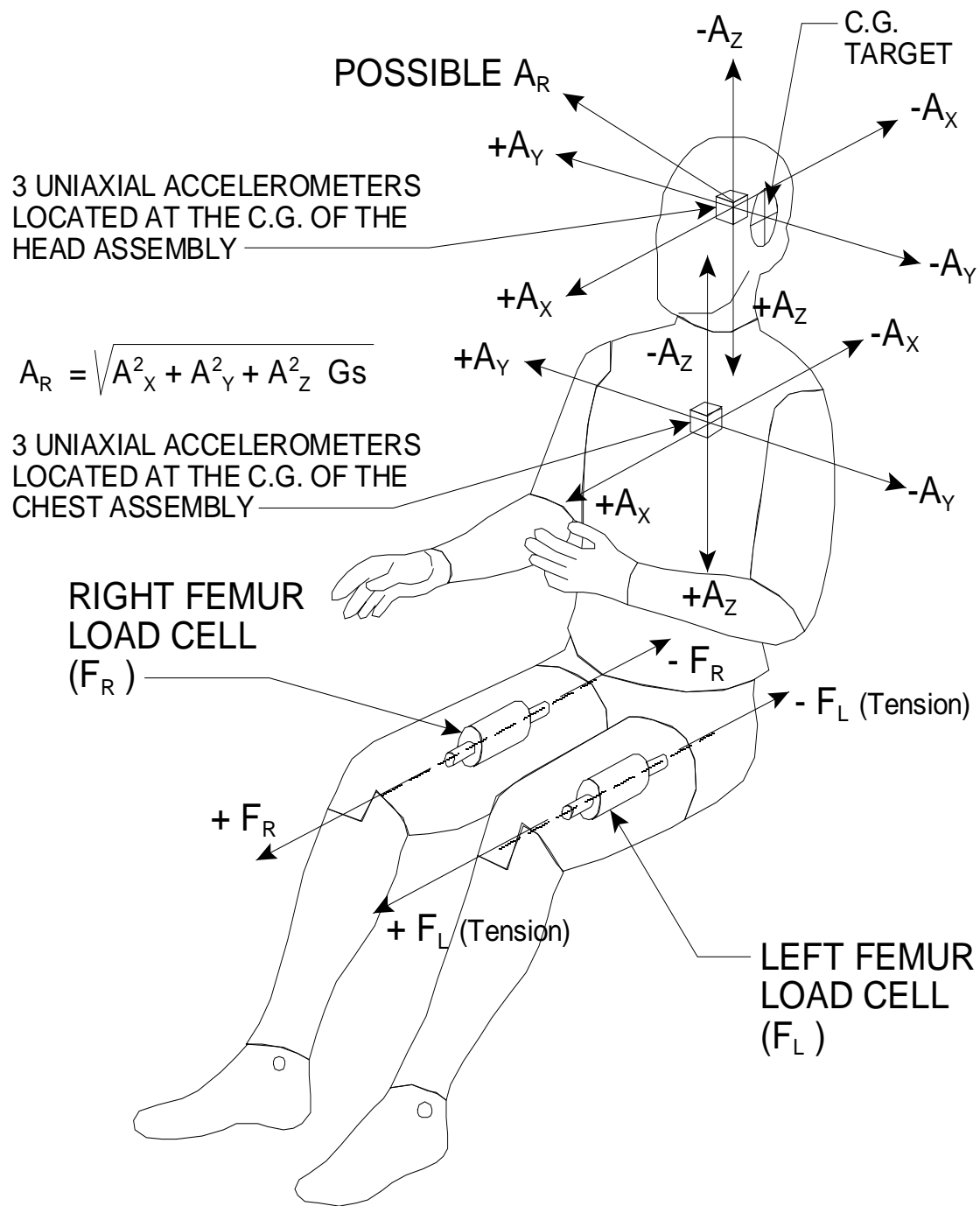

$$A_R = \sqrt{A_X^2 + A_Y^2 + A_Z^2} \text{ Gs}$$

FIGURE 3

TABLE 2. SIGN CONVENTION FOR HYBRID III TRANSDUCER OUTPUTS

BODY SEGMENT — MEASURED FORCE	POSITIVE OUTPUT DIRECTION
NECK FX SHEAR FY SHEAR FZ AXIAL MX MOMENT (ROLL) MY MOMENT (PITCH) MZ MOMENT (YAW)	HEAD REARWARD OR CHEST FORWARD HEAD LEFTWARD, CHEST RIGHTWARD HEAD UPWARD, CHEST DOWNWARD LEFT EAR TOWARD LEFT SHOULDER CHIN TOWARD STERNUM CHIN TOWARD LEFT SHOULDER
FEMUR FX SHEAR FY SHEAR FZ AXIAL MX MOMENT (ROLL) MY MOMENT (PITCH) MZ MOMENT (YAW)	KNEE UPWARD, UPPER FEMUR DOWNWARD KNEE RIGHTWARD, UPPER FEMUR LEFTWARD KNEE FORWARD (TENSION), PELVIS REARWARD KNEE LEFTWARD, HOLD UPPER FEMUR IN PLACE KNEE UPWARD, HOLD UPPER FEMUR IN PLACE KNEE ROTATED CCW WHEN FACING FRONT OF DUMMY
KNEE CLEVIS - FZ AXIAL	TIBIA DOWNWARD (TENSION), FEMUR UPWARD
UPPER TIBIA MX MOMENT MY MOMENT	ANKLE LEFTWARD, HOLD KNEE IN PLACE ANKLE FORWARD, BOTTOM OF KNEE CLEVIS REARWARD
LOWER TIBIA FX SHEAR FY SHEAR FZ AXIAL MX MOMENT MY MOMENT	ANKLE FORWARD, KNEE REARWARD ANKLE RIGHTWARD, KNEE LEFTWARD ANKLE DOWNWARD (TENSION), KNEE UPWARD ANKLE LEFTWARD, HOLD KNEE IN PLACE ANKLE FORWARD, BOTTOM OF KNEE CLEVIS REARWARD
CHEST DISPLACEMENT	CHEST COMPRESSED - NEGATIVE
KNEE SHEAR DISPLACEMENT	PUSH ON FRONT OF TIBIA - NEGATIVE

NOTE: DIRECTIONS ARE DEFINED IN RELATION TO A SEATED DUMMY

10.4 GENERAL TEST CONDITIONS

- A. Surfaces of dummy components are not painted unless otherwise specified. (572.146(q))
- B. Dummy performance tests of the same component, segment, assembly, or fully assembled dummy are separated in time by a period of not less than 30 minutes unless otherwise specified. (572.146(p))
- C. Except for neck assembly and thorax assembly testing, the dummy performance tests are conducted at any temperature from 18.9°C (66°F) to 25.6°C (78°F) and at any relative humidity from 10% to 70% after exposure of the dummy to these conditions for a period of not less than 4 hours. For the neck assembly and thorax assembly, the temperature range is 20.6°C (69°F) to 22.2°C (72°F)
- D. Dummy limb joints are set at 1g, barely restraining the weight of the limb when it is extended horizontally. The force required to move a limb segment does not exceed 2g throughout the range of limb motion. (572.146(o))

11. CALIBRATION TEST EXECUTION

When conducting calibration tests, complete the data sheets in section 14.

11.1 HEAD CALIBRATION (572.142)

A. Head Assembly

The head assembly for this test consists of the head (drawing 210-1000), adapter plate (drawing ATD 6259), accelerometer mounting block (drawing SA 572-S80), structural replacement of ½ mass of the neck load transducer (drawing TE-107-001), head mounting washer (drawing ATD 6262), one ½-20×1" flat head cap screw (FHCS) (drawing 9000150), and 3 accelerometers (drawing SA-572-S4).

B. Requirements

When the head assembly is dropped from a height of 376.0±1.0 mm (14.8±0.04 in), the peak resultant acceleration at the location of the accelerometers at the head CG shall be 250 - 280 g. The resultant acceleration versus time history curve shall be unimodal, and the oscillations occurring after the main pulse shall be less than 10 percent of the peak resultant acceleration. The lateral acceleration shall not exceed ±15g (zero to peak).

C. Procedure

(1) Soak the head assembly in a controlled environment at any temperature between 18.9 and 25.6 °C (66 and 78 °F) and at any relative humidity between 10 and 70 percent for at least four hours prior to a test.

(2) Prior to the test, clean the impact surface of the head skin and the steel impact plate surface with isopropyl alcohol, trichlorethane, or an equivalent. Both impact surfaces must be clean and dry for testing.

(3) Suspend the head assembly with its midsagittal plane in vertical orientation as shown in Figure P1 of this subpart. The lowest point on the forehead is 376.0 ± 1.0 mm (14.76 ± 0.04 in) from the steel impact surface. The 3.3 mm (0.13 in) diameter holes, located on either side of the dummy's head in transverse alignment with the CG, shall be used to ensure that the head transverse plane is level with respect to the impact surface.

(4) Drop the head assembly from the specified height by a means that ensures a smooth, instant release onto a rigidly supported flat horizontal steel plate which is 50.8 mm (2 in) thick and 610 mm (24 in) square. The impact surface shall be clean, dry and have a finish of not less than 203.2×10^{-6} mm (8 micro inches) (RMS) and not more than 2032.0×10^{-6} mm (80 micro inches) (RMS).

(5) Allow at least 2 hours between successive tests on the same head.

11.2 NECK CALIBRATION (572.143)

A. The Neck and Headform Assembly

The neck and headform assembly for the purposes of this test, as shown in Figures 9 and 10, consists of the neck molded assembly (drawing 210-2015), neck cable (drawing 210-2040), nylon shoulder bushing (drawing 9001373), upper mount plate insert (drawing 910420-048), bib simulator (drawing TE-208-050), urethane washer (drawing 210-2050), neck mounting plate (drawing TE-250-021), two jam nuts (drawing 9001336), load-moment transducer (drawing SA 572-S19), and headform (drawing TE-208-000).

B. Requirements

(1) Flexion

(i) Plane D, referenced in Figure 9, shall rotate in the direction of preimpact flight with respect to the pendulum's longitudinal centerline between 70 degrees and 82 degrees. Within this specified rotation

corridor, the peak moment about the occipital condyle may not be less than 42 N-m and not more than 53 N-m.

(ii) The positive moment shall decay for the first time to 10 N-m between 60 ms and 80 ms after time zero.

(iii) The moment and rotation data channels are defined to be zero when the longitudinal centerline of the neck and pendulum are parallel.

(2) Extension

(i) Plane D referenced in Figure 10 shall rotate in the direction of preimpact flight with respect to the pendulum's longitudinal centerline between 83 degrees and 93 degrees. Within this specified rotation corridor, the peak moment about the occipital condyle may be not more than -43.7 N-m and not less than -53.3 N-m.

(ii) The negative moment shall decay for the first time to -10 N-m between 60 and 80 ms after time zero.

(iii) The moment and rotation data channels are defined to be zero when the longitudinal centerline of the neck and pendulum are parallel.

C. Procedure

(1) Soak the neck assembly in a controlled environment at any temperature between 20.6 and 22.2 °C (69 and 72 F) and a relative humidity between 10 and 70 percent for at least four hours prior to a test.

(2) Torque the jam nut (drawing 9001336) on the neck cable (drawing 210-2040) between 0.2 N-m and 0.3 N-m.

(3) Mount the neck-headform assembly, defined in paragraph (a) of this section, on the pendulum so the midsagittal plane of the headform is vertical and coincides with the plane of motion of the pendulum as shown in Figure P2 of this subpart for flexion and Figure P3 of this subpart for extension tests.

(4) Release the pendulum and allow it to fall freely to achieve an impact velocity of 5.50 ± 0.10 m/s (18.05 ± 0.40 ft/s) for flexion and 3.65 ± 0.1 m/s (11.98 ± 0.40 ft/s) for extension tests, measured by an accelerometer mounted on the pendulum as shown in Figure 8 at time zero.

(i) The test shall be conducted without inducing any torsion twisting of the neck.

(ii) Stop the pendulum from the initial velocity with an acceleration vs. time pulse which meets the velocity change as specified in

Table 3. Integrate the pendulum acceleration data channel to obtain the velocity vs. time curve as indicated in Table 3.

(iii) Time-zero is defined as the time of initial contact between the pendulum striker plate and the honeycomb material. The pendulum data channel shall be zero at this time.

TABLE 3. NECK-HEADFORM ASSEMBLY PENDULUM PULSE

Time	Flexion		Time	Extension	
ms	m/s	ft/s	ms	m/s	ft/s
10	2.0 – 2.7	6.6 – 8.9	6	1.0 – 1.4	3.3 – 4.6
15	3.0 – 4.0	9.8 – 13.1	10	1.9 – 2.5	6.2 – 8.2
20	4.0 – 5.1	13.1 – 16.7	14	2.8 - 3.5	9.2 – 11.5

11.3 THORAX CALIBRATION (572.144)

A. The Thorax Assembly

The thorax assembly consists of the upper part of the torso assembly shown in drawing 210-3000.

B. Requirements

When the anterior surface of the thorax of a completely assembled dummy is impacted by a test probe at 6.0 ± 0.1 m/s (19.7 ± 0.4 ft/s):

(1) Maximum sternum displacement (compression) relative to the spine, must not be less than 32mm (1.3 in) and not more than 38mm (1.5 in); the peak force shall be 680 - 810 N. The peak force after 12.5 mm of sternum compression but before reaching the minimum required 32.0 mm sternum compression shall not exceed 910 N. The force is calculated by the product of the impactor mass and its deceleration.

(2) The internal hysteresis of the ribcage in each impact shall be 65 - 85 percent. Hysteresis is calculated by determining the ratio of the area between the loading and unloading portions of the force deflection curve to the area under the loading portion of the curve.

C. Procedure

(1) Clothe the test dummy in cotton-polyester-based tight-fitting shirt with long sleeves and ankle-length pants whose combined weight is not more than 0.25 kg (0.55 lbs). (572.144(c)(1))

(2) Soak the dummy in a controlled environment at any temperature between 20.6 and 22.2 °C (69 and 72 °F) and at any relative humidity between 10 and 70 percent for at least four hours prior to a test.

(3) Seat and orient the dummy on a seating surface without back support as shown in Figure 11, with the lower limbs extended horizontally and forward, the upper arms parallel to the torso and the lower arms extended horizontally and forward, parallel to the midsagittal plane, the midsagittal plane being vertical within ± 1 degree and the ribs level in the anterior-posterior and lateral directions within ± 0.5 degrees.

(4) Establish the impact point at the chest midsagittal plane so that the impact point of the longitudinal centerline of the probe coincides with the dummy's mid-sagittal plane and is centered on the center of No. 2 rib within ± 2.5 mm (0.1 in.) and 0.5 degrees of a horizontal plane.

(5) Impact the thorax with the test probe so that at the moment of contact the probe's longitudinal center line is within 2 degrees of a horizontal line in the dummy's midsagittal plane.

(6) Guide the test probe during impact so that there is no significant lateral, vertical or rotational movement.

(7) No suspension hardware, suspension cables, or any other attachments to the probe, including the velocity vane, shall make contact with the dummy during the test.

11.4 TORSO CALIBRATION (S572.145)

A. The Test Assembly

The dummy shall be fully assembled.

B. Requirements

The test objective is to determine the resistance of the lumbar spine and abdomen of a fully assembled dummy to flexion articulation between upper and lower halves of the torso assembly.

(1) When the upper half of the torso assembly of a seated dummy is subjected to a force continuously applied at the occipital condyle level through the rigidly attached adaptor bracket, the lumbar spine-abdomen assembly shall flex by an amount that permits the upper half of the torso, as measured at the posterior surface of the torso reference plane shown in Figure 13, to translate in angular motion in the midsagittal plane 45 ± 0.5 degrees relative to the vertical transverse

plane, at which time the pulling force applied must be 130 N (28.8 lbf) - 180 N (41.2 lbf)

(2) Upon removal of the force, the upper torso assembly returns to within 10 degrees of its initial position.

A. Procedure.

(1) Soak the dummy in a controlled environment at any temperature between 18.9° and 25.6 °C (66 and 78 °F) and at any relative humidity between 10 and 70 percent for at least 4 hours prior to a test.

(2) Assemble the complete dummy (with or without the lower legs) and seat it on a rigid flat-surface table, as shown in Figure 13 of this subpart.

(i) Unzip the torso jacket and remove the four 1/4 -20×3/4 " bolts which attach the lumbar load transducer or its structural replacement to the pelvis weldment as shown in Figure 13.

(ii) Position the matching end of the rigid pelvis attachment fixture around the lumbar spine and align it over the four bolt holes.

(iii) Secure the fixture to the dummy with the four 1/4 -20×3/4 " bolts and attach the fixture to the table. Tighten the mountings so that the pelvis-lumbar joining surface is horizontal within ±1 deg and the buttocks and upper legs of the seated dummy are in contact with the test surface.

(iv) Attach the loading adapter bracket to the upper part of the torso as shown in Figure 13 and zip up the torso jacket.

(v) Point the upper arms vertically downward and the lower arms forward.

(3) (i) Flex the thorax forward three times from vertical until the torso reference plane reaches 30 ±2 degrees from vertical. The torso reference plane, as shown in figure P5 of this subpart, is defined by the transverse plane tangent to the posterior surface of the upper backplate of the spine box weldment (drawing 210-8020).

(ii) Remove all externally applied flexion forces and support the upper torso half in a vertical orientation for 30 minutes to prevent it from drooping.

(4) Remove the external support and after two minutes measure the initial orientation angle of the upper torso reference plane of the seated,

unsupported dummy as shown in Figure 13. The initial orientation of the torso reference plane may not exceed 15 degrees.

(5) Attach the pull cable at the point of load application on the adaptor bracket while maintaining the initial torso orientation. Apply a pulling force in the midsagittal plane, as shown in Figure 13, at any upper torso flexion rate between 0.5 and 1.5 degrees per second, until the torso reference plane reaches 45 ± 0.5 degrees of flexion relative to the vertical transverse plane.

(6) Continue to apply a force sufficient to maintain 45 ± 0.5 degrees of flexion for 10 seconds, and record the highest applied force during the 10-second period.

(7) Release all force at the loading adaptor bracket as rapidly as possible and measure the return angle with respect to the initial angle reference plane described in step (4), 3 to 4 minutes after the release.

12. POST TEST REQUIREMENTS

The contractor shall verify all instrumentation and check data sheets and photographs. Make sure data is recorded in all data blocks on every performance calibration test data sheet.

13. REPORTS

13.1 APPARENT NONCONFORMANCE

During the posttest calibration verification, any indication of apparent nonconformance to the requirements of Regulation P572 shall be communicated by telephone to the COTR within 24 hours with written notification mailed within 48 hours (Saturdays and Sundays excluded). Written notification shall be submitted with a copy of the particular test data sheet(s) and preliminary data plot(s).

In the event of an apparent nonconformance, a posttest calibration check of some critically sensitive test equipment and instrumentation may be required for verification of accuracy. The necessity for the calibration shall be at the COTR's discretion and shall be performed without additional costs to the OVSC.

13.2 FINAL PERFORMANCE CALIBRATION REPORTS

A report containing the pre-test calibration and posttest calibration verification data for each Part 572, Subpart P dummy used in the test shall be submitted with the compliance final test report if requested by the COTR.

Contractors are required to PROOF READ all Final Test Reports before submittal to the COTR. The OVSC will not act as a report quality control office for contractors. Reports containing a significant number of errors will be returned to the contractor for correction, and a "hold" will be placed on invoice payment for the particular test.

13.2.1 REQUIREMENTS

Performance calibration report Table of Contents shall include the following:

- A. Section 1 — Purpose of Calibration Test
- B. Section 2 — Calibration Data Summary
- C. Section 3 — Test Data
- D. Section 4 — Test Equipment List and Calibration Information
- E. Section 5 — Photographs (if applicable)

The test data for each dummy will be presented in separate sections. Each section shall contain a title page, test results summary and the test data. The title page shall include the dummy's serial number and the manufacturer's name. It will also indicate whether the calibration data is pre or posttest. The test results sheets will provide a summary of each test and describe any damage, failures and/or corrective action taken. The test data shall include the pass/fail data sheets, the time histories for each data channel used to determine the pass or fail status, and instrumentation calibration data sheets.

13.2.2 REPORT COVER FORMAT

The information required on the cover follows:

- A. Final Report Title And Subtitle such as

3-YEAR-OLD DUMMY CALIBRATION
IN SUPPORT OF
FMVSS 213 CHILD RESTRAINT SYSTEM DYNAMIC TESTS

- B. DOT symbol, placed between items B and C



- C. Contractor's Name and Address such as

ABC TESTING LABORATORIES, INC.
405 Main Street
Detroit, Michigan 48070

- D. Date of Final Performance Calibration Report completion

- E. The sponsoring agency's name and address as follows

U. S. DEPARTMENT OF TRANSPORTATION
National Highway Traffic Safety Administration
Enforcement
Office of Vehicle Safety Compliance
Mail Code: NVS-220, W43-481
1200 New Jersey Avenue, SE
Washington, DC 20590

14. DATA SHEETS

DATA SHEET 1 DUMMY DAMAGE CHECKLIST

Dummy Serial Number _____ Test Date _____

Technician _____

This check sheet is completed as part of the posttest calibration verification.

Perform general cleaning.

Dummy Item	Inspect for	Comments	Damaged	OK
Outer skin	Gashes, rips, cracks			
Head	Ballast secure			
	General appearance			
Neck	Broken or cracked rubber			
	Upper neck bracket firmly attached to the lower neck bracket			
	Looseness at the condyle joint			
	Nodding blocks cracked or out of position			
Spine	Broken or cracks in rubber.			
Ribs	Broken or bent ribs			
	Broken or bent rib supports			
	Damping material separated or cracked			
	Rubber bumpers in place			
Chest Displacement Assembly	Bent shaft			
	Slider arm riding in track			
Transducer leads	Torn cables			

Dummy Item	Inspect for	Comments	Damaged	OK
Accelerometer Mountings	Head mounting secure			
	Chest mounting secure			
Knees	Skin condition			
	Insert (do not remove)			
	Casting			
Limbs	Normal movement and adjustment			
Knee Sliders	Wires intact			
	Rubber returned to "at rest" position			
Pelvis	Broken			
Other				

If upon visual examination, damage is apparent in any of these areas, the appropriate engineer or engineering technician is to be consulted for a decision on repair or replacement of parts.

Repair or Replacement approved by:

Signature

Date

Describe the repair or replacement of parts:

Checked by

Signature

Date

DATA SHEET 2
EXTERNAL MEASUREMENTS
(See the PADI, pages 65-68)

Dummy Serial Number _____ Test Date _____

Technician _____

Pretest calibration

Posttest calibration verification

1. Seat the dummy on a flat, rigid, smooth, clean, dry, horizontal surface as shown in Figure 5 and 6. The seating surface is at least 406 mm (16 in) wide and 221 mm (8 11/16 in) in depth with a vertical section at least 406 mm (16 in) wide and 610 mm (24 in) high attached to the rear of the seating fixture. The dummy's midsagittal plane is vertical and centered on the test surface.
2. Secure the dummy to the test fixture so that the upper torso and buttocks are against the rear surface.
3. Position the dummy's H-point so it is 39.4 ± 5.1 mm (1.55 ± 0.2 in) above the horizontal seating surface and 62.0 ± 5.1 mm (2.44 ± 0.2 in) forward of the rear vertical surface of the fixture.
4. Extend the dummy's neck so that the base of the skull is level both fore-and-aft and side-to-side, within 0.5 degrees. The rearmost surface of the head should be 53.3 ± 5.1 mm (2.1 ± 0.2 in) from the vertical surface of the test fixture. A strap or bungee cord may be placed around the forehead of the dummy to stabilize the head in this position.
5. Position the upper and lower legs parallel to the midsagittal plane so the centerline between the knee pivot and the ankle pivot is parallel to the rear vertical surface of the fixture.
6. Position the feet parallel to the dummy's midsagittal plane with the bottoms horizontal and parallel to the seating surface.
7. Position the upper arms downward vertically so the centerline between the shoulders and elbow pivots is parallel to the rear vertical surface of the fixture.
8. Position the lower arms horizontally so the centerline of the lower arm-hand is parallel to the seat surface.
9. Record the dimensions listed in following table, except for dimension Q, X, Y and Z (reference figure 4).
10. Mark the locations AA, and BB, and record the dimensions Y, Z, as specified in the following table and figure 4. Measure and record dimensions Q and X.

Signature

Date

EXTERNAL DIMENSIONS

HYBRID III, PART 572, SUBPART O EXTERNAL DIMENSIONS				
DIMENSION	DESCRIPTION	DETAILS	ASSEMBLY DIMENSION (mm)	ACTUAL MEASUREMENT
A	TOTAL SITTING HEIGHT	Seat surface to highest point on top of the head.	538.5-553.7	
B	SHOULDER PIVOT HEIGHT	Centerline of shoulder pivot bolt to the seat surface.	307.4-322.6	
C	H-POINT HEIGHT	Reference	34.3-44.5	
D	H-POINT LOCATION FROM BACKLINE	Reference	56.9-67.1	
E	SHOULDER PIVOT FROM BACKLINE	Center of the shoulder pivot bolt to the fixture's rear vertical surface.	60.9-71.1	
F	THIGH CLEARANCE	Fixture's seat surface to highest point on the upper leg segment	81.0-91.2	
G	BACK OF ELBOW TO WRIST PIVOT	Back of the elbow flesh to the finger tip, in line with the elbow and wrist centerlines	247.4-262.6	
H	HEAD BACK TO BACKLINE	Rearmost surface of the head to the fixture's rear vertical surface (Reference)	48.2-58.4	
I	SHOULDER TO- ELBOW LENGTH	Measure from the highest point on top of the shoulder to the lowest part of the flesh on the elbow in line with the shoulder and elbow pivot bolts.	185.4-200.6	
J	ELBOW REST HEIGHT	Measure from the flesh below the elbow pivot bolt to the seat surface.	133.6-148.8	
K	BUTTOCK TO KNEE LENGTH	The forward most part of the knee flesh to the fixture's rear vertical surface, in line with the knee and hip pivots.	284.8-300	
L	POPLITEAL HEIGHT	Seat surface to the horizontal plane of the bottom of the feet.	218.5-233.7	
M	KNEE PIVOT HEIGHT	Centerline of knee pivot bolt to the horizontal plane of the bottom of the feet.	241.6-256.8	
N	BUTTOCK POPLITEAL LENGTH	The most forward portion of the crevice between the upper and lower legs behind the knee to the fixture's rear vertical surface.	218.0-233.2	

HYBRID III, SUBPART P EXTERNAL DIMENSIONS, continued				
DIMENSION	DESCRIPTION	DETAILS	ASSEMBLY DIMENSION (mm)	ACTUAL MEASUREMENT
O	CHEST DEPTH WITH JACKET	Measured 254.0 ± 5.1 mm above seat surface	138.5-153.7	
P	FOOT LENGTH	Tip of toe to rear of heel	137.6-147.8	
Q	STATURE	Lay the dummy out on a flat surface with the rear surfaces of the head, upper torso, buttocks and heels touching the surface and with the bottom of the feet perpendicular to that surface. Measure the distance from the bottom of the feet to the top of the head.	932.2-957.6	N/A
R	BUTTOCK TO KNEE PIVOT LENGTH	Knee pivot bolt to the fixture's rear vertical surface.	251.4-261.6	
S	HEAD BREADTH	Distance across the widest of the head at its widest point	128.3-143.5	
T	HEAD DEPTH	Distance from the forward most surface of the head to the rearmost surface of the head, in line with the midsgittal plane.	167.4-182.6	
U	HIP BREADTH	Distance across the width of the hip at the widest point of the jacket	200.7-215.9	
V	SHOULDER BREADTH	Distance between the outside edges of the shoulder flesh, in line with the shoulder pivot bolts	236.5-251.7	
W	FOOT BREADTH	The widest part of the foot	53.6-63.8	
X	HEAD CIRCUMFERENCE	At the largest location	500.4-515.6	
Y	CHEST CIRCUMFERENCE WITH JACKET	Distance around chest at reference location AA, with jacket on.	527.1-552.5	
Z	WAIST CIRCUMFERENCE	Distance around chest at reference location BB, with jacket on.	527.1-552.5	
AA	REFERENCE LOCATION FOR DIMENSION Y	Reference: 254.0 ± 5.1 MM above the seat surface	248.9-259.1	
BB	REFERENCE LOCATION FOR DIMENSION Z	Reference: 165.1 ± 5.1 MM above seat surface	160.0-170.2	

EXTERNAL DIMENSION MEASUREMENT DESIGNATIONS

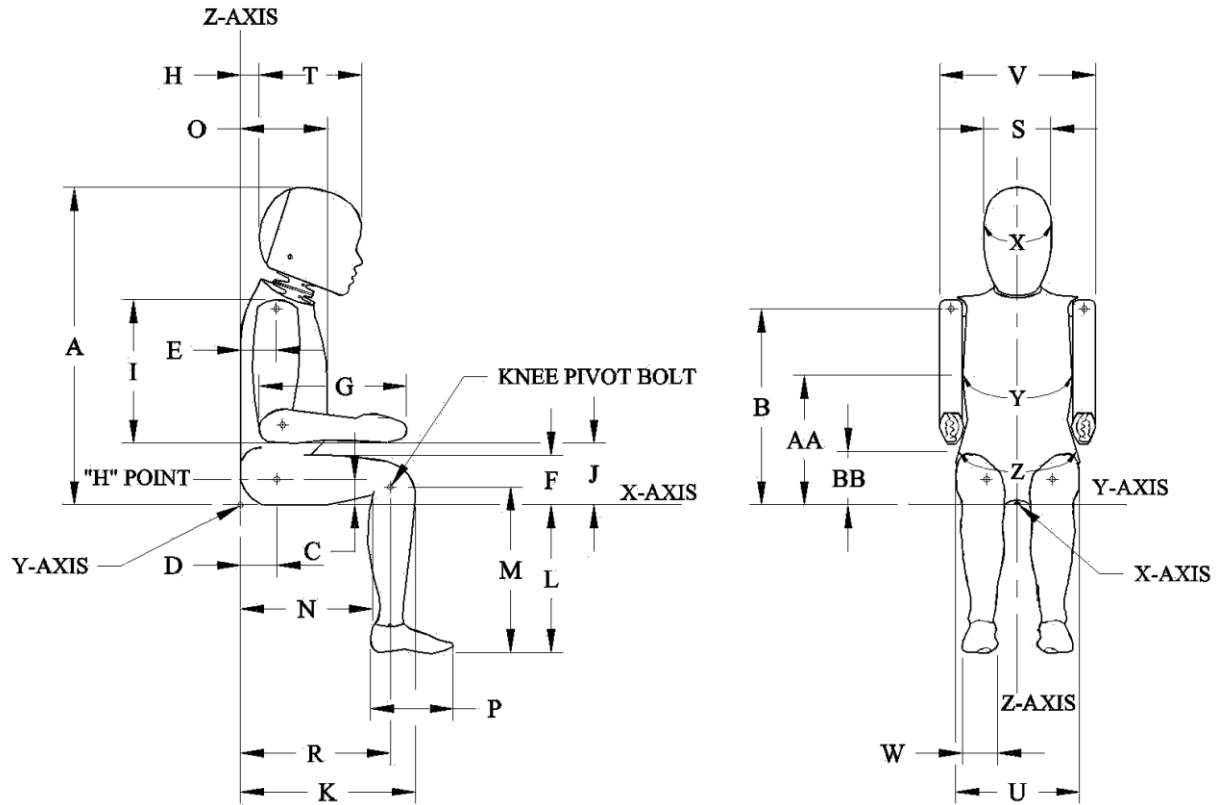

FIGURE 4

EXTERNAL DIMENSIONS TEST SETUP – FRONT VIEW

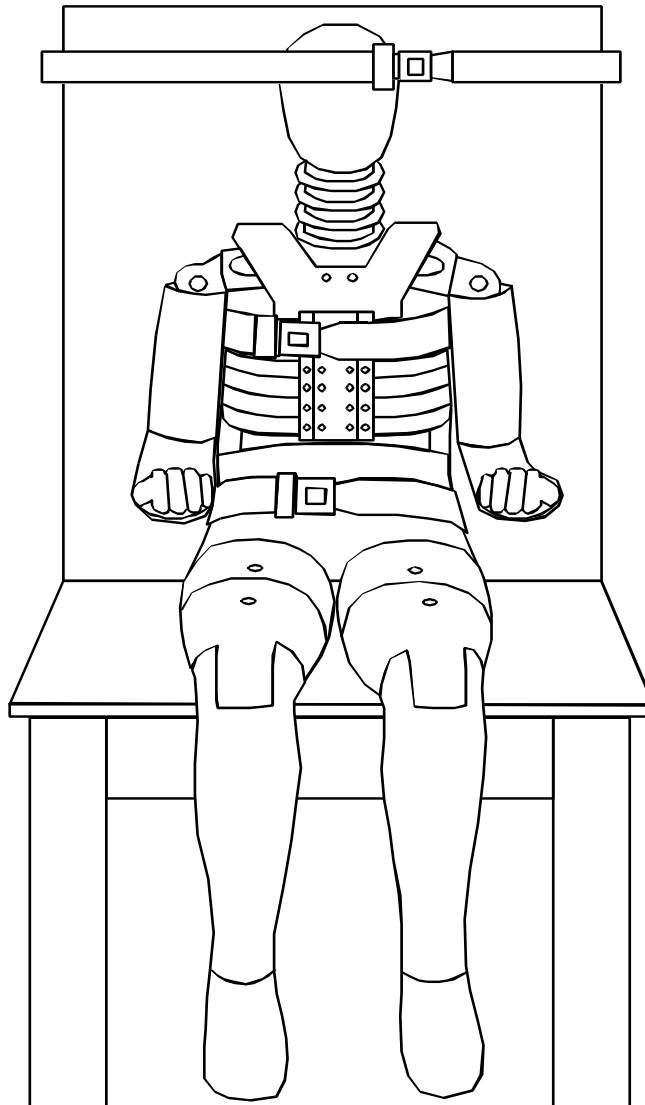

FIGURE 5

EXTERNAL DIMENSIONS TEST SETUP – SIDE VIEW

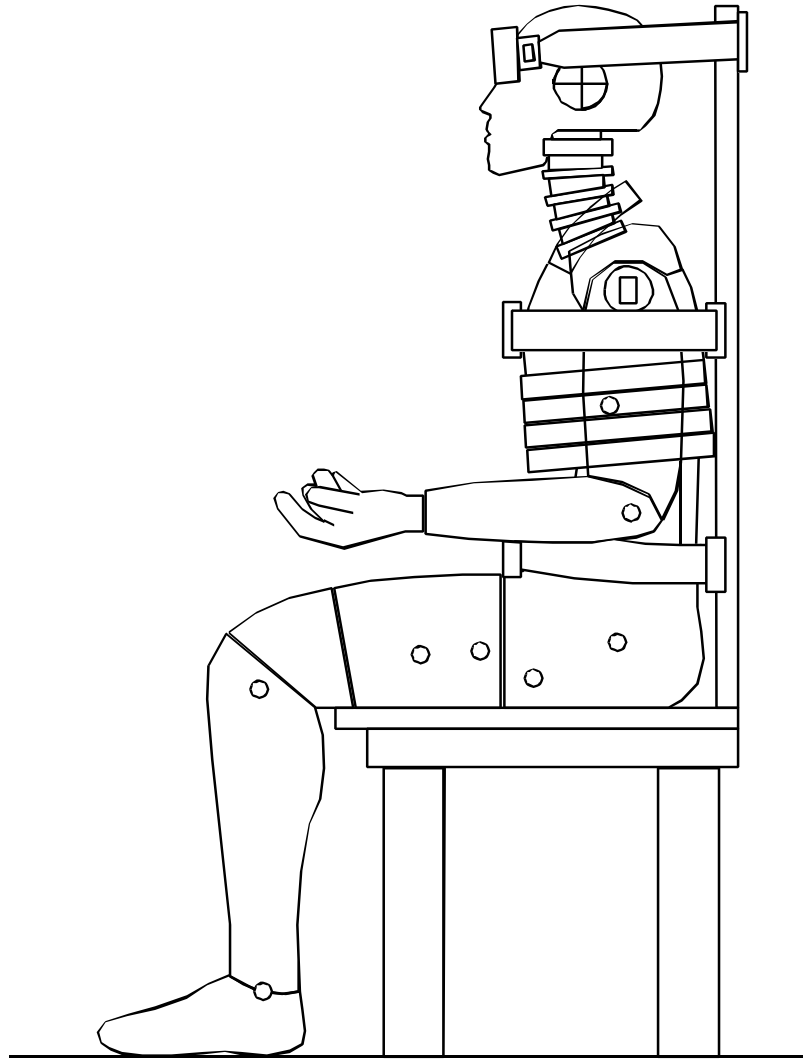

FIGURE 6

DATA SHEET 3
HEAD DROP TEST (572.142)

Dummy Serial Number _____ Test Date _____

Technician _____

- Pretest calibration
- Post test calibration verification

Test attempt no. _____ (when successive head drops are necessary)

- 1. It has been at least 2 hours since the last head drop. (572.142(c)(5))
 N/A, ONLY one head drop performed
- 2. The head assembly consists of the head (210-1000), adaptor plate (ATD 6259), accelerometer mounting block (SA572-S80) structural replacement of ½ mass of the neck load transducer (TE-107-001), head mounting washer (ATD 6262) one ½-20x1" flat head cap screw (9000150), and three (3) accelerometers (SA572-S4). (572.142(a))
- 4. Accelerometers and their respective mounts are smooth and clean.
- 5. The head accelerometer mounting plate screws (10-32 x 5/8 SHCS) are torqued to 7.68 Nm.
- 6. The data acquisition system, including transducers, conforms to the requirements of SAE Recommended Practice J211/1 MAR95. (572.146(l))
- 7. The head assembly soaked at a temperature between 18.9°C (66°F) and 25.6°C (78°F) and at a relative humidity from 10% to 70% for a period of at least four (4) hours prior to a test. (572.142(c)(1))
Record the maximum temperature _____
Record the minimum temperature _____
Record the maximum humidity _____
Record the minimum humidity _____
- 8. Visually inspect the head skin for cracks, cuts, abrasions, etc. Repair or replace the head skin if the damaged area is more than superficial. Note: If the damage resulted from the low risk deployment test in which the dummy was an occupant, the damaged area is to be documented with photography and the post test calibration verification testing completed before any replacement or repairs are made.
Record findings and actions: _____

- 9. Clean the impact surface of the skin and the impact surface of the fixture with isopropyl alcohol, trichloroethane or equivalent prior to the test. (572.142(c)(2))

__10. Suspend and orient the head assembly as shown in Figure 7D. The lowest point on the forehead is 376.0 ± 1.0 mm (14.8 ± 0.04 inch) from the impact surface. (572.142(c)(3))

Record the actual distance _____

NOTE: The masses of the suspension device and the accelerometer cables are to be kept as lightweight as possible to minimize their effect on the test results.

__11. The 3.3 mm (0.13 inch) diameter holes located on either side of the dummy's head are equidistant within 2 mm from the impact surface. (572.142(c)(3))

Record the right side distance _____

Record the left side distance _____

__12. The impact surface is clean and dry and has a micro finish in the range of 203.2×10^{-6} mm (8 micro inches) to 2032.0×10^{-6} mm (80 micro inches) (RMS). (572.142(c)(4))

Record actual micro finish _____

__14. The impact surface is a flat horizontal steel plate 50.8 mm (2 inches) thick and 610 mm (24 inches) square. (572.142(c)(4))

Record thickness _____

Record width _____

Record length _____

__15. Drop the head assembly from a height of 376.0 ± 1.0 mm (14.8 ± 0.04 inches) by a means that ensures a smooth, instant release onto the impact surface. (572.142(b) & 572.142(c)(4))

__16. Complete the following table. (572.142(b)):

Parameter	Specification	Result
Peak resultant acceleration	$250 \text{ g} \leq x \leq 280 \text{ g}$	
Resultant versus time history curve	Unimodal	
Oscillations after the main pulse	Less than 10% of the peak resultant acceleration	
Lateral acceleration	y-axis acceleration $\leq 15 \text{ g}$	

__17. Plots of the x, y, z, and resultant acceleration data follow this sheet.

Signature

Date

HEAD DROP TEST SET-UP SPECIFICATIONS

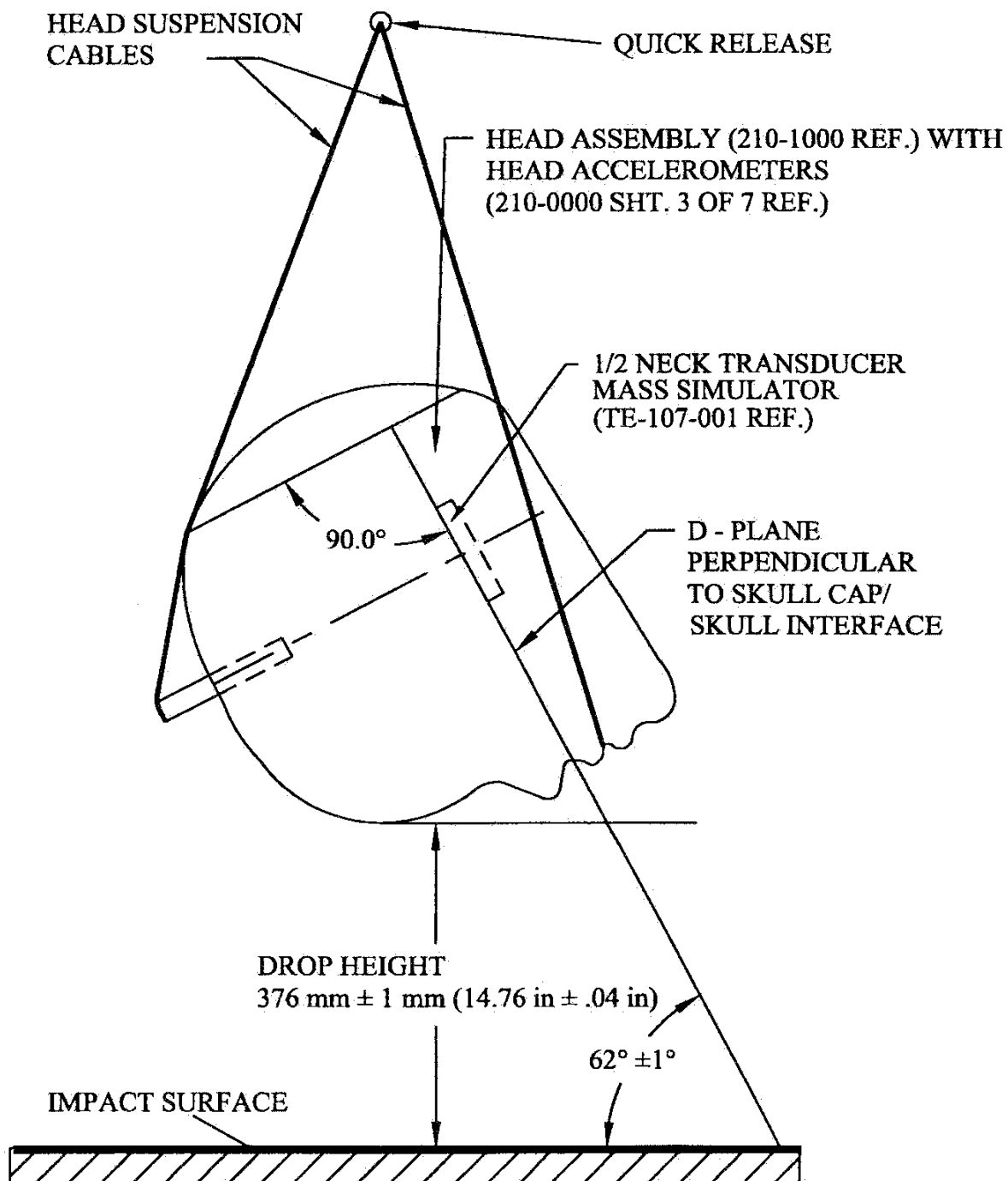

FIGURE 7

DATA SHEET 4
NECK FLEXION TEST (572.143)

Dummy Serial Number _____ Test Date _____

Technician _____

- Pretest calibration
- Post test calibration verification

Test attempt no. _____ (when successive flexion tests are necessary)

- 1. It has been at least 30 minutes since the last neck test. (572.146(p))
 N/A, this is the first neck test performed
- 2. The components required for the neck tests include the neck molding assembly (210-2015), neck cable (210-2040), nylon shoulder bushing (9001373), upper mount plate insert (910420-048), bib simulator (TE-208-050), urethane washer (210-2050), neck mounting plate (TE-250-021), two jam nuts (9001336), load moment transducer (SA572-S19) and headform (TE-208-000). (572.143(a))
- 3. The assembly soaked at a temperature between 20.6°C (69°F) and 22.2°C (72°F) and at a relative humidity from 10% to 70% for a period of at least four (4) hours prior to a test. (572.143(c)(1))
Record the maximum temperature _____
Record the minimum temperature _____
Record the maximum humidity _____
Record the minimum humidity _____
- 4. Visually inspect neck assembly for cracks, cuts and separation of the rubber from the metal segments. Note: If the damage resulted from the low risk deployment test, the damaged area is to be documented with photography and the post test calibration verification testing completed before any replacement or repairs are made.
Record findings and actions: _____

- 6. Torque the jam nut (9001336) on the neck cable (210-2040) between 0.2 Nm and 0.3 Nm. (572.143(c)(2))
- 7. The data acquisition system, including transducers, conforms to the requirements of SAE Recommended Practice J211/1 MAR95. (572.146(l))
- 8. The test fixture pendulum conforms to the specifications in Figure 8D.
- 9. The head-neck assembly is mounted on the pendulum so the midsagittal plane of the headform is vertical and coincides with the plane of motion of the pendulum as shown in Figure 9 for the flexion test. (572.143(c)(3))
- 10. Install the transducers or other devices for measuring the "D" plane rotation with respect to the pendulum longitudinal centerline. Note: Plane "D" is the top

horizontal surface of the neck load cell. These measurement devices should be designed to minimize their influence upon the performance of the head-neck assembly.

- __11. Plane D is perpendicular ± 1 degree to the centerline of the pendulum.
- __12. Set the instrumentation so that the moment and rotation are defined to be zero when the longitudinal centerline of the neck and pendulum are parallel. (572.143(b)(1)(iii))
- __13. Release the pendulum and allow it to fall freely from a height to achieve an impact speed of 5.4 m/s to 5.6 m/s as measured at the center of the pendulum accelerometer. (572.143(c)(4))
- __14. Complete the following table:

Neck Flexion Test Results (572.143(b)(1) & (572.143(c)(4)(ii))

Parameter	Specification	Result
Pendulum impact speed	5.4 m/s \leq speed \leq 5.6 m/s	
Pendulum ΔV with respect to impact speed	@ 10ms	2.0 m/s $\leq \Delta V \leq$ 2.7 m/s
	@ 15 ms	3.0 m/s $\leq \Delta V \leq$ 4.0 m/s
	@ 20ms	4.0 m/s $\leq \Delta V \leq$ 5.1 m/s
Plane D Rotation	Peak moment* 42 Nm \leq moment \leq 53 Nm during the following rotation range 70 $^{\circ}$ \leq angle \leq 82 $^{\circ}$	___ Nm @ ___ degrees
Positive Moment Decay** (Flexion)	Time to decay to 10 Nm 60 ms \leq time \leq 80ms	

*The moment is a direct reading from the load cell

**Time zero is defined as the time of initial contact between the pendulum striker plate and the honeycomb material. (572.143(c)(4)(iii))

- __15. Plots of pendulum acceleration, pendulum velocity, neck y-axis moment, and neck rotation about the y-axis follow this sheet.

Signature

Date

DATA SHEET 5
NECK EXTENSION TEST (572.143)

Dummy Serial Number _____ Test Date _____

Technician _____

- Pretest calibration
- Post test calibration verification

Test attempt no. _____ (when successive extension tests are necessary)

- 1. It has been at least 30 minutes since the last neck test. (572.146(p))
 N/A, this is the first neck test performed
- 2. The components required for the neck tests include the neck molding assembly (210-2015), neck cable (210-2040), nylon shoulder bushing (9001373), upper mount plate insert (910420-048), bib simulator (TE-208-050), urethane washer (210-2050), neck mounting plate (TE-250-021), two jam nuts (9001336), load moment transducer (SA572-S19) and headform (TE-208-000). (572.143(a))
- 3. The assembly soaked at a temperature between 20.6°C (69°F) and 22.2°C (72°F) and at a relative humidity from 10% to 70% for a period of at least four (4) hours prior to a test. (572.143(c)(1))
Record the maximum temperature _____
Record the minimum temperature _____
Record the maximum humidity _____
Record the minimum humidity _____
- 4. Visually inspect neck assembly for cracks, cuts and separation of the rubber from the metal segments. Note: If the damage resulted from the low risk deployment test, the damaged area is to be documented with photography and the post test calibration verification testing completed before any replacement or repairs are made.
Record findings and actions: _____

- 6. Torque the jam nut (9001336) on the neck cable (210-2040) between 0.2 Nm and 0.3 Nm. (572.143(c)(2))
- 7. The data acquisition system, including transducers, conforms to the requirements of SAE Recommended Practice J211/1 MAR95. (572.146(l))
- 8. The test fixture pendulum conforms to the specifications in Figure 8D.
- 9. The head-neck assembly is mounted on the pendulum so the midsagittal plane of the headform is vertical and coincides with the plane of motion of the pendulum as shown in Figure 10 for the extension test. (572.143(c)(3))
- 10. Install the transducers or other devices for measuring the "D" plane rotation with respect to the pendulum longitudinal centerline. Note: Plane "D" is the top

horizontal surface of the neck load cell. These measurement devices should be designed to minimize their influence upon the performance of the head-neck assembly.

- __11. Plane D is perpendicular $\pm 1^\circ$ to the centerline of the pendulum.
- __12. Set the instrumentation so that the moment and rotation are defined to be zero when the longitudinal centerline of the neck and pendulum are parallel. (572.143(b)(2)(iii))
- __13. Release the pendulum and allow it to fall freely from a height to achieve an impact speed of 3.55 m/s to 3.75 m/s as measured at the center of the pendulum accelerometer. (572.143(c)(4))
- __14. Complete the following table:

Neck Extension Test Results (572.143(b)(2) & (572.143(c)(4)(ii))

Parameter		Specification	Result
Pendulum impact speed		$3.55 \text{ m/s} \leq \text{speed} \leq 3.75 \text{ m/s}$	
Pendulum ΔV with respect to impact speed	@ 6 ms	$1.0 \text{ m/s} \leq \Delta V \leq 1.4 \text{ m/s}$	
	@ 10 ms	$1.9 \text{ m/s} \leq \Delta V \leq 2.5 \text{ m/s}$	
	@ 14 ms	$2.8 \text{ m/s} \leq \Delta V \leq 3.5 \text{ m/s}$	
Plane D Rotation		Peak moment* $-53.3 \text{ Nm} \leq \text{moment} \leq -43.7 \text{ Nm}$ during the following rotation range $83 \leq \text{angle} \leq 93$	___ Nm @ ___ degrees
Negative Moment Decay** (Extension)		Time to decay to -10 Nm $60 \text{ ms} \leq \text{time} \leq 80 \text{ ms}$	

*The moment is a direct reading from the load cell

**Time zero is defined as the time of initial contact between the pendulum striker plate and the honeycomb material. (572.143(c)(4)(iii))

- __15. Plots of pendulum acceleration, pendulum velocity, neck y-axis moment, and neck rotation about the y-axis follow this sheet.

Signature

Date

PENDULUM SPECIFICATIONS

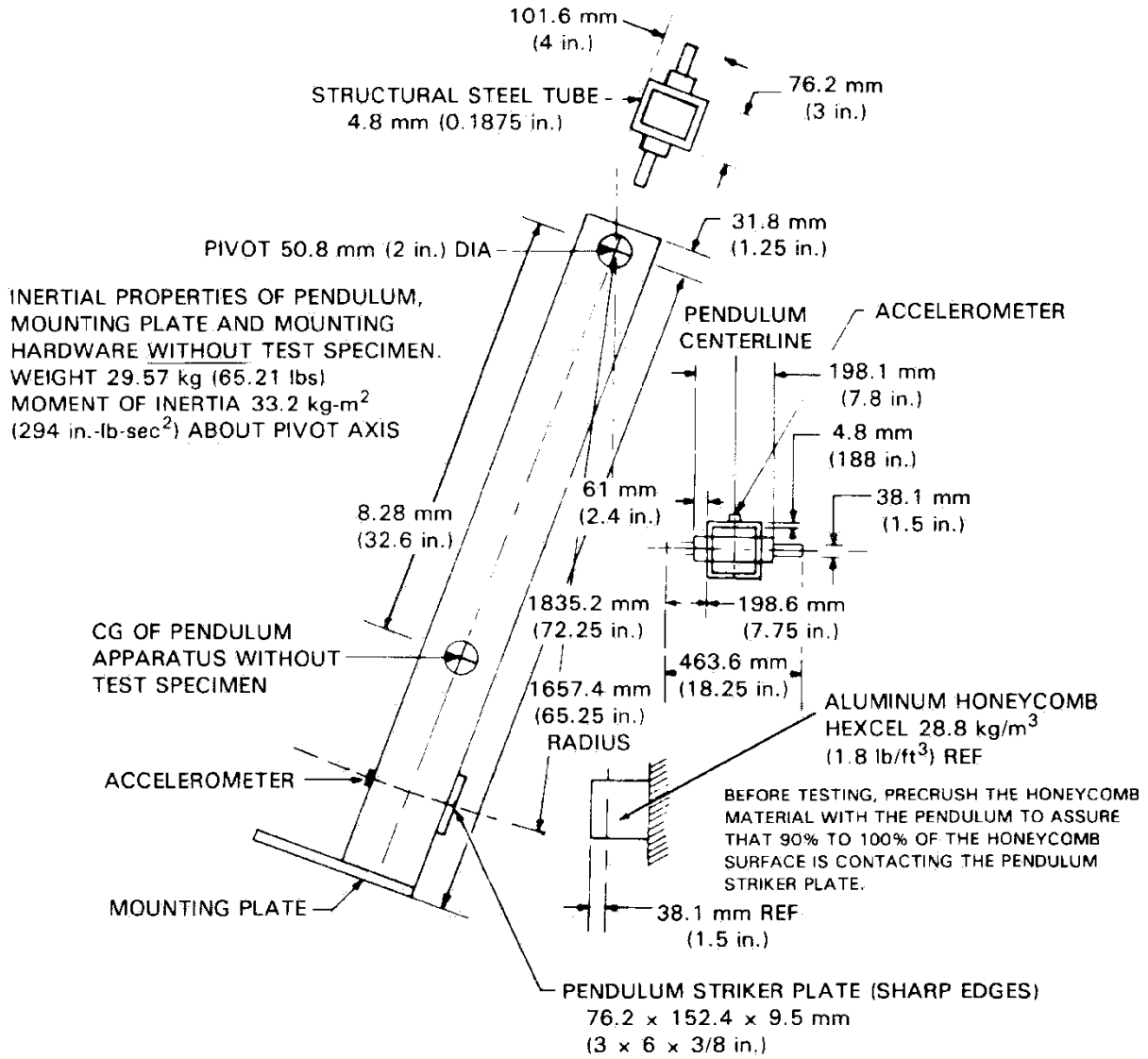
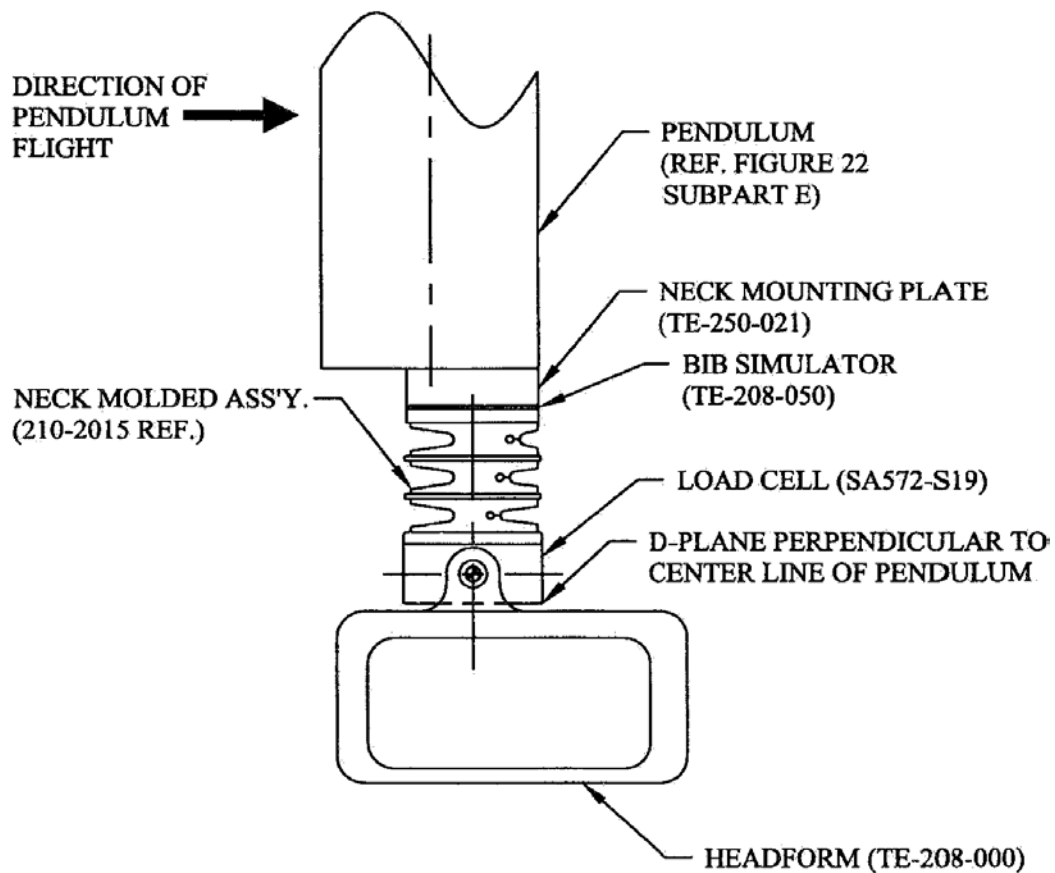

FIGURE 8

NECK FLEXION TEST SET-UP SPECIFICATIONS



NOTE: MOUNT NECK AT LEADING EDGE OF PENDULUM TO AVOID INTERFERENCE WITH HEADFORM MOTION. PENDULUM SHOWN IN VERTICAL ORIENTATION.

FIGURE 9

NECK EXTENSION TEST SET-UP SPECIFICATIONS

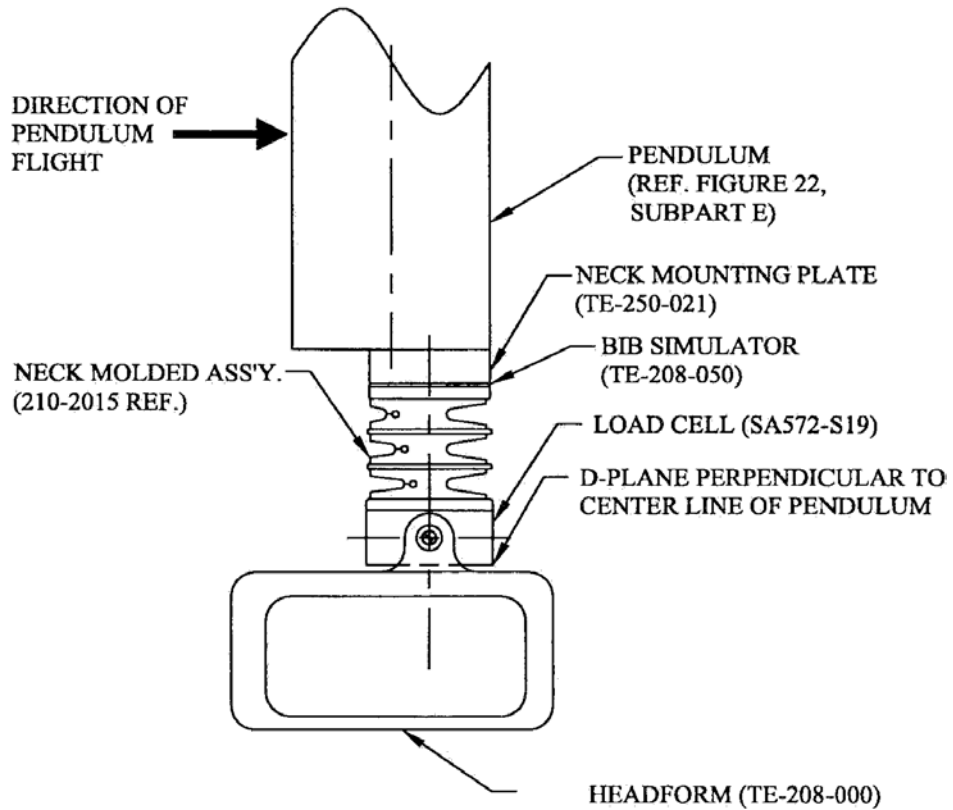

NOTE: MOUNT NECK AT LEADING EDGE OF PENDULUM TO AVOID INTERFERENCE WITH HEADFORM MOTION.
PENDULUM SHOWN IN VERTICAL ORIENTATION.

FIGURE 10

DATA SHEET 6
THORAX IMPACT TEST (572.144)

Dummy Serial Number _____ Test Date _____

Technician _____

- Pretest calibration
- Post test calibration verification

Test attempt no. _____ (when successive thorax impact tests are necessary)

- 1. It has been at least 30 minutes since the last thorax impact test. (572.146(p))
 N/A, ONLY one thorax impact test performed
- 2. The test fixture conforms to the specifications in Figure 11D.
- 3. The complete assembled dummy (210-0000) is used (572.144(b)) and is dressed in cotton-polyester-based tight-fitting long sleeved shirt and ankle length pants. The weight of the shirt and pants shall not exceed 0.25 kg. (572.144(c)(1))
- 4. The dummy assembly soaked at a temperature between 20.6°C (69°F) and 22.2°C (72°F) and at a relative humidity from 10% to 70% for a period of at least four (4) hours prior to this test. (572.144(c)(2))
Record the maximum temperature _____
Record the minimum temperature _____
Record the maximum humidity _____
Record the minimum humidity _____
- 5. Remove the arms.
- 6. Unzip the 3 zippers and fold down the chest jacket. Visually inspect the thorax assembly for cracks, cuts, abrasions, etc. Particular attention should be given to the rib damping material, chest displacement transducer assembly and the rear rib supports. Inspect for rib deformation using the chest depth gage. If any damage is noted repair and/or replace the damaged components unless the damage resulted from the vehicle crash test in which the dummy was an occupant in which case the damage must be documented and post test calibration verification testing completed before any repairs or replacements are made.
 - No damage
 - Damage from crash test, no repairs or replacement because this is a post test calibration verification. Record damage _____

 - The following repairs or replacement was performed. Record _____

- 7. Seat the dummy, without back and arm supports on the test fixture surface as shown in Figure 11D. The surface must be long enough to support the pelvis and outstretched legs. (572.144(c)(3))
- 8. Level the middle rib both longitudinally and laterally $\pm 0.5^\circ$. (572.144(c)(3))

- ___9. The midsagittal plane of the dummy is vertical within $\pm 1^\circ$. (572.144(c)(3))
- ___10. The longitudinal centerline of the test probe is centered within ± 2.5 mm of the midsagittal plane of the dummy and is centered on the center of the No. 2 rib within ± 2.5 mm within $\pm 0.5^\circ$ of a horizontal line in the dummy's midsagittal plane. (572.144(c)(4))
- ___11. Record locations such as the rear surfaces of the thoracic spine and the lower neck bracket reference with respect to the laboratory coordinate system. These reference measurements are necessary to ensure the dummy is in the same position after the chest skin is rolled up and zipped, and the arms installed. The reference locations must be accessible after the chest skin is rolled up and the arms installed. It will be necessary to leave the chest skin zipper unfastened until the references are checked and then fasten it just prior to the test.
- ___12. Install the chest skin and arms, and reposition the dummy using the reference measurements recorded.
- ___13. Place the upper arms parallel to the torso. Place the lower arms horizontal and forward and parallel to the midsagittal plane. (572.144(c)(3))
- ___14. The data acquisition system, including transducers, must conform to the requirements of SAE Recommended Practice J211/1 MAR95 (572.146(l)).
- ___15. Impact the anterior surface of the thorax with the test probe so the longitudinal centerline of the probe is within 2° of a horizontal line in the dummy's midsagittal plane at the moment of impact. (572.144(c)(5)) The velocity of the test probe at the time of impact is between 5.9 m/s and 6.1 m/s. (572.144(b)) The probe is guided so there is no significant lateral, vertical or rotational movement during the impact. (572.144(c)(6)) Neither the suspension hardware, suspension cables, nor other attachments to the probe, including the velocity vane, make contact with the dummy during the test. (572.144(c)(7))
- ___16. Complete the following table:

Thorax Impact Results (572.144(b) and 572.144(b)(1)&(2))

Parameter*	Specification	Result
Test Probe Speed	$5.9 \text{ m/s} \leq \text{speed} \leq 6.1 \text{ m/s}$	
Chest Compression	$32 \text{ mm} \leq \text{compression} \leq 38 \text{ mm}$	
Peak force** between 32 and 38 mm chest compression	$680 \text{ N} \leq \text{peak force} \leq 810 \text{ N}$	
Peak force** between 12.5 and 32.0 mm chest compression	Peak force $\leq 910 \text{ N}$	
Internal Hysteresis***	$65\% \leq \text{hysteresis} \leq 85\%$	

*Time zero is defined as the time of initial contact between the test probe and the chest skin.

**Force = impactor mass x acceleration (572.144(b)(3))

***Area under loading curve minus the area under the unloading curve divided by the area under the loading curve. (Figure 12D)

__17. Plots of chest compression, pendulum acceleration, pendulum force, and force versus deflection follow this sheet.

Signature _____

Date _____

THORAX IMPACT TEST SET-UP SPECIFICATIONS

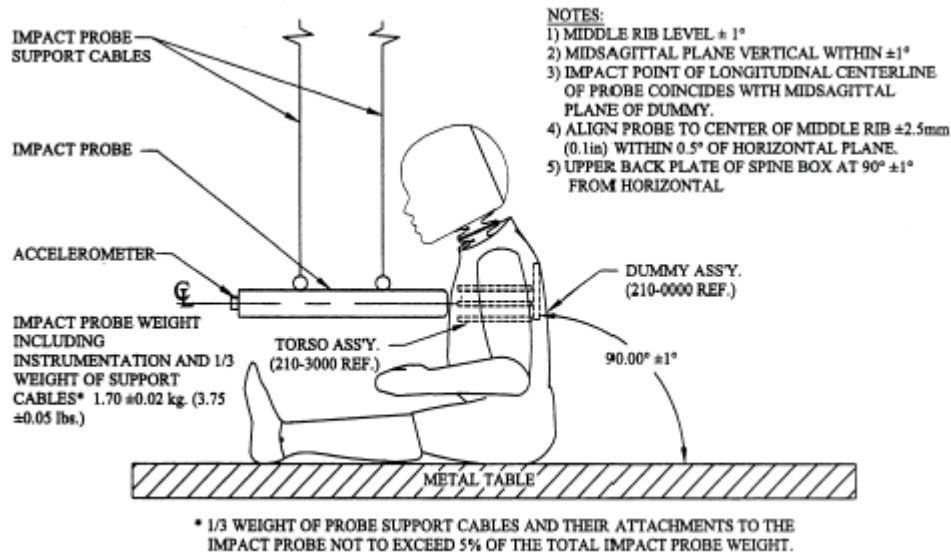

FIGURE 11

Probe specifications:

1. Rigid metallic construction, concentric its longitudinal axis.
2. A mass of 1.7 ± 0.02 kg (3.75 ± 0.05 lb). 1/3 of the weight of the suspension cables and their attachments to the impact probe are included in the calculation of mass, and such components may not exceed 5 percent of the total weight of the test probe.
3. Minimum mass moment of inertia of 164 kg-cm² (0.145 lb-in-sec²) in yaw and pitch about the center of gravity.
4. The impacting end of the probe is perpendicular to and concentric with the longitudinal axis. It has a flat, continuous, and non-deformable face with diameter of 50.8 ± 0.2 mm (2.00 ± 0.01 in) and a maximum edge radius of 7.6-12.7 mm (0.3-0.5 in).
5. The impactor is a cylinder with a diameter of 53.3 mm (2.1 in) and it is at least 25.4 mm (1.0 in) long.
6. The probe's end opposite to the impact face must have provisions for mounting of an accelerometer with its sensitive axis collinear with the longitudinal axis of the probe.
7. The impact probe shall have a free air resonant frequency of not less than 1000 Hz in the direction of the longitudinal direction of the impactor.

PART 572P HYBRID III-3C THORAX CALIBRATION – HYSTERESIS

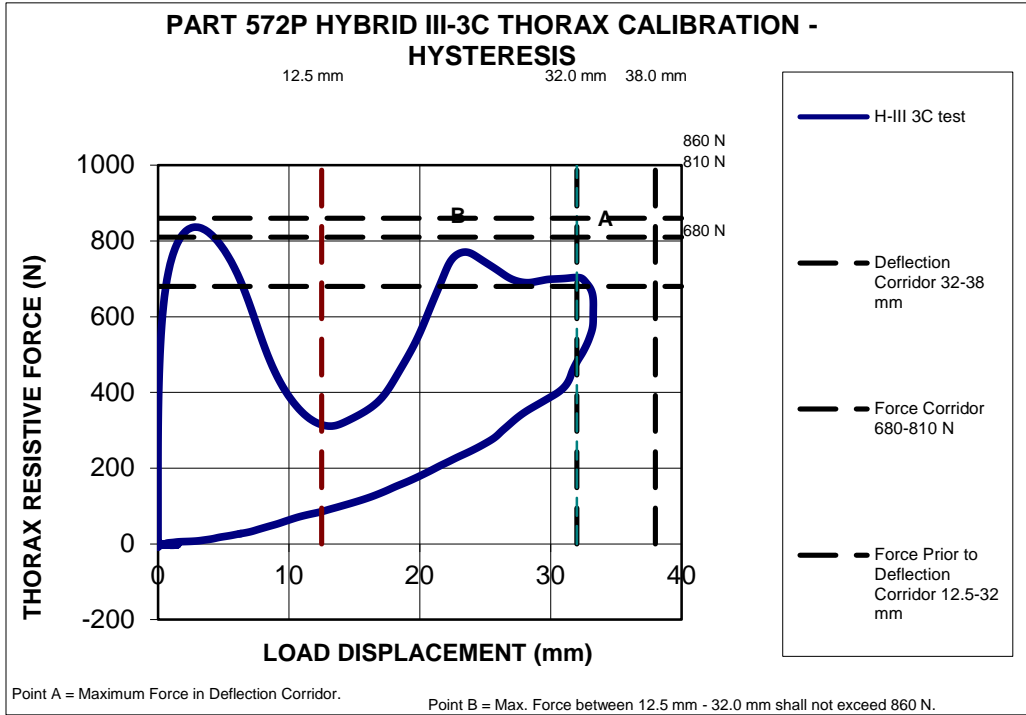

FIGURE 12

DATA SHEET 7
TORSO FLEXION TEST (572.145)

Dummy Serial Number _____ Test Date _____

Technician _____

Pretest calibration
 Post test calibration verification

Test attempt no. _____ (when successive torso flexion tests are necessary)

- 1. It has been at least 30 minutes since the last torso flexion test. (572.146(p))
 N/A, ONLY one thorax impact test performed
- 2. The test fixture conforms to the specifications in Figure 13D.
- 3. The complete assembled dummy (210-0000) is used with or without the lower legs. (572.145(c)(2)).
 with legs below the femurs.
 without legs below the femurs.
- 4. The dummy assembly soaked at a temperature between 18.9°C (66°F) and 25.6°C (78°F) and at a relative humidity from 10% to 70% for a period of at least four (4) hours prior to this test. (572.145(c)(1))
Record the maximum temperature _____
Record the minimum temperature _____
Record the maximum humidity _____
Record the minimum humidity _____
- 5. Unzip the torso jacket and remove the lumbar load transducer or its structural replacement from the dummy. Attach the rigid pelvis attachment fixture to the lumbar spine. (572.145(c)(2)(i)&(ii))
- 5. Secure the fixture to the table so that the pelvis-lumbar joining surface is horizontal within $\pm 1^\circ$ and the buttocks and upper legs of the seated dummy are in contact with the test surface. (572.145(c)(2)(iii))
- 6. Attach the loading adapter bracket to the upper part of the torso as shown in Figure 13 and zip up the torso jacket. (572.145(c)(2)(iv))
- 7. Place the upper arms parallel to the torso and the lower arms extended horizontally and forward, parallel to the midsagittal plane. (572.145(c)(2)(v))
- 8. Flex the dummy forward and back 3 times such that the angle of the torso reference plane moves between 0° and $30^\circ \pm 2^\circ$. The torso reference plane is defined by the transverse plane tangent to the posterior surface of the upper backplate of the spine box weldment (210-8020). (572.145(c)(3)(i))
- 9. Remove all externally applied flexion forces and support the dummy such that the torso reference plane is at or near 0° . Wait at least 30 minutes before continuing. (572.135(c)(3)(ii))
- 10. Remove all external support that was implemented in 9 above and wait 2 minutes. (572.145(c)(4))

- __11. Measure the initial orientation angle of the upper torso reference plane of the seated, unsupported dummy. (572.145(c)(4))
Record reference plane angle (max. allowed 15°)_____
- __12. Attach the pull cable and the load cell while maintaining the initial torso orientation. (572.145(c)(5))
- __13. Apply a tension force in the midsagittal plane to the pull cable at any upper torso deflection rate between 0.5° and 1.5° per second, until the torso reference plane reaches 45° ± 0.5° of flexion relative to the vertical transverse plane. (572.145(c)(5))
- __14. Maintain angle reference plane at 45° ± 0.5° of flexion for 10 seconds and record the highest applied force during this period. (572.145(c)(6))
- __15. As quickly as possible release the force applied to the attachment bracket. (572.145(c)(8))
- __16. 3 to 4 minutes after the release of the force, measure the angle reference plane. (572.145(c)(8))
- __17. Complete the following table:

Torso Flexion Results (572.145(b)(1)&(2), 572.145(c)(4), (572.145(c)(5))

Parameter	Specification	Result
Initial ref. plane angle	Angle ≤ 15°	
Torso rotation rate	0.5°/s ≤ rate ≤ 1.5°/s	
Force at 45° ±0.5°	130 N ≤ force ≤ 180 N	
Final ref. plane angle	Initial ref. plane angle ±10°	

- __18. A plot of the force versus time follows this sheet.

Signature

Date

TORSO FLEXION TEST SET-UP SPECIFICATION

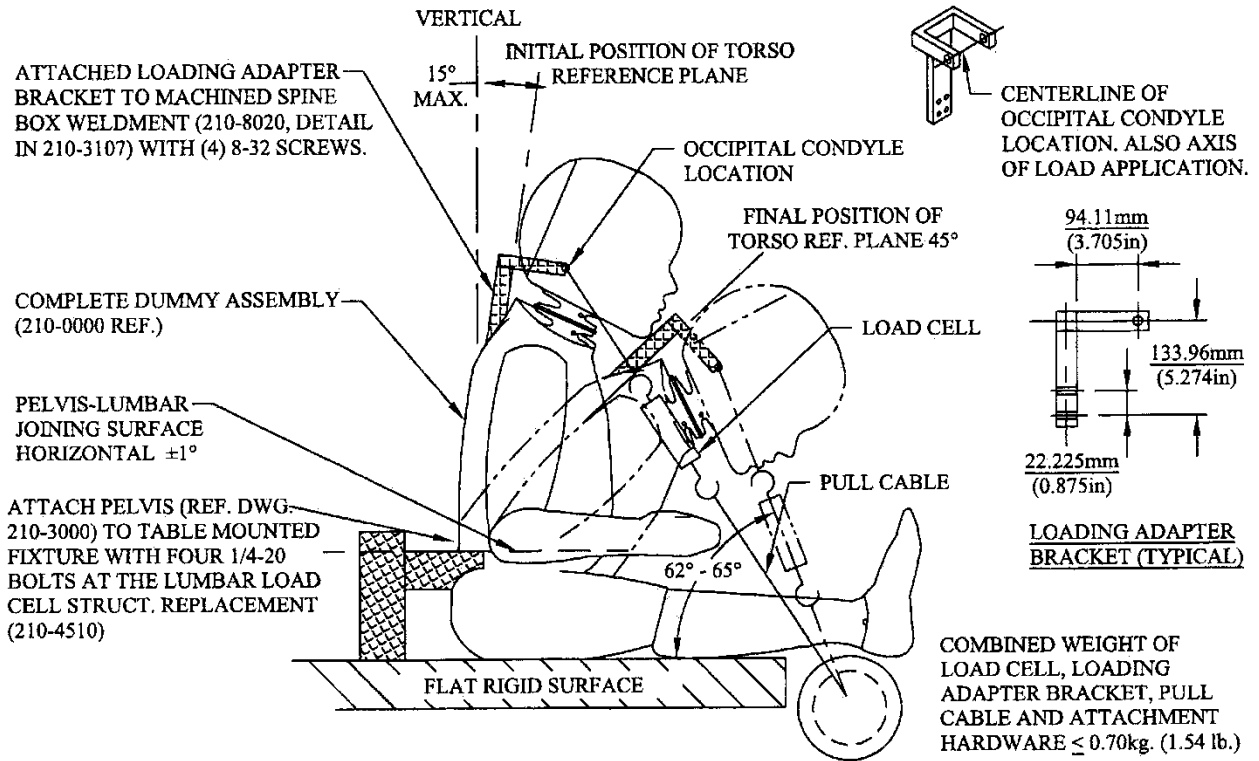

FIGURE 13

DATA SHEET 8
PART 572 INSTRUMENTATION CALIBRATION INFORMATION

I.D. NO.	MANUFACTURER	MODEL NO.	SERIAL NO.	DATE OF LAST CALIBRATION	DATE OF NEXT CALIBRATION
DUMMY INSTRUMENTATION					
HEAD ACCELEROMETERS					
(1) LONGITUDINAL					
(2) LATERAL					
(3) VERTICAL					
NECK TRANSDUCER					
CHEST ACCELEROMETERS					
(1) LONGITUDINAL					
(2) LATERAL					
(3) VERTICAL					
CHEST POTENTIOMETER					
FEMUR LOAD CELLS					
(1) RIGHT FEMUR					
(2) LEFT FEMUR					
LABORATORY INSTRUMENTATION					
NECK PENDULUM ACCELEROMETER					
THORAX PENDULUM ACCELEROMETER					
KNEE PENDULUM ACCELEROMETER					
NECK ROTATION TRANSDUCER 1 (OPTIONAL)					
NECK ROTATION TRANSDUCER 2 (OPTIONAL)					

LABORATORY TECHNICIAN: _____